

Power Quality Analyzer

EM-PQ 2300

Operating Manual

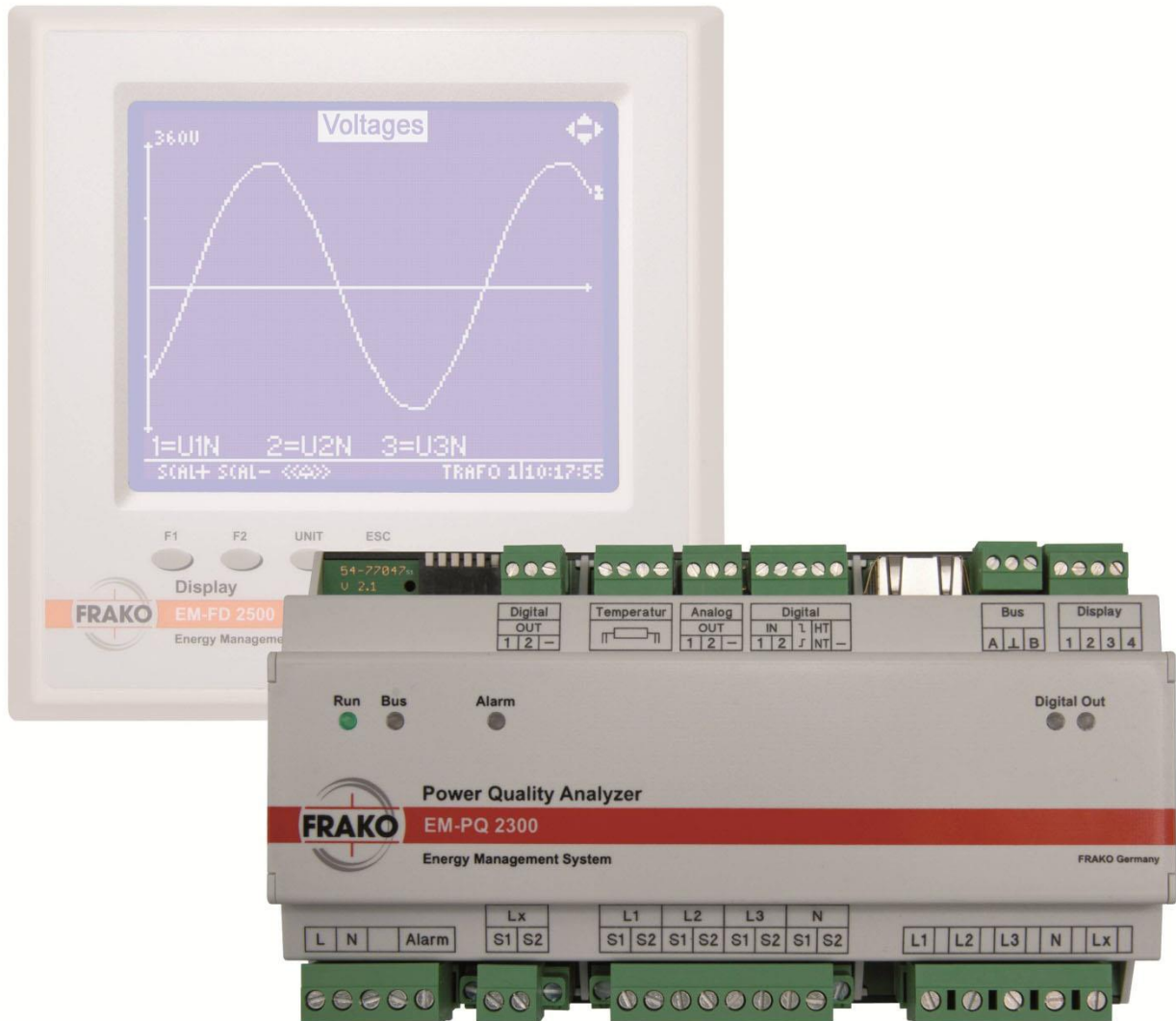

Contents

Figures	4
1. Safety	5
1.1 Objective.....	5
1.1 Safety instructions	5
1.2 Intended use.....	5
1.3 Improper use	6
1.4 Repair	6
1.5 Symbols used	6
2. Technical data	7
3. Instrument description	10
3.1 Connections.....	10
3.2 LEDs	10
4. Mounting the instrument	11
4.1 Suitable location	11
4.2 Installing the instrument.....	11
5. Installation	12
5.1 Electrical connections.....	12
5.1.1 Instrument power supply	15
5.1.2 Measurement connections	15
5.1.2.1 Voltage measurement	15
5.1.2.2 Current measurements.....	16
5.1.3 Ethernet connection.....	18
5.1.4 Connecting to the FRAKO Starkstrombus®, alternatively Modbus.....	18
5.1.5 Display bus	19
5.1.5.1 Requirements for the bus cabling.....	20
5.1.5.2 Cable types.....	20
5.1.5.3 Number of devices on the Display bus.....	21
5.1.5.4 Terminating resistors	21
5.1.6 Digital OUT 1/2	21
5.1.7 Analog OUT 1/2.....	21
5.1.8 Digital IN 1/2, Trigger IN, tariff switching	21
5.1.9 Temperature IN	22
5.1.10 Alarm	22
6. Commissioning (initial start-up)	23
6.1 Safety precautions before start-up	23
6.2 Functional checkout.....	23
6.3 Configuration switches (DIP switches).....	23
6.3.1 Functions of the DIP switches	23
6.3.2 DHCP options.....	24
6.3.3 Fixed network IP address	24
6.3.4 Mode of the RS-485 interface	24
6.4 Terminating resistors on the Display bus	24
6.4.1 Activating the terminating resistor in the EM-FD 2500.....	25
6.4.2 Activating the terminating resistors in other devices	25
6.4.3 Address assignment	25
6.5 Installation of the FRAKO software Device Manager.....	25
6.5.1 IT requirements	25
6.5.2 Installation	26
6.5.3 Configuration of the EM-PQ 2300	26
7. Configuration	26
7.1 Address assignment.....	26
7.1.1 Ethernet.....	26
7.1.1.1 Default values for network setting	26
7.1.1.2 Configuration of the network setting	26
7.1.1.2.1 Setting the IP address on the EM-FD 2500 Display instrument.....	26

7.1.1.2.2	Obtaining the IP address from the DHCP server	27
7.1.1.2.3	Setting the IP address without an EM-FD 2500 Display	27
7.1.2	FRAKO Starkstrombus®	28
7.1.3	Display bus	28
7.1.3.1	Terminating resistors on the Display bus	28
7.2	Outputs	28
7.2.1	Digital OUT 1/2	28
7.2.2	Analog OUT 1/2	28
7.2.3	Alarm relay	28
7.3	Inputs	28
7.3.1	Digital IN 1/2	28
7.3.2	Temperature	29
8.	Operation.....	29
8.1	Via the EM-FD 2500 Display instrument	29
8.1.1	Geräte / Devices page	29
8.1.2	Start menu page	29
8.1.3	Display, Overview page	30
8.1.4	Display, Phase values page	30
8.1.5	Display, THD/VI page	31
8.1.6	Display, Harmonics page.....	31
8.1.7	Display, Graphs page	31
8.1.8	Display, TN-S measurement page	32
8.1.9	Display, Energy meter page	32
8.1.10	Display, Big display page	32
8.1.11	Display, big display page, Current page.....	32
8.1.12	Display, big display page, Voltage page	32
8.1.13	Display, big display page, Total power page.....	33
8.1.14	Display, big display page, TN-S measurement page	33
8.1.15	Display, Active alarms page	33
8.1.16	Configuration, Configuration page.....	33
8.1.17	Configuration, Changing the setting parameters / Password entry.....	33
8.2	Web interface	34
8.2.1	Menu	34
8.2.2	Operation.....	34
8.2.3	Password.....	34
8.3	SNMP	34
9.	Maintenance.....	35
9.1	Cleaning the instrument.....	35
9.2	Battery	35
9.3	Fuse.....	36
10.	Decommissioning and removal, storage and disposal	37
10.1	Decommissioning and removal	37
10.2	Storage	37
10.3	Disposal	38
	Any electronic device that is no longer required must be disposed of in an environmentally sound manner.....	38
11.	General operating notes	38
12.	Troubleshooting	38
13.	Scope of supply.....	39

Figures

Figure 1	Front view of the EM-PQ 2300 with the optional EM-FD 2500 Display	page 1
Figure 2	DIN rail bus connector	page 10
	Manufacturer: Phoenix Contact	
	Order code: HBUS 161,6-16P-1S BK, Article No. 2278555	
Figure 3	Dimensions	page 11
Figure 4	Retracting the retaining clips	page 12
Figure 5	3-phase connection diagram	page 14
Figure 6	Single-phase connection diagram	page 14
Figure 7	FRAKO Starkstrombus	page 18
Figure 8	EM-FD 2500 Display	page 19
Figure 9	Configuration switches (DIP switches)	page 23
Figure 10	Location of the MAC address (typical example)	page 27

1. Safety

1.1 Objective

This operating manual has been prepared for persons who install, connect, commission and operate the EM-PQ 2300 Power Quality Analyzer.

1.1 Safety instructions



DANGER!

The following instructions must be observed to prevent danger to life and limb or damage to equipment and other assets:

- Installation and commissioning of the instrument in industrial plant must be carried out in strict compliance with the standards IEC 61508 and DIN VDE 0801.
- Any other laws, standards, regulations and safety rules (IEC, EN, VDE, etc.) relevant to this product and the protection of persons and assets must be observed. In Germany, it is essential to comply with the Equipment Safety Act (GSG) and the regulations of the German Social Accident Insurance Institutions. In other countries, the equivalent local regulations must be followed.
- Installation, commissioning, modifications and retrofitting may only be carried out by appropriately qualified personnel.
- In Germany, it is essential to comply with the regulations of the Social Accident Insurance Institution covering electrical installations. In other countries, the equivalent local regulations must be followed.
- The instrument contains live components at the AC supply voltage and must therefore not be opened.
- If the instrument is visibly damaged, it must not be installed, connected or commissioned.
- If the instrument does not work after commissioning, it must again be isolated from the power supply.
- Do not expose the instrument to direct sunlight or high temperatures, as these could damage it or shorten its service life.
- Do not install the instrument near to sources of heat such as radiators or other devices that generate or transmit heat.
- Do not expose the instrument to rain, water, dampness or high levels of humidity. Avoid direct contact with water at all cost.
- Failure to observe the safety instructions can result in death, serious injury or severe damage to equipment and other assets.
- The safety of the system in which the EM-PQ 2300 is incorporated is the responsibility of the persons installing and operating the system.
- This operating manual may be changed without notification. Please consult our website www.frako.com for the up-to-date version.

When work is carried out on the instrument terminals and connecting cables, there is a risk of live components being touched inadvertently. The working voltage may present a hazard to health or may even be life-threatening.

Observing the above safety precautions can significantly reduce the risk to life and limb.

- The user must ensure that all operators are familiarized with this operating manual and follow it at all times.
- This operating manual must be read through carefully and completely before the instrument is installed, connected, commissioned and operated. All actions taken must be in accordance with this operating manual.
- The operating manual must be held for future reference.

1.2 Intended use

The EM-PQ 2300 Power Quality Analyzer is intended for the following applications within the scope of the technical data (see page 7):

- Measurement of parameters relevant to network power quality, such as voltage, current, supply voltage fluctuations and sags, harmonics and frequency fluctuations, for all three phases L1, L2 and L3 and in part also for the neutral conductor N and the protective earth PE, within the measurement ranges, see *Section 2, Technical data, page 7*.
- Recording of energy-consuming processes and analysis of peak loads
- Network analyses as per EN 50160
- Measurement of a temperature by means of a Pt100 or PTt1000 probe
- Data acquisition via S0 pulse inputs possible
- Connection of an alarm contact within the permitted electrical rating, see *Section 2, Technical data, page 7*.
- Two values of energy can be output in pulse form (S0 outputs)
- Two analogue outputs (0/4–20 mA or 0–10 V) can be used for any measurement readings
- Connection to the FRAKO Starkstrombus, alternatively to a Modbus network
- Connection to an Ethernet network
- Operation via a FRAKO EM-FD 2500 Display instrument

1.3 Improper use

Any use of the instrument that deviates from its intended use is considered improper and therefore not permitted. If the EM-PQ 2300 is used in a way not specified in this operating manual, the protection supported by the instrument may be adversely affected.

1.4 Repair

Repairs may not be carried out by the customer or user. Should repair work be necessary, the customer or instrument operator must contact the manufacturer:
FRAKO Kondensatoren und Anlagenbau GmbH, Tscheulinstrasse 21A, D-79331 Teningen, Germany.

1.5 Symbols used

Special instructions in this operating manual are marked by symbols.

The corresponding word that expresses the extent of the danger is also printed above the instructions.

In order to avoid accidents, death or injury and damage to assets, these instructions must be complied with at all times.

Warning signs



DANGER!

Indicates an immediate danger that if not avoided can result in death or serious injury.



DANGER!

Indicates an immediate danger of electric shock that if not avoided can result in death or serious injury.

Notes for the correct functioning of the instrument



CAUTION!

These instructions indicate dangers that could result in damage to equipment if the instructions are not followed.

They can also cover aspects of environmental protection.



NOTE!

These instructions, when followed, serve to ensure the correct functioning and fault-free operation of the instrument.

2. Technical data

Instrument power supply

- Supply voltage 90–267 V AC, frequency 45–65 Hz, or 100–360 V DC (absolute limits). Internal slow-blow, surge-proof fuse 2 A, 250 V AC, clearing I²t approx. 92.7 A²s
- Power draw max. 8 W with EM-FD 2500 Display connected, or max. 5 W without EM-FD 2500 Display
- Overcurrent protection External, max. 2 A required

Inputs

- Voltage path measurement inputs 5 × 80 V AC, max. 690 V AC (phase–phase, absolute limits), corresponding to 115–600 V AC networks, electrically interconnected via high resistance, medium voltage measurement via Δ /100 V transformer possible, external 2A fuse required
- Overcurrent protection External, max. 2 A specified
- Current path measurement inputs 5 × x/5 A AC or x/1 A AC (transformer secondary current > 6 mA), electrically isolated from each other, power draw max. 0.5 VA per transformer connection, continuous overload rating up to 6 A AC, max. 10 A AC
- Digital inputs 4 × S0 pulse inputs as per DIN 43864:
Digital IN 1/2, Trigger IN, tariff switching
Common earth connection, in addition electrically connected with the digital outputs, analogue outputs and temperature input
- Temperature input Pt100 or Pt1000 RTD, 4-wire or 2-wire configuration, automatic detector type identification
Measurement range -50 – 200 °C, resolution 1 °C
Earth connection commoned with the digital outputs, digital inputs and analogue outputs
Active from hardware v1.8 and firmware v1.72

Outputs

- Digital outputs 2 × S0 pulse outputs as per DIN 43864, internal resistance 420 Ω, max. permitted voltage 27 V DC
Each output should preferably be routed to a device with a digital input that conforms to the S0 pulse standard.
Common earth connection, in addition electrically connected with the digital inputs, analogue outputs and temperature input
- Analogue outputs 2 × 0/4–20 mA or 0–10 V DC
Each output separately and automatically identifies signal type as current or voltage from the externally connected loads. Signal range 0–20 mA or 4–20 mA configurable with software
Load resistances with current signal: 0 to 300 Ω
Load resistances with voltage signal: 2 to 100 kΩ
Common earth connection, in addition electrically connected with the digital outputs, digital inputs and temperature input
- Alarm contact Volt-free NO contact
Electrical durability AC-11 250 V AC, max. 3 A or DC-13 25 V DC, max. 3 A, mechanical service life = 20×10^6 switching cycles, electrical service life AC-11 at 3 A = 10^5 switching cycles, AC-11 at 0.5 A = 10^6 switching cycles, utilization category AC-x / DC-x as per IEC 60947-4-1

Interfaces

- Ethernet interface 100 Mbit/s, RJ45
- FRAKO Starkstrombus[®], alternatively Modbus, RS-485, surge impedance 120 Ω, as per EN 50170 (PNet), for connecting to the FRAKO Energy Management System.

alternatively text messaging (SMS) via a modem

Alternatively can be configured for Modbus.

Text messaging via PNet modem coupler available as optional extra

- Display bus

CAN bus as per ISO 11898, RS-485, surge impedance 120 Ω, for connecting the EM-FD 2500 Display instrument of the FRAKO Energy Management System

Number of devices on CAN bus: max. 7 EM instruments such as the EM-PQ 2300 or the EM-MC 2200 and one EM-FD 2500 Display or max. 6 devices and two EM-FD 2500 Displays, however no more than one EM-FD 2500 Display per EM-PQ 2300 or EM-MC 2200

Connections

Via pluggable screw terminals

- Power supply L and N:

Conductor cross section max. 2.5 mm², min. 0.2 mm²
Insulation rating: 250 V AC, 80 °C

- Voltage measurement inputs L1, L2, L3, N, Vx:

Conductor cross section max. 2.5 mm², min. 0.2 mm²
Insulation rating: max. measured voltage × 1.1
(Example: 230 V AC × 1.1 = 253 V AC, thus select 250 V AC), 80 °C

- Current measurement inputs L1, L2, L3, N, Vx,
terminals S1 and S2 in each case:

Conductor cross section max. 2.5 mm², min. 0.2 mm²
Insulation rating: 250 V AC, 80 °C

- Alarm:

Conductor cross section max. 2.5 mm², min. 0.2 mm²
Insulation rating: 250 V AC, 80 °C

- Digital OUT 1, 2,-:

Conductor cross section max. 1.4 mm², min. 0.14 mm²
Insulation rating: 50 V DC, 80 °C

- Digital IN 1, 2,-:

Conductor cross section max. 1.4 mm², min. 0.14 mm²
Insulation rating: 50 V DC, 80 °C

- Analog OUT 1, 2,-:

Conductor cross section max. 1.4 mm², min. 0.14 mm²
Insulation rating: 50 V DC, 80 °C

- Temperature IN:

Conductor cross section max. 1.4 mm², min. 0.14 mm²
Insulation rating: 50 V DC, 80 °C

- FRAKO Starkstrombus A,B,⊥:

Conductor cross section max. 1.4 mm², min. 0.14 mm²
Insulation rating: 50 V DC, 80 °C

- Display bus 1, 2, 3, 4:

Conductor cross section max. 1.4 mm², min. 0.14 mm²
Insulation rating: 50 V DC, 80 °C

- Ethernet:

RJ45 plug, Cat 5 as per EIA/TIA-568,100 Mbit/s
Insulation rating: 50 V DC, 80 °C

Note:

0.14 mm² ≅ AWG 26; 0.2 mm² ≅ AWG 25;
1.4 mm² ≅ AWG 17; 2.5 mm² ≅ AWG 14

Design data

- Dimensions

L × W × H: 161.6 mm (9 HP) × 89.7 mm × 62.2 mm casing

L × W × H: 161.6 mm (9 HP) × 93 mm × 62.2 mm incl. connectors

- Mounting

Snaps over DIN TS 35 top hat rail to EN 50022.

- Weight

approx. 500 g

- Ingress protection

Casing IP30, terminals IP20 as per EN 60529,
pollution degree 2 as per EN 61010-1:2011-07

- Electrical design

Casing protection class I as per EN 61140

Working voltage up to max. 690 V AC absolute value at voltage measurement inputs

TNV-1 circuits, some of which interconnected:

Digital OUT 1, 2,-; Digital IN 1,2,-; Analog OUT 1,2,-; FRAKO Starkstrombus A, B, ⊥; Display bus 1, 2,3,4; Ethernet

- Casing design

To DIN 43880. Flammability rating UL 94 V-0 according to casing manufacturer

	Impact resistance IK06 as per EN 61010-1:2011-07, 8.2.2
• Service life	At +25 °C ambient temperature 10 years, at +40 °C ambient temperature 6 years
• EMC	EMC as per EN 61326-1 EN 61000-4-2, electrostatic discharge: air 8 kV and contact 4 kV with horizontal and vertical coupling plane EN 61000-4-3, radiated immunity (EMS) 80 MHz – 1 GHz, horizontal and vertical, level 10 V/m = industrial environment radiation, Class A EN 55022A EMI 30 MHz – 1 GHz = office and residential area, Class B EN 61000-4-6, immunity to conducted disturbances, level 10 V RMS, 150 kHz – 80 MHz EN 61000-4-4, burst immunity, 1 kV capacitive coupling, 2 kV injection into power supply cable and voltage measurement inputs EN 61000-4-5 surge immunity, 2 kV injection into power supply cable and voltage measurement inputs
Ambient conditions	
• Temperature range	-20 °C to +60 °C, noncondensing
• Installation altitude	Maximum height above sea level 2000 m
Measuring system	
• Accuracy	At 25 °C ambient temperature, voltage and current readings $\pm 1\%$, temperature readings ± 2 °C
• Averaging function	L1, L2, L3, L1–L2, L2–L3, L3–L1, N, PE: over 200 ms
• Harmonics measurement	Measured from L1–L3, not from N, PE
• Interharmonics	Measured down to 5 Hz
• Harmonics	Up to the 51st harmonic

3. Instrument description

The EM-PQ 2300 Power Quality Analyzer is a useful addition to the FRAKO range of products. It offers the possibility of carrying out long-term network analyses in compliance with EN 50160 or EN 61000-2-4, monitoring short supply network sags and performing TN-S system measurements. Harmonics up to the 51st are measured. The user can select from several options for recording data, e.g. for analysis of the power demand profile over time.

An outstanding feature is the possibility to acquire measurement data from the neutral conductor N, and even more importantly from the earth conductor PE, in addition to the three phases L1, L2 and L3. Voltage and current can be measured in all conductors.

Measurement readings, graphs, alarms and waveforms can be viewed on the optional EM-FD 2500 Display instrument, which can show data from up to seven EM-PQ 2300 or other suitable instruments of the FRAKO Energy Management System. The devices whose data are to be displayed are selected using the keys on the EM-FD 2500 to navigate a menu.

The EM-PQ 2300 Power Quality Analyzer has a DIN rail mounted casing with plug-in connectors for simple installation and connection to suitable individual instruments of the FRAKO Energy Management System.

Installation can be further simplified with the optional **DIN rail bus connector**, which can be obtained from the manufacturer, **Phoenix Contact**, with the order code **HBUS 161,6-16P-1S BK, Article No. 2278555**. This enables the bus connections of the EM-PQ 2300 Power Quality Analyzer or EM-MC 2200 Maximum Optimizer instruments mounted next to each other on the same DIN rail to be automatically connected to each other. It is therefore no longer necessary to wire these connections separately from instrument to instrument, significantly reducing the costs of installation.

The instruments are connected to the:

- FRAKO Starkstrombus
- Display bus, including the Display instrument power supply



Figure 2: DIN rail bus connector

3.1 Connections

The EM-PQ 2300 Power Quality Analyzer has the following connections:

Inputs

- 5 voltage measurement inputs for L1 / L2 / L3 / N / PE (or free for other uses)
- 5 current transformer measurement inputs for L1 / L2 / L3 / N / PE (or free for other uses)
- 4 S0 pulse inputs for tariff switching, triggering synchronized energy metering with power supplier, acquisition of pulse signals, alarms and statuses
- Pt100 or Pt1000 temperature input in 4-wire or 2-wire configuration

Outputs

- 1 alarm contact
- 2 digital outputs programmable either as:
 - Pulse contact to output 2 energy readings or
 - Status contact to output alarm signals
- 2 analogue outputs to output any 2 desired measurements as 0–20 mA, 4–20 mA or 0–10 V signals

Interfaces

- RS-485 bus, FRAKO Starkstrombus® protocol for connection to the FRAKO Energy Management System
- Ethernet (RJ45 port) with the following functions:
 - FTP downloading (for measurement protocols)
 - FRAKO Starkstrombus® via Ethernet for this instrument (for FRAKO internal communications).
 - Alternatively Modbus TCP
 - The internal alarm system can transmit e-mails via Ethernet or access text messaging (SMS) services. Transmission rate 10 Mbit/s or 100 Mbit/s.
- Display bus (CAN bus) for connecting the optional EM-FD 2500 Display instrument

3.2 LEDs

The six LEDs on the EM-PQ 2300 have the following functions:

In front of the casing, from left to right

- ● Run (green) Instrument in operation, flashes at 1-second intervals.
- ● Bus (yellow) Indicates access to the FRAKO Starkstrombus® or the Modbus.
- ● Alarm (red) Indicates presence of alarm signals and instrument faults.
- ● Digital Out 1 (blue) Lights up when digital output 1 transmits a signal
- ● Digital Out 2 (blue) Lights up when digital output 2 transmits a signal

In the base near the Display connector

- Overcurrent (red) Lights up if the output to the Display instrument is overloaded.

4. Mounting the instrument

4.1 Suitable location

The EM-PQ 2300 is intended for installation in stationary, weather-protected control cabinets and enclosures. We recommend installation in a metal cabinet or a shielded enclosure to protect against adverse environmental factors such as corrosion, pollution and stray radiation.

Provided that high quality EMC-compliant connecting cables are used and the instrument is installed in a metal cabinet or a shielded enclosure, it can be reasonably assumed that the emission limits of EN 55011/22 Class B (office and residential area) will be complied with.

The EM-PQ 2300 Ethernet connection is at the top of the casing. A free space of at least 50 mm must be allowed above the EM-PQ 2300 because of the minimum allowable bending radius of the Ethernet cable and the type of connector used.

4.2 Installing the instrument

The EM-PQ 2300 is intended for fixed installation in control cabinets or enclosures; see *Section 4.1 Suitable location, page 11*.

The instrument has a standard casing designed for mounting on a 35 mm DIN top hat rail (TS 35 as per EN 50022). A rail length of 161.6 mm is required, any desired rail orientation being permitted.

The electrical connections between several suitable devices of the FRAKO Energy Management System can be simplified with DIN rail bus connectors offered separately by the manufacturer, **Phoenix Contact**, under the order code **HBUS 161,6-16P-1S BK, Article No. 2278555**. These are fitted in the DIN top hat rail underneath the EM-PQ 2300 before it is snapped over the rail. See *Section 3, Instrument description, page 10*. This simplifies the interconnecting wiring of the devices.

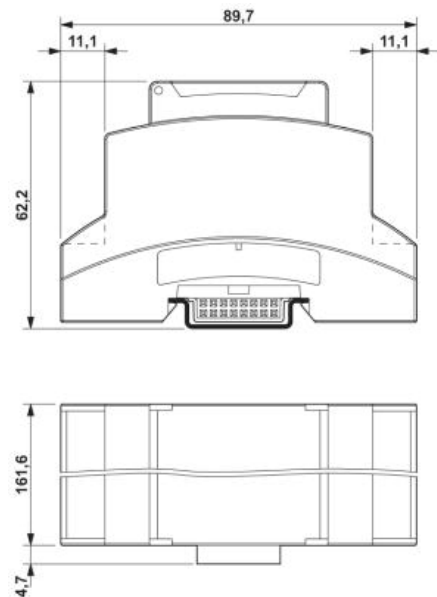

Figure 3: Dimensions

**CAUTION!**

It is not permitted to operate the instrument other than in a dust-tight control cabinet. In dusty environments, the ventilation slots in the casing can become blocked, resulting in overheating of the instrument or even a fire.

Only install the instrument in a control cabinet that guarantees a dry, dust-free interior environment.

**DANGER!**

The PQC must not be installed in a hazardous zone, as its switching operations generate sparks that could ignite flammable gases.

Only install the instrument in areas where there is no danger of a gas or dust explosion.

The instrument is mounted by snapping it over a DIN top hat rail (see example in Figure 4).

1. Use a screwdriver to retract all the orange retaining clips from the instrument base until they click into place.
2. Place the instrument over the DIN top hat rail. If the optional DIN rail bus connector is used to connect the FRAKO Starkstrombus and the Display bus for several devices, ensure that the pin strip in the base of the casing is correctly inserted in the socket strip on the DIN rail bus connector.
3. Press the orange retaining clips back into the casing until they click audibly into place flush with the edge of the instrument base.

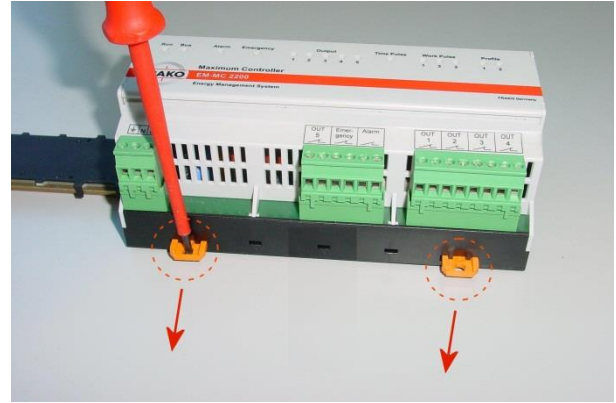

Figure 4: Retracting the retaining clips



CAUTION!

A DIN rail bus connector may only be connected to the DIN rail bus connectors of other FRAKO devices.

Connection to other types of DIN rail bus connectors from other manufacturers can damage or destroy the EM-PQ 2300 and any connected devices not from FRAKO. The risk of fire can also not be excluded.

It is therefore not permitted to connect with other types of DIN rail bus connectors from other manufacturers.

5. Installation

Prerequisite: the instrument has been correctly fitted to the DIN rail as described in *Section 4, Mounting the instrument, page 11*.

If the cabling is not EMC-compliant, it is possible that Class A emission limits (industrial environment radiation) may be exceeded. However, when high quality EMC-compliant connecting cables are used and the instrument is installed in a metal cabinet or a shielded enclosure, it can be reasonably assumed that the emission limits of EN 55011/22 Class B (office and residential area) will be complied with.

In cases of interference from the supply network, we recommend installing a broadband filter in the line to the instrument.

We recommend keeping cable lengths as short as possible and using shielded cables or possibly absorber cables.

It can happen that the EMC emission limits are exceeded if the EM-PQ 2300 is used in combination with other devices.

5.1 Electrical connections

The instrument is connected as shown in *Figure 5 and Figure 6, page 14*.

**DANGER!**

The following instructions must be observed to avoid danger to life and limb:

- When the instrument is being installed or serviced, the instrument and the electrical system must be isolated from the power supply.
- The isolated electrical system must be locked out to prevent its being inadvertently switched on again.
- It must be verified that none of the instrument connections are live!
- The power supply and voltage measurement connections are live and must not be touched!
- The measurement terminals L1, L2, L3, N and PE, plus the instrument power supply terminals L and N and both alarm contacts must be short-circuited during any work carried out on the instrument.
- All live components in the vicinity must be covered to prevent inadvertent contact.
- If the power supply voltage and the voltage measured exceed the values specified in this operating manual and stated on the EM-PQ 2300, this may cause damage to the instrument. Consequential damage to other parts of the installation is also possible.
- The instrument power supply circuit and the voltage measurement connections must all be protected externally by 2 A slow-blow 250 V AC fuses.
- Only the specified and appropriate voltages and signals may be connected to the respective terminals and ports provided for them.
- The cross-sectional areas of all cables used must be adequate for the purpose.
- Suitable measures must be taken to prevent cables operating at the power supply voltage being inadvertently pulled out and twisted.
- A disconnecting device, such as an isolator or circuit breaker, must be fitted in the building electrical installation in a suitable location, accessible by the user and appropriately labelled as a disconnecting device for the EM-PQ 2300. It must be able to isolate all cables operating at the power supply voltage from the instrument.
- If flexible stranded cables with their total cross-sectional area assembled from several fine filaments are used for the connections, ferrules must be crimped onto their ends. It must be ensured that no individual filament has been left out of the ferrule.

When work is carried out on the connecting cables and the instrument terminals, it is possible that live components may be touched inadvertently. If this occurs, the voltage present may be injurious to health or may even have fatal consequences.

Observing the above safety precautions can significantly reduce the risk to life and limb.

**NOTE!**

The instrument can be damaged by incorrect operation.

- Only the specified and appropriate voltages and signals may be connected to the respective terminals and ports provided for them.
- The cross-sectional areas of all cables used must be adequate for the purpose.
- The required cable types are specified in *Section 2, Technical data, page 8*.

If any incorrect cables, voltages or signals are applied to the terminals, this can result in damage to the EM-PQ 2300 and the electrical installation.



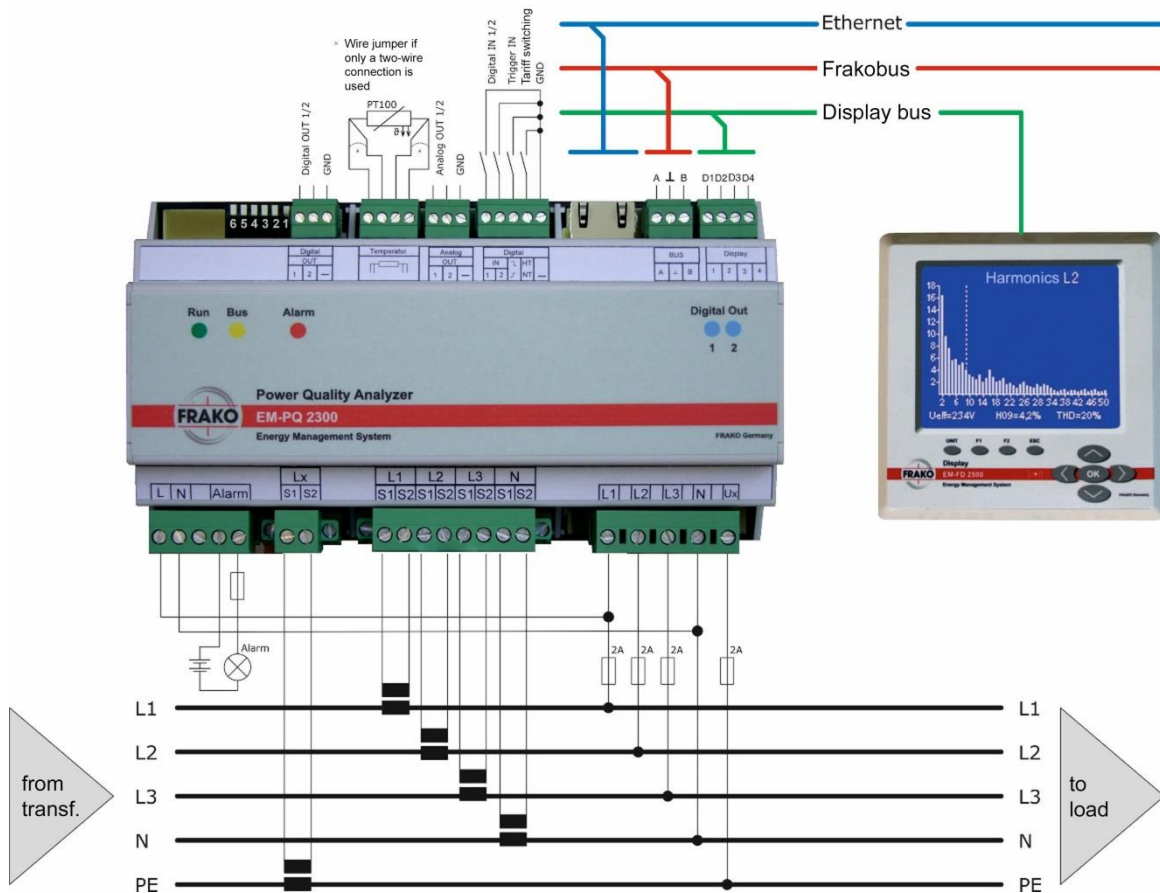

Figure 5: 3-phase connection diagram

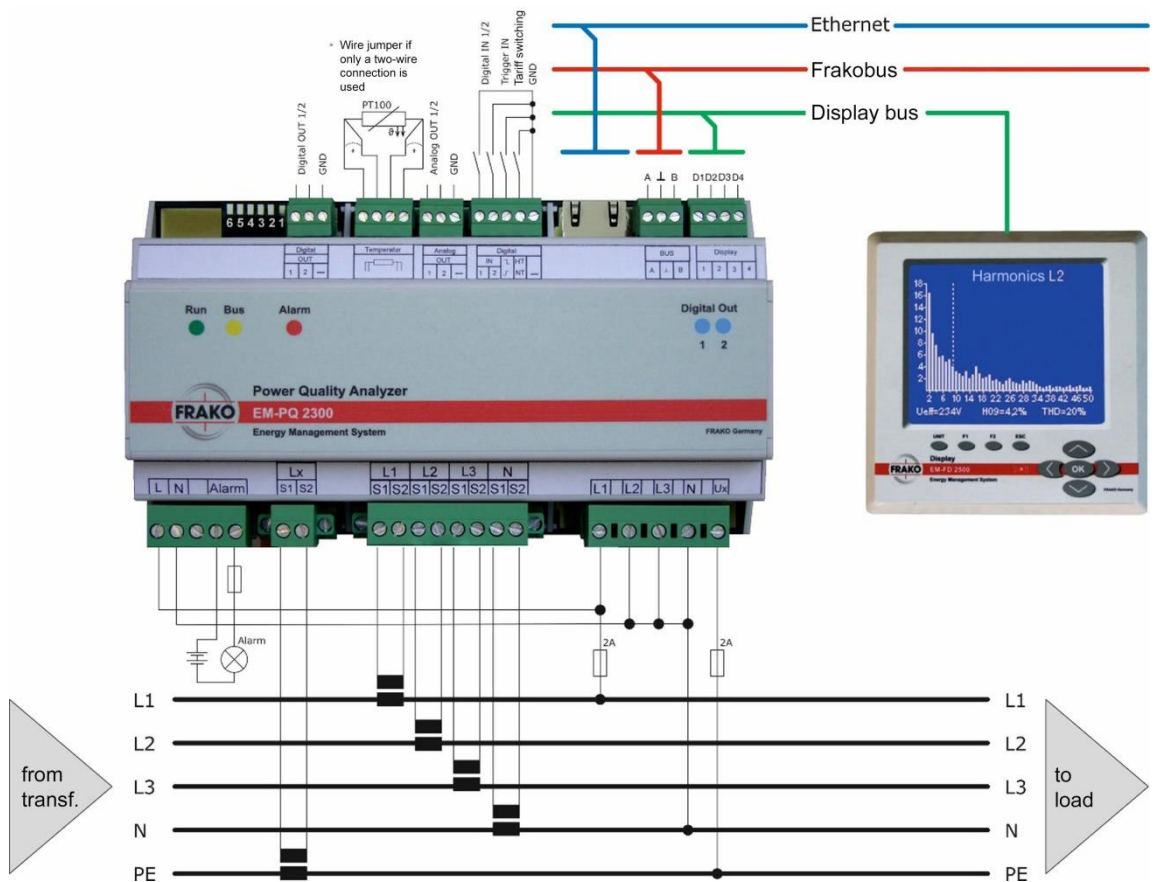

Figure 6: Single-phase connection diagram

Installation can be further simplified with the optional **DIN rail bus connector**, which can be obtained from the manufacturer, **Phoenix Contact**, with the order code **HBUS 161,6-16P-1S BK, Article No. 2278555**. This enables the bus connections of the EM-PQ 2300 Power Quality Analyzer or EM-MC 2200 Maximum Optimizer instruments mounted next to each other on the same DIN rail to be automatically connected to each other. It is therefore no longer necessary to wire these connections separately from instrument to instrument, significantly reducing the costs of installation.



The instruments are connected to the:

- FRAKO Starkstrombus
- Display bus, including the Display instrument power supply

5.1.1 Instrument power supply



DANGER!

To avoid accidents, the following must be observed:

- The safety instructions in *Section 5, Installation, page 12*

When work is carried out on the instrument terminals and connecting cables, there is a risk of live components being touched inadvertently. The working voltage may present a hazard to health or may even be life-threatening.

Observing the above safety precautions can significantly reduce the risk to life and limb and potential damage to equipment.

The instrument power supply is 90–267 V AC, frequency 45–65 Hz, or 100–360 V DC (absolute limits). It is connected to terminals **L** and **N** as shown in the diagrams *Figure 5* or *Figure 6, page 14*.



CAUTION!

The cables leading to the instrument must be permanently connected. It is not permitted for these to have plug-in connections.

- An external disconnecting device, such as an isolator or circuit breaker, must be fitted in the power supply line to the instrument. This must be located in the vicinity of the EM-PQ 2300 and must be able to isolate both the L1 and N cables. It must be suitable for this application, comply with the requirements of IEC 60947-1 and IEC 60947-3, and be appropriately labelled as a disconnecting device for the EM-PQ 2300. This device must not disconnect the earthing conductor.

5.1.2 Measurement connections

5.1.2.1 Voltage measurement

The EM-PQ 2300 can measure five AC voltages, whose respective inputs are electrically interconnected via high resistances. See *Section 2, Technical data, page 7* for the measurement ranges. DC voltages cannot be measured.

The voltage measurement inputs of the EM-PQ 2300 are intended for 110–600 V AC networks.

It is possible to measure medium voltages using an $x/100$ V transformer.

Note: A **690 V MEASUREMENT RANGE EXTENSION KIT (Article No. 20-30243)** is available for the direct measurement of voltage in 690 V AC networks.

If the 690 V measurement range extension kit is used, a **voltage transformer factor of 1.5** must be entered when the instrument parameters are configured.

	<p>DANGER!</p> <p>To avoid accidents, the following must be observed::</p> <ul style="list-style-type: none"> • The safety instructions in <i>Section 5, Installation, page 12</i>. <p>When work is carried out on the instrument terminals and connecting cables, there is a risk of live components being touched inadvertently. The working voltage may present a hazard to health or may even be life-threatening.</p> <p>Observing the above safety precautions can significantly reduce the risk to life and limb.</p>
---	--

The preferred arrangement is to connect all three phases L1, L2 and L3, plus the neutral conductor N and the protective earth PE. Instead of the PE conductor, another voltage source can also be connected, provided that its parameters are within the range specified in *Section 2 Technical data, page 7*.

This 3-phase connection is to the terminals **L1, L2, L3, N** and **Lx** as shown in the diagram *Figure 5, page 14*, where in addition the variables in the N and PE conductors are also measured.





Figure 6, page 14, shows the alternative single-phase connection.

It is advisable to connect the N conductor as well as the three phases.

This enables the high measurement accuracy of the EM-PQ 2300 to be achieved when measuring phase-neutral voltages and the parameters derived from these. If no neutral conductor is present, the **N** terminal can be left unconnected. However, in this situation a virtual star point arises in the instrument, which implies that the values of the phase-neutral voltages are nearer to each other than necessarily the case. The parameters derived from these values will be similarly misleading.

Leaving N unconnected is only advisable when the phases are symmetrically loaded, since as a rule the phase-neutral voltages here are near to each other in value.





	<p>NOTE!</p> <p>The voltage measurement inputs not in use must be commoned with the terminal N. This is necessary, for example, with single-or two-phase connections.</p> <p>If this is not done, phantom measurement readings may be displayed for the inputs that are not in use.</p>
--	---

	<p>NOTE!</p> <p>When the Lx terminal is connected to the PE conductor to measure the voltage in it, as shown in Figures 5 and 6, a green/yellow cable must only be used between the connection point in the installation and the 2 A fuse, never between the fuse and the terminal Lx on the EM-PQ 2300. The cable between the fuse and the terminal Lx must have a completely different colour!</p> <p>If this is not ensured, it is possible that the terminal Lx on the EM-PQ 2300 may then be mistaken for a normal PE connection, and an additional earth conductor could be commoned there as well. This would be incorrect, since it is not permitted to route PE connections through disconnecting devices such as fuses.</p>
---	--

5.1.2.2 Current measurements

The EM-PQ 2300 is designed for connection to x/1 A and x/5 A current transformers. Only AC currents can be measured, not DC currents.

	<p>DANGER!</p> <p>To avoid accidents, the following must be observed:</p> <ul style="list-style-type: none"> • The safety instructions in <i>Section 5, Installation, page 12</i> • The current measurement inputs must be connected as specified. <p>When work is carried out on the instrument terminals and connecting cables, there is a risk of live components being touched inadvertently. The working voltage may present a hazard to health or may even be life-threatening.</p> <p>Observing the above safety precautions can significantly reduce the risk to life and limb and potential damage to equipment.</p>
---	--

	<p>DANGER!</p> <p>Live current transformer circuits must never be interrupted. There is a danger that arcing may occur, which could cause burns or electric shock.</p> <p>The secondary-side connections of the current transformers must be short-circuited at the transformers before the circuits to the EM-PQ 2300 are interrupted!</p> <p>Exceptions: If the current transformers in use are equipped with internal open circuit protectors in good working order in the secondary circuits, or if a test switch that automatically short-circuits the current transformer secondary side is fitted. In the latter case, it is essential that the correct functioning of the short-circuiting switch has been verified before it is then left in the 'Test' position for any work on the circuit.</p> <p>Note: Modern current transformers installed in power systems are, as a rule, equipped with an internal open circuit protector, which acts to protect the secondary circuit upon this being opened. However, it is absolutely essential that the presence of an open circuit protector in good working order be verified before a current transformer secondary circuit is opened.</p> <p>A safe procedure is to short-circuit the secondary side on the current transformer side of the terminals to be opened.</p>
	<p>DANGER!</p> <p>Live current transformer circuits must never be interrupted. There is a danger that arcing may occur, which could cause burns or electric shock.</p> <p>The retaining screws on the sides of the connectors for the current transformer circuits must always be tightened before the instrument is put into service.</p> <p>Tightening these retaining screws prevents the connectors from accidentally working loose and therefore reduces the risk of arcing.</p>
	<p>DANGER!</p> <p>If an earth terminal is provided at the secondary side of the current transformer, this must be connected to an earthing conductor!</p>
	<p>CAUTION!</p> <p>The following must be observed to ensure safe and reliable operation:</p> <ul style="list-style-type: none"> • The connection of the current measurement inputs must be via an external, electrically isolating current transformer. • Overloading of the current transformers incorporated in the instrument must be avoided. The maximum allowable continuous current is 6 A AC; transient peaks 10 A. <p>These measures must be taken to ensure that the instrument is not damaged.</p>

The EM-PQ 2300 can measure five AC currents, whose respective inputs are electrically isolated from each other. See *Section 2, Technical data, page 7* for the measurement ranges.

The currents in the phases L1, L2 and L3, plus those in the neutral conductor N and the protective earth conductor PE, are measured via external current transformers. Instead of the protective earth another conductor can also be connected, provided that its parameters are within the range specified in *Section 2, Technical data, page 7*.

The terminals **L1 – S1-S2**, **L2 – S1-S2**, **L3 – S1-S2**, **N –S1-S2** and **Lx – S1-S2** must be connected as shown in the connection diagram Fig. 5 on page 14. This shows the 3-phase connections with the additional measurements in the N and PE conductors.



Unassigned current measurement inputs can be left unconnected.

**NOTE!**

In networks with a nominal voltage of 1000 V or more, the regulations call for the current transformer circuits to be earthed. At lower voltages, this is not required, but is nevertheless recommended.

All the S2 terminals, for example, can be commoned to earth, but it must be checked beforehand whether the current transformer circuits are already earthed in the installation.

In general, it is recommended that all current transformer circuits be earthed.

In networks with a nominal voltage of 1000 V or more, damage may occur to the instrument if the circuits are not earthed.

5.1.3 Ethernet connection

The EM-PQ 2300 has a shielded RJ45 jack at the top for connecting it to a hub or switch. Its pole assignment corresponds to an MDI interface, so that a 1:1 cable must be used; Category 5 is adequate. Possible transmission rates are 10 Mbit/s or 100 Mbit/s, half-duplex or duplex; the EM-PQ 2300 automatically selects the highest possible setting.

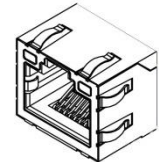
**CAUTION!**

Incorrect network settings can cause network errors.

5.1.4 Connecting to the FRAKO Starkstrombus®, alternatively Modbus

Figure 7: FRAKO Starkstrombus

Field of application

The FRAKO Starkstrombus can be used for communication between a PC and the EM-PQ 2300, using either an EMIS 1500 Central Unit (data collector and bus coupler) or an EMG 1500-PN Gateway (Ethernet bus coupler). This is a practical solution if the FRAKO Starkstrombus is already installed and a direct connection via Ethernet is not possible, otherwise the direct communication via Ethernet is preferable to that via the FRAKO Starkstrombus.

Connection

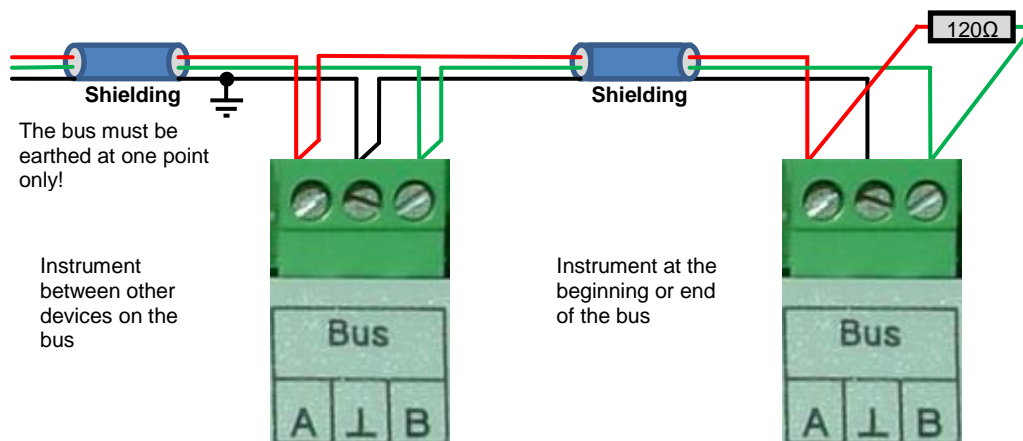
The EM-PQ 2300 uses an RS-485 interface at the terminals 'BUS A, \perp , B' to connect to the FRAKO Starkstrombus. See Figure 7 on page 18.

Terminal **A** is commoned with all other **A** connections in the bus. Similarly, all **B** terminals are commoned, as are all \perp terminals (no crossover of wires!). The shielding is connected to the \perp terminal.

The bus shielding (\perp) must be earthed at one—and only one—point in the bus system. If earthing has not already been done at some other point, it can be done at the EM-PQ 2300.

A bus topology (i.e. single line) must be used, with all devices wired in series or linked to the bus by drop lines no longer than 2 m. Star topologies can be constructed using an EMB 1101 Repeater, available as an accessory.

The total length of the bus should not exceed 1000 m. An EMB 1101 Repeater must be installed to cover greater distances.

A 120 Ω terminating resistor must be installed at each end of the bus by connecting it between the terminals **A** and **B**. In bus systems with fewer than 4 devices, a 1 k Ω resistor must also be connected between the terminals **A** and **L**. The resistors must be rated at 250 mW.

**NOTE!**

The bus shielding (**L**) must be earthed at one point in the bus system. If earthing has not already been done at some other point, it can be done at the EM-PQ 2300.

However, the **bus must only be earthed at one point!**

If this is not done, damage can occur to the bus interfaces of all connected devices, and data transmission can be disrupted.

**NOTE!**

A 120 Ω terminating resistor must be installed at each end of the bus by connecting it between the terminals **A** and **B**. In bus systems with fewer than 4 devices, a 1 k Ω resistor must also be connected between the terminals **A** and **L**. The resistors must be rated at 250 mW.

Without terminating resistors, the data transmission can be disrupted. It is also possible that no functioning data link can be established between the devices.

Recommended cable types:

Surge impedance 100–120 Ω ; \varnothing 0.5 mm²; shielded twisted pairs;

Types: IBM Twinax
EIB bus cable
Lapp Unitronic J-2Y (ST) Y
Siemens YCYM 4 × 2 × 0.8 or PYCYM 4 × 2 × 0.8

**NOTE!**

A mixing of different cable types must always be avoided.

The use of different cable types can disrupt data transmission. It is also possible that no functioning data link can be established between the devices.

5.1.5 Display bus

The EM-PQ 2300 can be connected by a suitable bus cable to an optional EM-FD 2500 Display instrument, which enables the EM-PQ 2300 to show its measurement readings, graphs, alarms and operating structures.

Figure 8: EM-FD 2500 Display

Other suitable FRAKO Energy Management devices can also be connected to this bus, provided that the technical specifications of the bus system are complied with in the cable connections.

The bus system used is the CAN bus.

The EM-FD 2500 Display obtains both its instrument power and its data via the four poles of its male connector.

The connector poles of the EM-FD 2500 Display are assigned as follows:

- Poles 1 and 4 (outer): instrument power = first twisted pair
- Poles 2 and 3 (inner): data transfer = second twisted pair

The cable shielding can be connected to pole 4.

If a suitable cable is used, the length of the complete bus system can be up to 40 m.

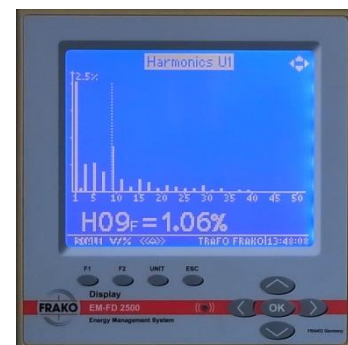

Cables

There are CAN bus cables on the market with their conductors assembled as twisted pairs, for example those from Lapp Cables, as well as cables with the conductors stranded, such as those offered by Helukabel. If twisted pairs are used, one pair must be used for poles **1** and **4**, and the other pair for poles **2** and **3**. With stranded conductors, any one of them can be used for any connection.

Suitable CAN bus cables:

Manufacturer	Lapp Cables	Helukabel
Installation method		
Fixed installation up to 30 m in length	UNITRONIC [®] BUS CAN UL/CSA (CMX) 2 × 2 × 0.22, Article No. 2170 261	CAN BUS 4 × 1 × 0.22 Article No. 81287
Fixed installation up to 40 m in length	UNITRONIC [®] BUS CAN UL/CSA (CMX) 2 × 2 × 0.34, Article No. 2170 264	CAN BUS 4 × 1 × 0.34 Article No. 801573
Highly flexible installation up to 40 m in length	UNITRONIC [®] BUS CAN UL/CSA (CMX) 2 × 2 × 0.25, Article No. 2170 273	CAN BUS 4 × 1 × 0.50 Article No. 800685

	<p>NOTE!</p> <p>The data transmission rate of the CAN bus is 1 Mbit/s. According to ISO 11989, this means that if a suitable uninterrupted cable with core cross sections of 0.25 mm² is used, the maximum length of the bus will be 40 m.</p> <p>The use of unsuitable cable types can disrupt data transmission. It is also possible that no functioning data link can be established between the devices.</p>
---	--

5.1.5.1 Requirements for the bus cabling

- A bus topology (i.e. single line) must be used.
- All devices must be wired in series in the bus.
- Drop lines and star topologies are not permitted.
- The total length of the bus must not exceed 40 m. See *Section 5.1.5.2 Cable types*, below for the cable types to be used and their limitations.
- At the beginning and end of the bus, the terminating resistors incorporated in the devices must be activated. With the other devices that are not located at either end of the bus, the internal terminating resistors must be deactivated.

	<p>NOTE!</p> <ul style="list-style-type: none"> • To ensure fault-free operation, it is important that the twisted pairs in the cable be correctly connected: One twisted pair is connected to the outer poles 1 and 4, the other to the inner poles 2 and 3. With conductors that are all stranded together, any one of them can be used for any connection. • The maximum bus length of 40 m for suitable cable must not be exceeded. • A maximum of 7 devices plus one EM-FD 2500 Display or 6 devices plus two EM-FD 2500 Displays may be connected to the same bus segment, however no more than one EM-FD 2500 Display per EM-PQ 2300 or EM-MC 2200 may be connected. <p>If these instructions are not complied with, data transmission may be disrupted. It is also possible that no functioning data link can be established between the devices.</p>
---	---

5.1.5.2 Cable types

The following cable types or others with equivalent specifications must be used.

Surge impedance 120 Ω:

- For fixed installation up to 30 m
Lapp UNITRONIC^(R) BUS CAN UL/CSA (CMX) 2 × 2 × 0.22, Article No. 2170 261
Helukabel CAN BUS 4 × 1 × 0.22, Article No. 81287
- For fixed installation up to 40 m
Lapp UNITRONIC^(R) BUS CAN UL/CSA (CMX) 2 × 2 × 0.34, Article No. 2170 264
Helukabel CAN BUS 4 × 1 × 0.34, Article No. 801573

- For highly flexible installation up to 40 m
Lapp UNITRONIC^(R) BUS CAN UL/CSA (CMX) 2 × 2 × 0.25, Article No. 2170 273
Helukabel CAN BUS 4 × 1 × 0.50, Article No. 800685

5.1.5.3 Number of devices on the Display bus

A maximum of 7 devices plus one EM-FD 2500 Display or 6 devices plus two EM-FD 2500 Displays may be connected to the same bus segment.

One EM-PQ 2300 can supply instrument power to one EM-FD 2500 Display, so that only one EM-FD 2500 may be connected per EM-PQ 2300. No more EM-FD 2500 Display instruments may be connected than there are EM-PQ 2300 or EM-MC 2200 devices connected on the Display bus.

5.1.5.4 Terminating resistors

A terminating resistor must be in the circuit at each end of the bus. With the EM-PQ 2300, this is done with the configuration switch 1 (DIP switch 1). When this rocker switch is pressed down towards the base of the instrument, the internal terminating resistor is switched in, otherwise the resistor is not in the circuit. Similarly, an internal terminating resistor is also incorporated in the EM-FD 2500 Display. This resistor is activated with the instrument's keys, as described in *Section 6.4 Terminating resistors on the Display bus, page 24*.

5.1.6 Digital OUT 1/2

The EM-PQ 2300 has two digital outputs (standard S0 pulses as per DIN 43864), which can be used to transmit status codes.

The assignment of status codes to the digital outputs is carried out using the FRAKO configuration software Device Manager.

For technical data see *Section 2, Technical data, page 7*; for configuration see *Section 7.2.1 Digital OUT 1/2, page 28*.



CAUTION!

Please pay attention to the following points when connecting the instrument:

- Common earth connection, also electrically connected with the digital inputs, analogue outputs and temperature input
- If more than one external earthing connections are made, equalizing currents could flow through them and cause damage to the EM-PQ 2300 or other devices connected to it.

5.1.7 Analog OUT 1/2

The EM-PQ 2300 has two analogue outputs, which can transmit measurement readings.

The assignment of measurement readings to the analogue outputs is carried out using the FRAKO configuration software Device Manager.

For technical data see *Section 2, Technical data, page 7*; for configuration see *Section 7.2.2 Analog OUT 1/2, page 28*.



CAUTION!

Please pay attention to the following points when connecting the instrument:

- Do not apply any voltages from other sources.
- Common earth connection, also electrically connected with the digital inputs, analogue outputs and temperature input.
If more than one external earthing connections are made, equalizing currents could flow through them and cause damage to the EM-PQ 2300 or other devices connected to it.

5.1.8 Digital IN 1/2, Trigger IN, tariff switching

The EM-PQ 2300 has four digital inputs (for standard S0 pulses as per DIN 43864), which can be used to read status codes.

The inputs **1**, **2** and **Trigger IN** are available for use as desired, **Trigger IN** also being designated as input **3**, as it is actually identical with inputs **1** and **2** in terms of its functionality. The input HT/NT, on the other hand, serves only for tariff switching.

The configuration of inputs **1-3** (status code or pulse reception and their assignment to a variable) is carried out using the FRAKO configuration software Device Manager.



See *Section 2, Technical data, page 7*, and *Section 7.3.1 Digital IN 1/2, page 28*, for the configuration procedure.



CAUTION!

Please pay attention to the following points when connecting the instrument:

- Common earth connection, also electrically connected with the digital inputs, analogue outputs and temperature input.
- If more than one external earthing connections are made, equalizing currents could flow through them and cause damage to the EM-PQ 2300 or other devices connected to it.

5.1.9 Temperature IN

The EM-PQ 2300 has one temperature input, to which either a Pt100 or a Pt1000 RTD probe can be connected. The EM-PQ 2300 automatically identifies the type of probe connected, 2-wire or 4-wire configuration being possible.

If a 2-wire configuration is used, each outer connection must be commoned with the inner connection next to it.

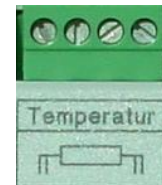

For technical data see *Section 2, Technical data, page 7*; for configuration see *Section 7.3.2 Temperatur, page 29*.



CAUTION!

Please pay attention to the following points when connecting the instrument:

- Common earth connection, also electrically connected with the digital inputs, analogue outputs and temperature input.
- If more than one external earthing connections are made, equalizing currents could flow through them and cause damage to the EM-PQ 2300 or other devices connected to it.

Note: Temperature measurement is possible from hardware version v1.8 and firmware version v1.72 onwards. Although the connections are provided in earlier instrument versions, they have no function. If a temperature probe is connected there, it will not result in any technical faults, but false temperature readings will be output.

5.1.10 Alarm

Alarm signals registered internally in the EM-PQ 2300 can be assigned to the volt-free contact of the alarm relay. These alarm signals can comprise status codes, statuses of digital inputs, set alarm limits exceeded or instrument faults.

The assignment of the internal alarm signals to the alarm relay is carried out using the FRAKO configuration software Device Manager.



For technical data see *Section 2, Technical data, page 7*; for configuration see *Section 7.2.3 Alarm rela, page 28*.

6. Commissioning (initial start-up)

6.1 Safety precautions before start-up



DANGER!

To avoid accidents, the following must be observed:
Before start-up, it must be ensured, for example by means of a closed door or a suitable cover, that the instrument terminals can no longer be touched.

If the instrument terminals and connecting cables remain exposed during operation, there is a risk of live components being touched inadvertently. The working voltage may present a hazard to health or may even be life-threatening if this happens.

Observing the above safety precautions can significantly reduce the risk to life and limb.

After all installation work has been carried out as described in *Section 5, Installation, page 12*, and the above safety precautions have been taken, the power supply may be switched on and the EM-PQ 2300 started up

6.2 Functional checkout

When the power is switched on, the **Run** LED lights up. After about 20 seconds, the EM-PQ 2300 is ready to operate and the **Run** LED starts flashing at 1-second intervals.

If an EM-FD 2500 Display instrument is connected, a red LED located on the base near the Display connector serves as an overcurrent annunciator. If it lights up or flashes, the current to the EM-FD 2500 is too high. This will not damage the EM-PQ 2300, but short-circuiting the Display connections can restart the EM-PQ 2300 repeatedly in a 2.5-second cycle.

The cable connections to the Display should then be inspected for faults in such a case.

6.3 Configuration switches (DIP switches)

The DIP switches on the EM-PQ 2300 are used to make basic settings.

The DIP switches are located on the top left of the instrument near the terminals.

Switch 1 is nearest to the middle of the instrument.

ON position: The white rocker is pressed down.

OFF position: The white rocker is pulled up.

Figure 9: Configuration switches (DIP switches)

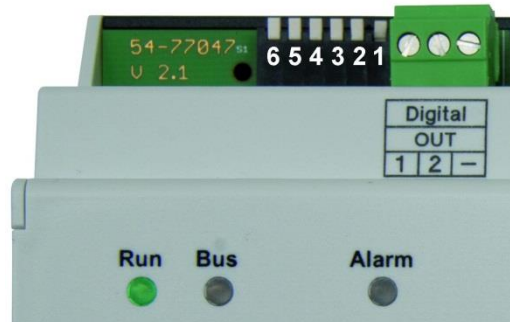

6.3.1 Functions of the DIP switches



CAUTION!

Incorrect network settings can cause network errors.

Switch	Function	OFF	ON
1	Display bus terminating resistor	Terminating resistor deactivated	Terminating resistor activated
2	DHCP	Switched off	Switched on
3	Network IP address	As per configuration	Fixed as in table below
4 & 5	Mode of the RS-485 interface	See below	See below
6	Not assigned	-	-

6.3.2 DHCP options

DHCP can be activated both via DIP switch 2 and via the "Network / bus settings" display menu. This results in the following behavior:

- When DHCP is switched on, the EM-PQ 2300 automatically obtains the IP address from a DHCP server. Which IP address has been assigned to the device must be requested by the EDP. It should be ensured that the EM-PQ 2300 is always assigned the same IP address.
- In the optional EM-FD 2500 display, the static IP address is always displayed even when DHCP is switched on, which only applies if DHCP is switched off.
- DHCP can also be switched on or off on the EM-FD 2500 display, but the DIP switch setting "ON" takes precedence.
If DHCP is used permanently, it should be enabled via the DIP switch.
- If DHCP is switched off, the device will again use the network configuration that was valid before the DHCP was switched on and is shown in the display EM-FD 2500.
- If DHCP is turned on without a network cable connected, the device will not receive an IP address. Even if a network cable is connected later, depending on the firmware version, there is no automatic IP address assignment. Only after switching the EM-PQ 2300 off and on with the network cable plugged in, the device receives an IP address from the DHCP server.

6.3.3 Fixed network IP address

IP address	192.168.0.57
Subnet mask	255.255.255.0
Gateway	none
DNS	none

6.3.4 Mode of the RS-485 interface

DIP switch 4	DIP switch 5	Function
OFF	OFF	FRAKO Starkstrombus
OFF	ON	reserved
ON	OFF	reserved
ON	ON	reserved

6.4 Terminating resistors on the Display bus

The terminating resistors incorporated in the devices at the beginning and end of the single-line bus must be activated. There must be exactly two resistors switched in!

All FRAKO devices that can be operated on the Display bus are provided with an internal terminating resistor that can be switched in and out. With the EM-PQ 2300, this is done with the configuration switch 1 (DIP switch 1). When the switch is pressed down towards the base of the instrument, the internal terminating resistor is switched in, otherwise the resistor is not in the circuit. No external resistors need to be connected to the Display bus!

	<p>NOTE!</p> <ul style="list-style-type: none"> • A terminating resistor must be activated at each end of a single-line bus. With the EM PQ 2300, this is done with the configuration switch 1 (DIP switch 1). When the switch is pressed down towards the base of the instrument, the internal terminating resistor is switched in, otherwise the resistor is not in the circuit. • In the EM PQ 2300 as delivered, the terminating resistor is activated (configuration switch 1 down). • With the EM-FD 2500 Display, an internal terminating resistor can be activated with the instrument's keys. The procedure is described in the EM-FD 2500 operating manual. • There must be exactly two resistors switched in! With any other number, the bus communication will be disrupted. • If the two activated terminating resistors are not located at the end of the line, or if the wrong number of resistors have been activated, this will upset communication between the devices and the EM-FD 2500. <p>If these instructions are not complied with, data transmission may be disrupted. It is also possible that no functioning data link can be established between the devices.</p>
---	--

6.4.1 Activating the terminating resistor in the EM-FD 2500

The terminating resistor incorporated in the EM-FD 2500 is activated and deactivated using that instrument's keys. Please refer to the EM-FD 2500 operating manual for the procedure.

	<p>NOTE!</p> <p>In the EM-FD 2500 Display as delivered, the terminating resistor is activated.</p> <p>An incorrect number of terminating resistors on the bus can disrupt data transmission. It is also possible that no functioning data link can be established between the devices.</p>
---	---

6.4.2 Activating the terminating resistors in other devices

Please refer to the appropriate operating manual for the procedure. As a rule, the FRAKO software Device Manager is needed to perform this configuration.

6.4.3 Address assignment

The device addresses are assigned automatically on the CAN bus. The EM-FD 2500 Display operating manual describes the interrogating procedure for the assigned addresses of the EM-FD 2500 Display and every other connected device.

6.5 Installation of the FRAKO software Device Manager

	<p>Please note!</p> <p>If FRAKONET is already installed on the PC, Device Manager cannot be installed as well. In this case, install FRAKONET Version 1.22.0000 or a later version. These include Device Manager in the software. Start Device Manager by selecting the EM-PQ 2300 in the SYSTEM-SW system tree and then 'Configure device' in the context menu.</p>
---	---

6.5.1 IT requirements

Hardware requirements:

- IBM-compatible PC with a CPU of at least 2 GHz
- 1 GB RAM
- 200 MB free hard disk space
- Network connection

Software requirements:

- Windows 7 (32 or 64 bit) or Windows 2008 Server R2 or Windows XP SP2 with .NET Framework 3.5 installed

6.5.2 Installation

Windows 7, Windows 2008 Server R2:

- ☞ Start Windows Explorer.
- ☞ In the main menu of the installation CD start the file **setup.exe**.

Windows XP:

Device Manager requires that .NET Framework 3.5 SP1 be already installed. If this is not the case, please install .NET Framework now.

- ☞ Start Windows Explorer and then start the file **dotnetfx35.exe** in the **NET Framework 3.5 SP1** folder on the installation CD.
- ☞ In the main menu of the installation CD then start the file **setup.exe**.

6.5.3 Configuration of the EM-PQ 2300

Configuration can only be carried out using the PC software EMPQ-SW included in Device Manager. It is not possible to perform a complete configuration from the optional EM-FD 2500 Display.

The instructions for configuring the EM-PQ 2300 are given in the online help of EMPQ-SW, which is accessed by clicking the  button.

7. Configuration

7.1 Address assignment

7.1.1 Ethernet

7.1.1.1 Default values for network setting

IP address	192.168.0.57
Subnet mask	255.255.255.0
Gateway	none
DNS	none

7.1.1.2 Configuration of the network setting

For access via Ethernet, the EM-PQ 2300 needs a unique IP address. The simplest way to set this is via the optional EM-FD 2500 Display. If this instrument is not installed, the IP address can be assigned by DHCP or by using the Device Manage software.



NOTE!

- The specified gateway must be located within the subnet, and the specified subnet mask must comply with the IP rules.
- The selected IP address must be unique in the selected subnet.
- The EM-PQ 2300 operates exclusively with IPv4 addresses.

If the network settings are incorrectly configured, the instrument will not be accessible via Ethernet.

Assigning the same IP address to two devices in the subnet will result in disrupted communication with both the EM-PQ 2300 and the other device.

7.1.1.2.1 Setting the IP address on the EM-FD 2500 Display instrument

If an EM-FD 2500 Display is installed, the IP address can simply be entered at this instrument, using the following procedure:

- Press the **UNIT** key to display the list of devices.
- Select the appropriate device and press the **OK** key.
- Select the menu item **Network / Bus Settings** to open the window for configuration of the IP address.
- Make certain that the setting **User def'd below** (= user-defined, see below) is displayed under **IP settings by DIP switch**. If this is not the case, move the DIP switches 2 and 3 on the EM-PQ 2300 to the OFF position.
- Enter the IP address, subnet mask and gateway address.
- The EM-PQ 2300 should now be accessible at the new IP address.

7.1.1.2.2 Obtaining the IP address from the DHCP server

It is possible to obtain the IP address dynamically from a DHCP server. To do this, DIP switch 2 at the top of the instrument casing must be in the **ON** position, and the IP address assigned by the DHCP server must be known. In addition, the EM-PQ 2300 must always receive this same IP address.

The network administrator requires the MAC address of the instrument in order to be able to assign an IP address to the EM-PQ 2300. The MAC address is printed at the top of the instrument casing.

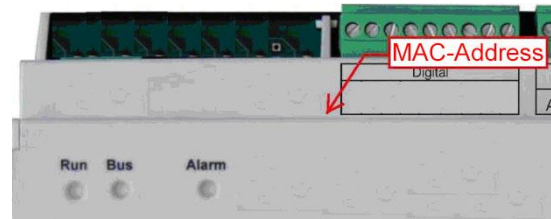

Figure 10: Location of the MAC address (typical example)

7.1.1.2.3 Setting the IP address without an EM-FD 2500 Display

If no EM-FD 2500 Display is installed, the IP address must be programmed as follows:

Please note!

For the procedure described below, the EM-PQ 2300 must be located in the same subnet as the PC with which the EM-PQ 2300 is to be configured. If this is not the case, the EM-PQ 2300 must be temporarily connected directly to the PC with a crossover cable.

- If not yet done, install FRAKO Device Manager on the PC.
- Move DIP switch 3 on the EM-PQ 2300 to **ON**. The instrument now has the IP address 192.168.0.57.
- Note the IP settings of the PC and then set an IP address of 192.168.0.x, where x is any number between 1 and 255 (but excluding the number 57), at the PC. Set the subnet mask at 255.255.255.0.
- Start Device Manager and add a connection to the EM-PQ 2300 with the IP address 192.168.0.57.

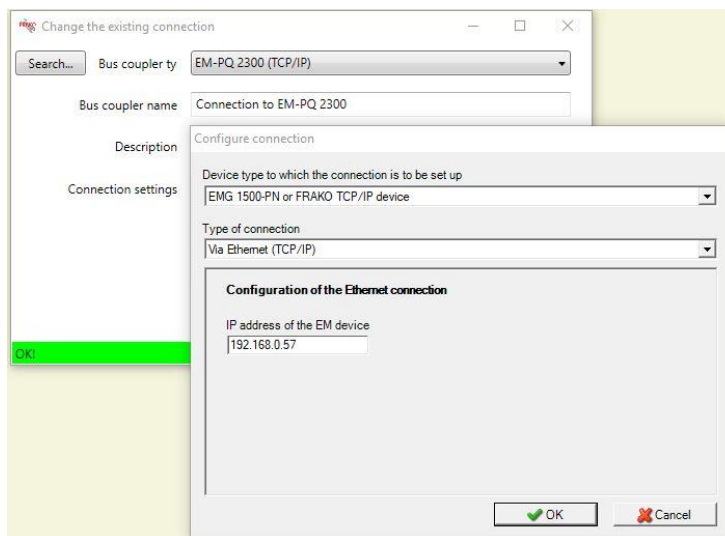

- Select the connection and then from its context menu the item **Search for devices**. An EM-PQ 2300 with the bus address 0 should then be found. (The same device may possibly be found again with another bus address, but this one can be ignored.)
- Activate the check box of the EM-PQ 2300 found at the bus address 0 and click OK to close the window.
- Now select the newly added device under the connection to display the pane with the configuration software for the device at the right of the device tree.
- Under **Set up / Communication** select **Set up interfaces (Frakobus*, Ethernet)**. (Frakobus is the short form of FRAKO Starkstrombus®.)
- Enter the future IP parameters in the **TCP/IP settings** section.
- Click the Back button to close the page.
- Click the  button to write the configuration to the EM-PQ 2300.

- Answer the following warning with **No**:

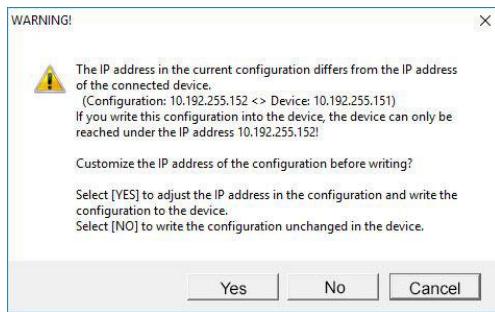

- Move DIP switch 3 on the EM-PQ 2300 to the **OFF** position. The instrument is now accessible at its normal IP address, so it is therefore no longer accessible under the current connection.
- Reset the IP parameters of the PC back to their original values.
- Select the current connection in the device tree and then **Configure connection** from its context menu.
- In the configuration window for the connection, enter the same IP address that was entered for the EM-PQ 2300 configuration.
- Save the device tree by clicking the  button.
- Close Device Manager then restart it.
- The EM-PQ 2300 should now be accessible at its normal IP address.

7.1.2 FRAKO Starkstrombus®

See *Section 8.1.16 Configuration, Configuration page, page 33*, and *Section 8.1.17 Configuration, Changing the setting parameters / Password entry, page 33*, for assigning addresses with the EM-FD 2500 Display.

An address can be configured at the PC using the EMPQ-SW configuration software included in Device Manager.

7.1.3 Display bus

The device addresses are assigned automatically on the Display bus.

It is possible to interrogate for the assigned address at the EM-FD 2500 Display. The procedure is described in the EM-FD 2500 operating manual.

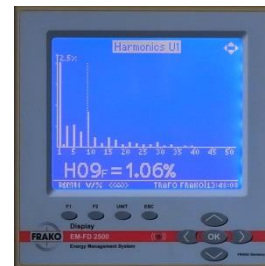

7.1.3.1 Terminating resistors on the Display bus

Please refer to *Section 5.1.5.4 Terminating resistors, page 21*.

7.2 Outputs

7.2.1 Digital OUT 1/2

Switching statuses and status codes that are registered internally in the EM-PQ 2300 can be assigned as signals to the two digital outputs. The FRAKO configuration software Device Manager is required to do this.

7.2.2 Analog OUT 1/2

The analogue outputs are not yet supported by Version 1.00.

7.2.3 Alarm relay

The assignment of the internal alarm signals to the alarm relay is carried out using the FRAKO configuration software Device Manager.

7.3 Inputs

7.3.1 Digital IN 1/2

The digital inputs can either be status inputs (e.g. for indicating alarm conditions and alerting maintenance personnel by e-mail) or pulse inputs for connecting to utility meters with pulse outputs. From the pulses received, the EM-PQ 2300 can compute and record energy and power.

The digital inputs are configured using the software EMPQ-SW included in Device Manager. The instructions for this configuration task are given in the online help of Device Manager in the section **EMPQ-SW Operating Manual**.

7.3.2 Temperature

Either a Pt100 or a Pt1000 RTD probe can be connected to the temperature input. The EM-PQ 2300 automatically identifies the type of probe connected.

8. Operation

8.1 Via the EM-FD 2500 Display instrument

Configuration is carried out using the PC software EMPQ-SW included in Device Manager. The instructions for configuring the EM-PQ 2300 are given in the online help of Device Manager in the section **EMPQ-SW Operating Manual**.

This describes the configuration procedure by means of the optional EM-FD 2500 Display instrument. It is not possible, however, to perform a complete configuration from the EM-FD 2500 Display. Measurement readings can be displayed and several key parameters set, but the start-up of the EM-PQ 2300 is not possible only from the EM-FD 2500 Display.

A maximum of 7 devices plus one EM-FD 2500 Display or 6 devices plus two EM-FD 2500 Displays may be connected to the same Display bus.

8.1.1 Geräte / Devices page

Devices are selected on the **Geräte / Devices** page. Pressing the **UNIT** key from anywhere in the user dialogue displays this page.

The EM-PQ 2300 is selected by scrolling with the ▲, ▼ keys on the EM-FD 2500 Display. It is recognized by the



symbol shown here on the right. The first 16 characters of the device name are shown on the Display screen. It is therefore wise to choose the device name so that it can be identified uniquely just by its first 16 characters.



After the device has been selected, the keys have the following functions:

Taste	Function
F1	SET UP Opens the Display Set up page, where the screen brightness and contrast can be adjusted. In addition, the Display terminating resistor is activated here. Pressing the F2 (INFO) key from here causes information on the Display instrument itself (not on the devices served by the Display) to be shown, such as version, serial number and Display bus address.
F2	INFO Shows information on the currently selected device, such as version, serial number and Display bus address.
UNIT	Has no function on this page. Elsewhere this key is used to open the Geräte / Devices page.
ESC	Has no function on this page. Elsewhere this key is used to switch to one menu level higher.
OK	Confirms the currently selected menu item and opens the corresponding page.
< / >	Here these keys have the same function as the OK key. Elsewhere these keys are used to turn pages horizontally.
▲/▼	Selects the next or previous device.

Once a device has been selected, pressing **F2** (INFO) reveals its version, serial number and Display bus address.

8.1.2 Start menu page

Once a device has been selected on the **Geräte / Devices** page, use the ▲, ▼ and OK keys to open the Start menu.

Using the ▲ and ▼ keys on the Display, choose between the menu items **Display**, **Basic settings**, **Network / Bus Settings** and **Sprache / Language**.

Selecting **Display** opens **General overview**, showing momentary phase variables, THD V/I, harmonics, graphs, TN-S measurements, energy meters or active alarms.

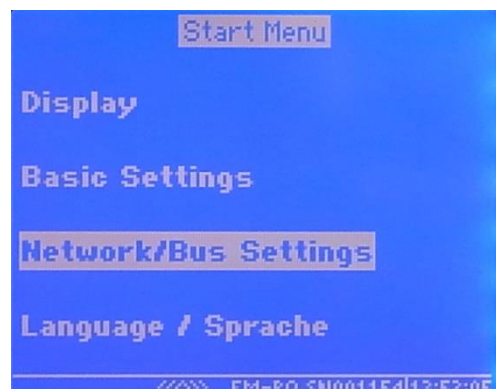

Selecting **Basic settings** makes it possible to make the following settings:

- Current transformers L, N, PE
- Voltage transformers L (L1/L2/L3), PE (Lx)
- Displayed name
The displayed name is the one listed on the device selection page of the Display. It must be no longer than 15 characters.

Selecting **Network / Bus Settings** makes it possible to enter the IP settings and the FRAKO Starkstrombus address. If DIP switches 2 (DHCP) and 3 (fixed IP address 192.168.0.57 overrides DIP switch 2) on the EM-PQ 2300 are at OFF, the following settings can be made at the Display:

- DHCP:
Regardless of the DIP switch position, DHCP can also be activated at the Display. When DHCP is active, the following IP settings have no significance.
- IP address, Subnet mask, Gateway, DNS 1, DNS 2:
These settings are only significant if DHCP has not been activated, whether by DIP switch 2 or at the Display, and no fixed IP address has been set using DIP switch 3.

The following settings can always be specified, regardless of the DIP switch position:

- FRAKO Starkstrombus address

At **Sprache / Language**, the language used in the Display, in the text for the events read from the instrument and in the e-mails it sends can be switched between German and English.

Please note that after the language has been changed at the Display or via EMPQ-SW, the Display language does not change until the **Unit** key is pressed again to open the device selection page and the device is selected again.

8.1.3 Display, Overview page

Variable	Significance
Ptotal	Momentary active power computed from all inputs
Qtotal	Momentary reactive power computed from all inputs
Stotal	Momentary apparent power computed from all inputs
Power factor	Ratio of active power to apparent power
cos(phi)	Cosine of momentary angle of lag/lead
Frequency	Momentary network frequency
Current asymmetry	Momentary asymmetry in current path as percentage
Voltage asymmetry	Momentary asymmetry in voltage path as percentage

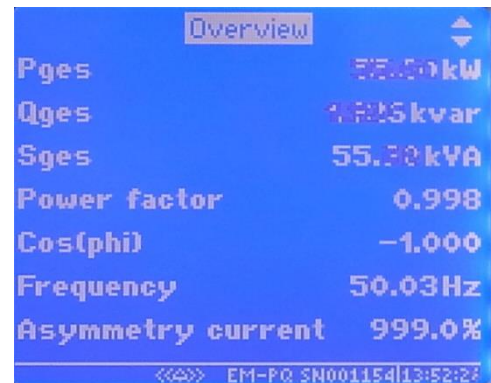

8.1.4 Display, Phase values page

Selecting the menu item **Phase values** in **Display** opens this page. Pressing the **ESC** key will close the page and return the user to the next higher menu level.

Variable	Significance
Vrms ph/n	Momentary RMS voltages between each phase (L1, L2, L3) and neutral (N)
Vrms ph/ph	Momentary RMS voltages between pairs of phases (L1/L2, L1/L3, L2/L3)
Irms	Momentary RMS currents in the individual phases (L1, L2, L3)
Power factor	Momentary power factors in the individual phases (L1, L2, L3)
cos(phi)	Cosine of momentary angle of lag/lead in the individual phases (L1, L2, L3)

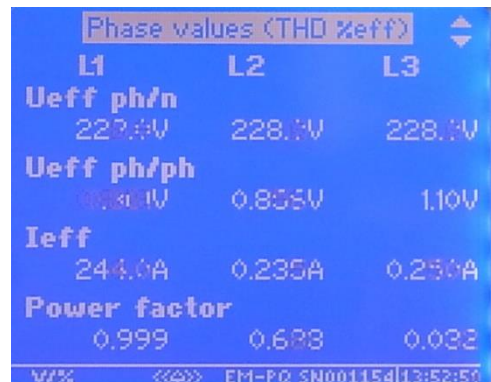

P	Momentary active power in the individual phases (L1, L2, L3)
Q	Momentary reactive power in the individual phases (L1, L2, L3)
S	Momentary apparent power in the individual phases (L1, L2, L3)
THD V %rms	Momentary percentage of voltage harmonics in the individual phases (L1, L2, L3)
THD I %rms	Momentary percentage of current harmonics in the individual phases (L1, L2, L3)

8.1.5 Display, THD/VI page

Selecting the menu item **THD VI** in **Display** opens this page. Pressing the **ESC** key will close the page and return the user to the next higher menu level.

Variable	Significance
THD V1	Momentary percentage of voltage harmonics in phase L1
THD V2	Momentary percentage of voltage harmonics in phase L2
THD V3	Momentary percentage of voltage harmonics in phase L3
THD I1	Momentary percentage of current harmonics in phase L1
THD I2	Momentary percentage of current harmonics in phase L2
THD I3	Momentary percentage of current harmonics in phase L3
THD IN	Momentary percentage of current harmonics in the neutral conductor N



8.1.6 Display, Harmonics page

Selecting the menu item **Harmonics** in **Display** opens this page. Pressing the **ESC** key will close the page and return the user to the next higher menu level.

Use the **▲** and **▼** keys on the Display instrument to choose between **Voltage** and **Current**.

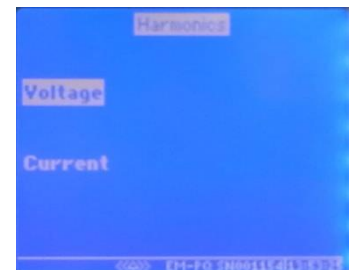

Selecting the menu item **Voltage** in **Harmonics** opens this page.

Use the **▲** and **▼** keys on the Display instrument to choose between the individual phases (V1, V2, V3).
Use the **<** and **>** keys on the Display instrument to select the harmonic to be shown as a measurement reading.

Selecting the menu item **Current** in **Harmonics** opens this page.

Use the **▲** and **▼** keys on the Display instrument to choose between the individual phases (I1, I2, I3, IN).
Use the **<** and **>** keys on the Display instrument to select the harmonic to be shown as a measurement reading.

8.1.7 Display, Graphs page

Selecting the menu item **Graphs** in **Display** opens this page. Pressing the **ESC** key will close the page and return the user to the next higher menu level.

Use the **▲** and **▼** keys on the Display instrument to choose between **Voltages** and **Currents**.
Use the **F1** and **F2** keys on the Display instrument to select the scale of the displayed graph (zoom function).

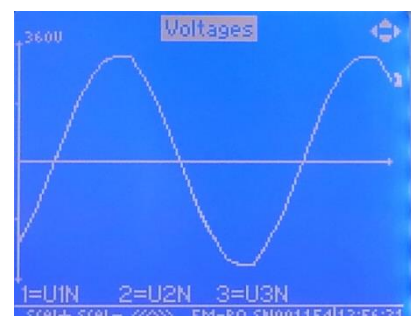

8.1.8 Display, TN-S measurement page

Selecting the menu item **TN-S measurement** in **Display** opens this page. Pressing the **ESC** key will close the page and return the user to the next higher menu level.

The following momentary measurement readings are displayed here:

- I PHmax
- I N
- I PE
- I Diff
- V PE-N
- I Diff / I PHmax



8.1.9 Display, Energy meter page

Selecting the menu item **Energy meter** in **Display** opens this page. Pressing the **ESC** key will close the page and return the user to the next higher menu level.

Use the **▲** and **▼** keys on the Display instrument to choose between **Energy total**, **Energy Tariff HT (A)**, **Energy Tariff NT (B)**.

Select one of these three windows to display the following measurement data for each energy meter:

Variable	Significance
P consumption	Active energy in kWh drawn from supply
P production	Active energy in kWh fed back to supply
Q ind	Inductive reactive energy in kvarh.
Q cap	Capacitive reactive energy in kvarh.
Q eff	RMS reactive energy in kvarh.
S	Apparent energy in kVAh.

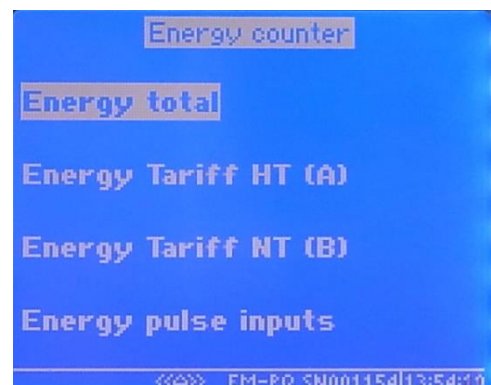

8.1.10 Display, Big display page

Selecting the menu item **big display** in **Display** opens this page. Pressing the **ESC** key will close the page and return the user to the next higher menu level.

Use the **▲** and **▼** keys on the Display instrument to choose between **Current**, **Voltage**, **Total power** and **TN-S measurement**.

8.1.11 Display, big display page, Current page

Selecting the menu item **Current** in **big display** opens this page. Pressing the **ESC** key will close the page and return the user to the next higher menu level.

Here the following measured variables are shown in large characters:

- I1
- I2
- I3
- IN



8.1.12 Display, big display page, Voltage page

Selecting the menu item **Voltage** in **big display** opens this page. Pressing the **ESC** key will close the page and return the user to the next higher menu level.

Here the following measured variables are shown in large characters:

- V1 (L1-N)
- V2 (L2-N)
- V3 (L3-N)
- Vx (Lx-N)

8.1.13 Display, big display page, Total power page

Selecting the menu item **Total power** in **big display** opens this page. Pressing the **ESC** key will close the page and return the user to the next higher menu level.

Here the following measured variables are shown in large characters:

- P total (Total active power)
- Q total (Total reactive power)
- S total (Total apparent power)
- PF (Power factor)

8.1.14 Display, big display page, TN-S measurement page

Selecting the menu item **TN-S measurement** in **big display** opens this page. Pressing the **ESC** key will close the page and return the user to the next higher menu level.

Here the following measured variables are shown in large characters:

- IN
- IPE
- Idiff
- VPE

8.1.15 Display, Active alarms page

Selecting the menu item **Active alarms** in **Display** opens this page. Pressing the **ESC** key will close the page and return the user to the next higher menu level.

The alarms currently present are displayed here.

8.1.16 Configuration, Configuration page

Selecting the menu item **Configuration** in the **Start menu** opens this page, where the most important settings for the EM-PQ 2300 can be made.

8.1.17 Configuration, Changing the setting parameters / Password entry

To change a setting in the configuration window, proceed as follows:

- Select the setting to be changed, then press the **OK** key.
- Enter the password in the box. The default password is the last four digits of the instrument serial number.

Use the **<** and **>** keys to select each digit, then change it with the **▲** and **▼** keys. Confirm with the **OK** key.

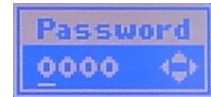

If the password is correct, the user can change parameters for the next 5 minutes, or until the device selection page is opened, without being prompted to enter the password again.

8.2 Web interface

The EM-PQ2300 web interface can be accessed from a web browser by entering the IP address of the EM-PQ2300 (e.g. <http://192.168.0.57>) in the address bar.

8.2.1 Menu

Menu item	Subitem	Presentation
Start		Instrument, Help, System time
Information		Instrument-specific information
	Voltage	Voltage, Frequency, Harmonic distortion, Phase sequence
	Current	Current, Total harmonic distortion
	Harmonics	Visual presentation up to the 51st harmonic
	Power	Active, reactive and apparent power, S0 power, Power factor
	Energy	Active, reactive and apparent power, S0 meter reading
	Periphery	Statuses of S0 pulse inputs and outputs
Recordings		
	Events	Recorded events
	System log	System messages
Configuration		
	Download	SNMP MIB, Operating manual, Modbus address table
	Firmware	Firmware update

8.2.2 Operation

The measurement readings are presented in tabular form. Each table can be automatically updated by clicking its context menu with the left mouse key.

8.2.3 Password

Some pages of the web interface require authentication. For user name, write '**system**'.

The EM-PQ 2300 instrument password can be used in the web interface, but needs to be changed once by the user in Device Manager. The procedure for doing this is described in the Device Manager online Help.

8.3 SNMP

Version 3 of Simple Network Management Protocol can be used. The required MIB (management information base) file can be downloaded from the web interface. The user name is '**system**'; a password is not required.

9. Maintenance

Except for the lithium battery installed in the EM-PQ 2300, the instrument does not need any maintenance.



DANGER!

The following instructions must be observed to avoid danger to life and limb:

- The instrument casing must not be opened. Exception: Opening the cover as described in *Section 9.2 Battery, page 35*, and in *Section 9.3, page 36*.

There are components at voltages inside the instrument that can endanger health or even be life-threatening if touched.

9.1 Cleaning the instrument



DANGER!

The following instructions must be observed to avoid danger to life and limb:

- During cleaning, the instrument and the connecting cables must be isolated from the power supply.
- The isolated electrical system must be locked out to prevent its being inadvertently switched on again.
- The immediate vicinity must be screened off.
- All connections must be checked to verify that they are no longer live!
- Power must not be switched on again to the installation until the cleaning work is completed.

When work is carried out in the vicinity of the instrument terminals and connecting cables, there is a risk of live components being touched inadvertently. A moist cleaning cloth, which conducts electricity, must never be used. The working voltage may present a hazard to health or may even be life-threatening.

If the above instructions are followed, the risk of endangering life and limb can be significantly reduced.

The instrument may only be cleaned with a dry cloth. When this is done, the above safety instructions must be followed. All power to the instrument must be switched off before cleaning is begun. Power must not be switched on to the instrument again until the cleaning procedure is completed.

9.2 Battery



DANGER!

The following instructions must be observed to avoid danger to life and limb:

- During installation work or servicing, the instrument and the connecting cables must be isolated from the power supply.
- The isolated electrical system must be locked out to prevent its being inadvertently switched on again.
- The immediate vicinity must be screened off.
- All connections must be checked to verify that they are no longer live!

When work is carried out on the instrument terminals and connecting cables, there is a risk of live components being touched inadvertently. The working voltage may present a hazard to health or may even be life-threatening.

Observing the above safety precautions can significantly reduce the risk to life and limb.

A lithium battery is fitted in the instrument to drive the internal clock in the event of power failure. It is located underneath the hinged cover printed with the instrument name. This cover can be opened downwards once the four tabs at the top edge of the cover have been carefully released.

The battery is a **CR2032 button cell** with a **nominal voltage of 3 V**.

At room temperature, the service life of the battery is about eight years; at an ambient temperature of 60 °C this reduces to about three years.

After battery replacement, the cover must be closed so that the tabs snap into place before the instrument is switched on again.

Once the new battery is fitted, the EM-PQ 2300 internal clock must be reset using the FRAKO configuration software Device Manager. The procedure for doing this is described in the Device Manager online Help.

9.3 Fuse

	<p>DANGER!</p> <p>The following instructions must be observed to avoid danger to life and limb:</p> <ul style="list-style-type: none">• During installation work or servicing, or when the internal fuse is to be replaced, the instrument and the connecting cables must be isolated from the power supply.• The isolated electrical system must be locked out to prevent its being inadvertently switched on again.• The immediate vicinity must be screened off.• It must be verified that none of the connections are live! <p>When work is carried out on the instrument terminals and connecting cables, there is a risk of live components being touched inadvertently. The working voltage may present a hazard to health or may even be life-threatening.</p> <p>Observing the above safety precautions can significantly reduce the risk to life and limb.</p>
---	--

An internal fuse is fitted in the EM-PQ 2300. It is mounted in a fuseholder underneath the hinged cover printed with the instrument name. This cover can be opened downwards once the four tabs at the top edge of the cover have been carefully released.

If the fuse needs to be replaced, the replacement fuse must have the following **specifications**:

Slow-blow, surge-proof fuse 2 A, 250 V AC, clearing I²t approx. 92.7 A²s, melting time at 10 × I_n at least 20 ms and no more than 300 s, size 5 x 20 mm

	<p>DANGER!</p> <p>The following instructions must be observed to avoid danger to life and limb or damage to equipment and other assets:</p> <ul style="list-style-type: none">• The fuse may only be replaced by the type specified above.• The clearing I²t rating must not be less than specified above, and the melting time at an overcurrent of 10 × I_n must be within the limits stated. <p>When work is carried out on the instrument terminals and connecting cables, there is a risk of live components being touched inadvertently. The working voltage may present a hazard to health or may even be life-threatening.</p> <p>Observing the above safety precautions can significantly reduce the risk to life and limb.</p>
---	---

After fuse replacement, the cover must be closed so that the tabs snap into place before the instrument is started up again.

10. Decommissioning and removal, storage and disposal

10.1 Decommissioning and removal

When decommissioning and removal work is carried out, please note the following:



DANGER!

The following instructions must be observed to prevent danger to life and limb or damage to equipment and other assets:

- When the instrument is removed, it is essential to switch off the power to the instrument and the installation beforehand.
- The isolated electrical system must be locked out to prevent its being inadvertently switched on again.
- All connections must be checked to verify that they are no longer live!
- The measurement connections L1, L2, L3, N and PE, the instrument power supply connections L and N, and both alarm contacts must be short-circuited whenever work is carried out on the instrument.
- All live components in the immediate vicinity must be covered to prevent inadvertent contact.

When work is carried out on the instrument terminals and connecting cables, there is a risk of live components being touched inadvertently. The working voltage may present a hazard to health or may even be life-threatening.

If the above instructions are followed, the risk of endangering life and limb or damaging equipment can be significantly reduced.



DANGER!

The following instructions must be observed to prevent danger to life and limb or damage to equipment and other assets:

- All live cables must be disconnected from the instrument.
- All disconnected cables must be individually isolated and insulated, and measures must be taken to prevent their inadvertent contact with live components or electrically conducting parts.
- If it is intended that connecting cables that have been disconnected from the instrument are to become live again after the instrument has been removed, adequate measures must be taken to prevent their inadvertent contact with other live components or electrically conducting parts.

Exposed electrical conductors that can be touched are a hazard to life and limb. If they come into contact with other electrically conducting components, the latter can also become live. In addition, cables designated only for low voltages can carry life-threatening higher voltages if they come into contact with cables at the supply network voltage.

To prevent this danger to life and limb, the exposed ends of disconnected cables must be individually insulated in a workmanlike manner. The ends of these cables must not be joined to each other, and it must be ensured that cable ends cannot be touched, and that they do not touch each other or other components.



CAUTION!

If the exposed ends of disconnected cables come into contact with each other, this can result in short-circuits and overloading of the installation conductors, resulting in damage to equipment and other assets.

All disconnected cables must be individually isolated and insulated, and measures must be taken to prevent their inadvertent contact with live components or electrically conducting parts.

10.2 Storage

- The EM-PQ 2300 must be stored in a clean, dry and dust-free location.

- The storage temperature must be within the range -20 °C to +80 °C.
- If the EM-PQ 2300 has been stored for several years, especially under relatively high temperatures, it is advisable to change its lithium battery before putting the instrument into service. See *Section 9.2 Battery, page 35*.

10.3 Disposal

Any electronic device that is no longer required must be disposed of in an environmentally sound manner.

	<p>CAUTION!</p> <p>Incorrect disposal can cause environmental pollution.</p> <ul style="list-style-type: none"> • In the European Union, electrical scrap and electronic components are subject to the WEEE (Waste Electrical and Electronic Equipment) Directive. These components must not be disposed of as normal domestic or commercial waste. • The backup battery fitted in the instrument must be disposed of separately for special treatment. See <i>Section 9.2 Battery, page 35</i>, for removal of the battery. <p>If these instructions are not complied with, there is a danger that environmental pollution may result and a violation of the Directive will have occurred</p>
---	---

In other countries, the equivalent local regulations must be followed when electronic devices are disposed of. They must be handed in at special recycling centres.

One way of ensuring environmentally sound disposal is to return the instruments to FRAKO Kondensatoren und Anlagenbau GmbH or the company's local representatives. Alternatively, the instruments can be given to a firm specializing in the recycling of electronic equipment.



11. General operating notes

The following points must be observed when operating the instrument:

- The instrument must always be operated in a closed control cabinet as described in *Section 4, Mounting the instrument, page 11*.
- All voltages applied to the instrument must never exceed the limits specified in the technical data. In the case of S0 pulse connections, the operating parameters must be within the range called for by DIN 43864.
- The ambient temperatures must always be within the range specified in the technical data.

The standard radio-frequency field test as per EN 61000-4-6 (EMC immunity) calls for amplitude modulation at a modulation frequency of 1 kHz. However, this frequency lies within the measurement range of the instrument in its intended use (20th harmonic of 50 Hz = 1 kHz). It is therefore to be expected that the measuring circuit clearly responds to this. For this reason, the radio-frequency field test can only be carried out without amplitude modulation.

Instrument operation is described in *Section 8, Operation, page 29*.

12. Troubleshooting

The table below offers help in troubleshooting any problems that may occur during operation of the EM-PQ 2300.

Symptoms	Possible cause	Remedy
Instrument power supply		
The green Run LED does not light up.	No instrument power	Check whether there is a 90–240 V AC voltage at the instrument power connection.
The green Run LED flashes every 2.5 seconds.	Short circuit at Display connection	Disconnect the Display connection as a test. If the Run LED now lights up continuously, then after a short time flashes at 1-second intervals, investigate the cause of the overload and rectify it.

The red LED near the Display connector lights up or flashes.	Display connection overloaded	Disconnect the Display connection as a test. If the red LED now goes off, investigate the cause of the overload and rectify it.
EM-FD 2500 Display instrument		
The EM-PQ 2300 is not shown in the Display main menu.	Fault in bus wiring	<ul style="list-style-type: none"> - Wiring fault - Cable length exceeds 40 m. - Unsuitable cable installed - Drop lines have been installed—only a single-line bus is permitted. - More than two—or less than two—terminating resistors are activated. - One or both terminating resistors are not located at the end(s) of the bus.
FRAKO Starkstrombus		
The instrument is not identified by Device Manager.	Bus wiring incorrect	Check wiring.
The instrument is not identified by Device Manager, or only sporadically; communication faults	Bus address already assigned to another device	Disconnect the EM-PQ 2300 from the bus and check the bus addresses with Device Manager. Is the address assigned to the EM-PQ 2300 still displayed? If yes, assign a new available address to the EM-PQ 2300.
Network/Ethernet		
No LED lights up on the RJ45 jack with the network cable plugged in.	Cable not fully home in the jack, not plugged in at the other end or incorrect cable type used	Press plugs fully home in the jacks at both ends. A standard cable must be used, not a crossover type.
Instrument cannot be accessed.	Incorrect configuration of the network parameters	Use an IP address that is valid in the network. Set the subnet mask in compliance with the network rules, if necessary specifying the correct gateway.
Digital outputs Digital OUT 1 und 2		
No output	No assignment to measured variables or events configured	These settings can be made and activated using the software Device Manager.

13. Scope of supply

- 1 EM-PQ 2300 instrument
- 10 assorted connectors, some coded, plugged into instrument
- 1 operating manual

Power Capacitors
Reactive Power Control Relays
Power Factor Correction Systems
Modules
EMS Components
Measuring Instruments and Power Quality Analysers
Power-Quality
EMS ISO 50001



FRAKO Kondensatoren- und Anlagenbau GmbH
Tscheulinstraße 21a
D-79331 Teningen
Tel: +49 7641 453-0
Fax: +49 7641 453-535
vertrieb@frako.com
www.frako.com