

Power Quality Analyzer EM-PQ 2200

Operating Manual

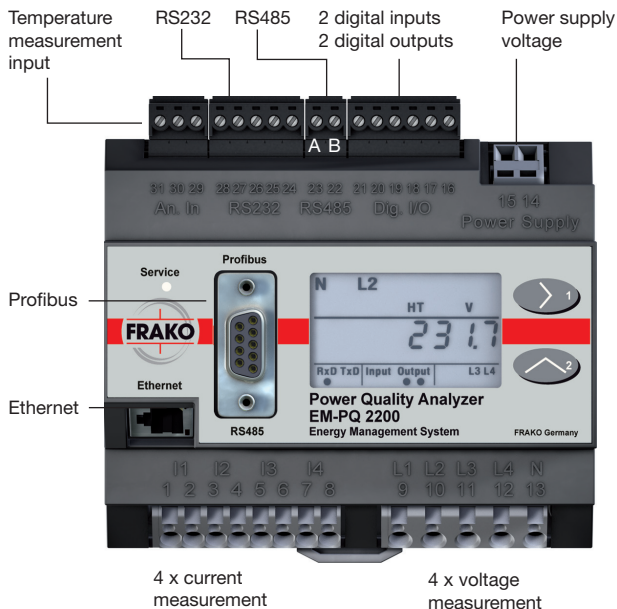

Contents

General Information	4	Operation	46
Inspection on receipt	6	Key functions	46
Scope of supply	7	Concealed key (service)	46
Available accessories	7	Display mode	47
Product Description	8	Use	48
Intended use	10	Programming mode	48
EM-PQ2200 features	11	Display password	49
Operating concept	12	Homepage password	49
EM-PQ VIS software	13	Measurements	50
Methods of measurement	14	Voltage transformer ratio	52
Three-phase 4-wire systems	15	Current transformer ratio	53
Three-phase 3-wire systems	16	Interfaces	54
Installation	18	RS232	54
Installed position	18	RS485	54
Power supply voltage	19	Ethernet	55
Voltage measurement	20	Profibus	56
Frequency measurement	27	Recordings	57
Current measurement	28	Putting into Service	58
Direct measurement	32	Applying the power supply voltage	58
Interfaces	34	Frequency measurement	58
RS485	36	Applying the measuring-circuit voltage	59
RS485 profibus DP V0 slave	38	Phase sequence	60
Digital inputs and outputs	40	Applying the measuring-circuit current	60
Temperature measurement input	44	Checking the energy measurement	61

Contents

System information	62	Appendix	78
Overrange	62	Parameter list	78
Serial number	63	Measured value displays	84
Date	63	Declaration of conformity	85
Firmware release	63	Dimensioned drawings	86
Time	63	EM-PQ2200 connection example	87
Service and maintenance	64	Quick Reference Instructions	88
Repair and calibration	64		
Front film	64		
Battery	64		
Firmware update	65		
Service	65		
Trouble shooting	66		
Technical specifications	70		
General information	70		
Ambient conditions during operation	70		
Transport and storage	70		
Power supply voltage	71		
Protection class	71		
Inputs and outputs	72		
Temperature measurement input	73		
Interfaces	74		
Measurement uncertainty	75		
Measuring inputs	76		
Voltage measurement	76		

General Information

Copyright

This manual is subject to the statutory copyright protection provisions and may not be photocopied, reprinted, reproduced as a whole or in parts, by mechanical or electronic means, nor copied or further published in any other way whatsoever without the legally binding, written consent of

FRAKO

Kondensatoren- und Anlagenbau GmbH

Tscheulinstr. 21a

D - 79331 Teningen, Germany

Comments on the manual

We welcome your comments. If anything in this manual seems unclear to you, please let us know by sending an eMail to:

info@frako.de

Protected trademarks

All trademarks and their resulting rights belong to the respective holders of these rights.

Liability disclaimer

FRAKO Kondensatoren- und Anlagenbau GmbH does not accept any responsibility whatsoever for errors or deficiencies within this manual and does not undertake any obligation to keep the content of this manual up to date.

Meaning of the symbols used

The following pictograms are used in this manual:



Dangerous voltage!

Danger or risk of severe injury. Disconnect the system and device from the power supply before starting the work.



Important!

Please note and follow the documentation. This symbol is intended to warn you of possible hazards that can occur during installation, starting up and use.



Note.

Inspection on receipt

Fault free and safe use of this device requires appropriate transport, proper storage, erection and assembly as well as careful operation and maintenance. If it can be assumed that safe operation is no longer possible, the device must be immediately taken out of service and secured against being accidentally started up. The device must be unpacked and packed with the usual care, without the use of force and only using suitable tools. The devices must be visually inspected for perfect mechanical condition. Please also note and follow the installation instructions enclosed with the device.

It can be assumed that safe operation is no longer possible if the device, e.g.

- has visible damage,
- no longer works, despite intact mains power supply,
- has been exposed to unfavourable conditions (e.g. storage outside the permissible climatic limits without adjustment to the ambient climate, condensation, or similar) for a lengthy period or was exposed to unfavourable effects or loads during transport (e.g. fall from a large height even if there is no visible external damage, or similar).

Please check the scope of supply for completeness before you start installing the device.



All screw-type terminals belonging to the scope of supply are plugged into the device.



The operating manual also describe options which do not belong to the scope of supply.



All supplied options and design versions are described on the delivery note.

Scope of supply

Number	Name
1	EM-PQ2200
1	Operating manual
1	CD with the following content: <ul style="list-style-type: none">- Configuration and visualization software „EM-PQ VIS“- Functional descriptions, EM-PQ VIS, EM-PQ2200 ..- GSD file “u6050c2d.GSD” for profibus DP V0
1	Screw-type terminal, plug-in, 2 pin.
1	Screw-type terminal, plug-in, 3 pin.
1	Screw-type terminal, plug-in, 5 pin.
1	Screw-type terminal, plug-in, 6 pin.
1	Slot-head screwdriver (0.40x2 mm), ESD
1	Patch cable, 3m, blue. (EM-PQ2200 - switch/hub connection)
1	Patch cable, 2m, twisted, grey. (EM-PQ2200 - PC connection)

Available accessories

Name
Battery, lithium CR2032, 3 V
RS485, external terminating resistor, 120 ohm
RS232, Connection cable (EM-PQ2200 – PC), 2m, 5 poles

Product Description

Notes on Use

Please read this operating manual and all other publications which have to be used to work with this product (in particular for installation, operation or maintenance).

Note and follow all safety instructions as well as any warnings. If you do not follow the instructions, personal injuries and/or damage to the product could be the result.

Any unauthorised change or use of this device which extends beyond the given mechanical, electrical or other operating limits can cause personal injuries and/or damage to the product.

Any such unauthorised change is “misuse” and/or “negligence” under the product's warranty and therefore excludes the warranty for cover of possible resulting injuries or damage.

This device may be solely operated and maintained by skilled persons.

Skilled persons are people who, on the basis of their relevant training and experience, are capable of identifying risks and avoiding possible hazards which operation or maintenance of the device can cause.

When using the device, any additional legal and safety regulations required for the respective use must be observed.

Product Description



Important!

If the device is not operated according to the instruction manual, protection is no longer ensured and the device can cause hazards.



Conductors made of individual wires must be fitted with wire end ferrules.



Only pluggable screw terminals with the same number of poles (pins) and of the same type may be plugged together.

Intended use

The EM-PQ2200 is intended to be used for the measurement and calculation of electrical variables such as voltage, current, energy, work, harmonic components, etc. in building installations, at distribution boards, circuit-breakers and busbar trunking systems.

Measuring-circuit voltages and currents must originate from the same system.

The EM-PQ2200 is permanently installed in control cabinets or small distribution boards. It can be installed in any position.

The measurement results can be displayed, stored and read out via serial interfaces and further processed.

The voltage measurement inputs are designed for measurements in low-voltage systems in which rated voltages up to 300 V conductor to earth and surge voltages of overvoltage category III can occur.

The current measurement inputs of the EM-PQ2200 are connected via external $\approx 1A$ or $\approx 5A$ current transformers.

Measurement in medium and high-voltage systems takes place with current and voltage transformers. Special safety requirements must be complied, which are not dealt with in any greater detail here.

The EM-PQ2200 fulfils the test requirements for use in industrial areas.

Mains failure detection

The mains failure detection takes place via the voltage measurement inputs. The selection of voltage measurement inputs can be configured using the EM-PQ VIS software.

Mains failure stored energy time

The EM-PQ2200 bridges the following mains failures at the auxiliary voltage input:

Mains voltage 230V AC	Stored energy time max 80ms
--------------------------	--------------------------------

EM-PQ2200 features

- Measurement in IT, TT and TN systems,
- 4 voltage measurement inputs, - 4 current measurement inputs,
- Continuous scanning of the voltage and current measurement inputs,
- Measurement of power quality according to DIN EN61000-4-30:2009 class S,
- Flicker meter according to DIN EN61000-4-15,
- Analysis and evaluation according to DIN EN50160 with EM-PQ VIS configuration and visualization software, which belongs to the contents of delivery,
- Measurement of harmonics and interharmonics (U_{In}, U_{II}, I) according to DIN EN61000-4-7,
- Measurement of audio remote frequency (U, I, P, Q),
- Detection of transients >50µs and storage with up to 16000 scanning points
- Detection of more than 2400 measurement values,
- Fourier analysis 1st to 63th harmonic component for U, I, P (cons./supply) and Q (ind./cap.),
- Detection of events such as overvoltage, voltage drop, power failure and overcurrent,
- Datalogger / event memory (128MB Flashdisk),
- Real energy; DIN EN62053-22, accuracy class 0,5S with/5A converter.
- Reactive energy; DIN EN62053-23, accuracy class 2r.
- 2 digital inputs, 2 digital outputs, temperature measurement input,
- LC display, 2 keys,
- Operating temperature range -10°C .. +55°C,
- Mounting on top hat rails 35 mm. Suitable for installation in distribution systems.
- Serial interfaces
 - Profibus DPV0,
 - RS485; modbus RTU, modbus,
 - RS232; modbus slave,
 - Ethernet; web server, EMAIL,
- Programming own applications in Jasic,

Operating concept

You can program the EM-PQ2200 and call up measured values in several ways.

- **Directly** at the device using 2 keys and the display. You can change the values in the parameter list (see Appendix) and call up the measured values from the measured value displays.
- Via the EM-PQ VIS configuration and visualization software.
- In devices with an ethernet interface, via the **homepage** of the EM-PQ2200.
- Via the RS485 with the **modbus** protocol. You can change and call up data with the help of the modbus address list (is filed on the enclosed data carrier).

Operation of the EM-PQ2200 via the integrated display and the two keys only is described in these operating instructions.

The EM-PQ VIS configuration and visualization software and the homepage have their own “online help”.



Use the **parameter list** in the appendix to these instructions for programming at the EM-PQ2200 and the **modbus address list** on the data carrier included in the scope of supply for programming via a serial interface.

EM-PQ VIS software

The EM-PQ2200 can be programmed and read out using the EM-PQ VIS configuration and visualization software included in the scope of supply. This requires a PC to be connected to the EM-PQ2200 via a serial interface/ethernet.

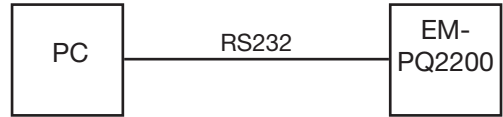

Fig. Connection of a EM-PQ2200 to a PC via an RS232 cable.

EM-PQ VIS features

- Programming the EM-PQ2200.
- Configuring recordings.
- Analyse der ausgelesenen Daten nach EN 61000-2-4.
- Reading out recordings.
- Storing data in a database.
- Graphic display of measured values.
- Programming customer-specific applications.

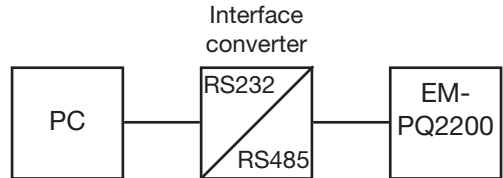

Fig. Connection of a EM-PQ2200 to a PC via an interface converter.

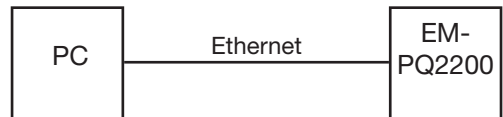

Fig. Connection of a EM-PQ2200 to a PC via the ethernet.

Methods of measurement

The EM-PQ2200 measures continuously and calculates all effective values over a 200 ms interval.

The EM-PQ2200 measures the real effective value (TRMS) of the voltages and currents applied to the measurement inputs.

Three-phase 4-wire systems

The EM-PQ2200 can be used in three-phase 4 conductor systems (TN, TT system) (50 Hz, 60 Hz) with earthed PEN conductor. The bodies of the electrical system are earthed. The conductor to neutral conductor voltage may not exceed 300 V AC.

The EM-PQ2200 is only suitable for environments in which the impulse voltage withstand level of 4 kV (overvoltage category III) is not exceeded.

U_{L-N} / U_{L-L}
66 V / 115 V
120 V / 208 V
127 V / 220 V
220 V / 380 V
230 V / 400 V
240 V / 415 V
260 V / 440 V
277 V / 480 V

Maximum rated voltage
of the grid

Fig. Table of rated voltages of the grid suitable for the voltage inputs.

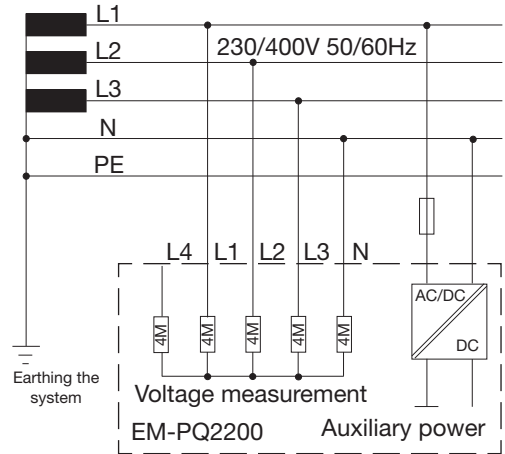

Fig. Block diagram, EM-PQ2200 in TN system.

Three-phase 3-wire systems

The EM-PQ2200 can be used in unearthed three-phase 3 wire systems (IT system). The conductor to conductor voltage may not exceed 480V AC (50 Hz, 60 Hz).

The EM-PQ2200 is only suitable for environments in which the impulse voltage withstand level of 4 kV (overvoltage category III) is not exceeded.

In the IT system the neutral point (star point) of the voltage generator is not earthed. The bodies of the electrical system are earthed. Earthing via high-resistance impedance is allowed.

IT systems are only allowed in certain systems with their own transformer or generator.

U_{L-L}
66 V
115 V
120 V
127 V
200 V
230 V
240 V
260 V
277 V
347 V
280 V
400 V
415 V
440 V
480 V

Maximum rated voltage
of the grid

Fig. Table of rated voltages of the grid suitable for the voltage inputs.

Product Description

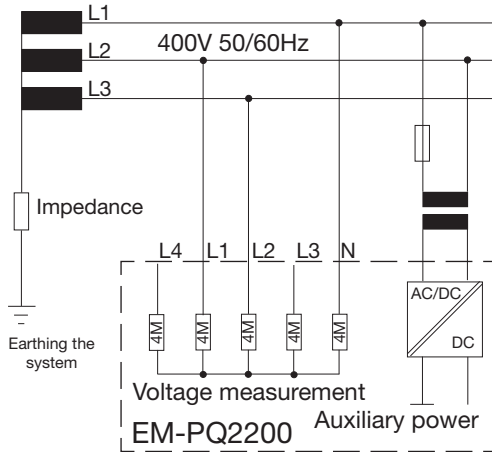

Fig. Block diagram, EM-PQ2200 in IT system without N.

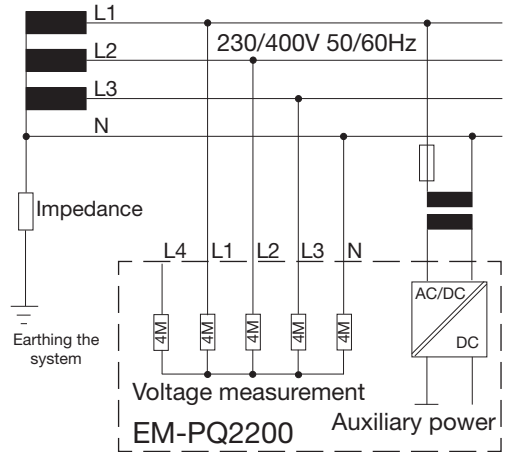

Fig. Block diagram, EM-PQ2200 in IT system with N.

Installed position

The EM-PQ2200 can be installed in control cabinets or in small distribution boards according to DIN 43880. It is mounted on a 35 mm mounting rail according to DIN EN 60715. It can be installed in any position.

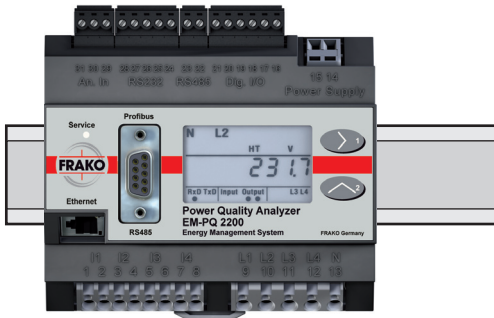

Fig. EM-PQ2200 on mounting rail according to DIN EN 60715.

Power supply voltage

A power supply voltage is required for operation of the EM-PQ2200. The type and amount of power supply voltage required is noted on the rating plate.

Before applying the power supply voltage, ensure that the voltage and frequency match the information given on the rating plate!

The connection cables for the power supply voltage must be fused with a UL listed fuse (6A type C).

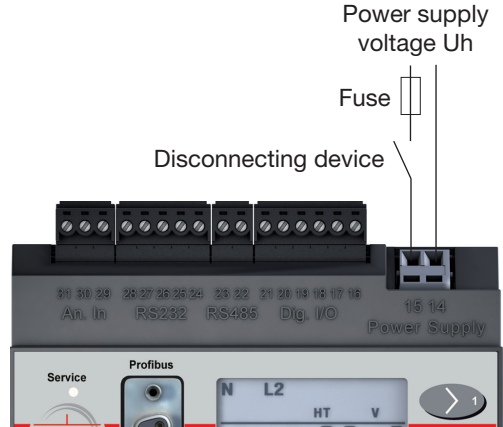

Fig. Connection example for the power supply voltage U_h .



- A disconnecter or circuit-breaker must be provided for the power supply voltage in the building installation.
- The disconnecter must be installed near the device and must be easy for the user to reach.
- The switch must be labelled as a disconnecting device for this device.
- Voltages which are above the allowable voltage range can destroy the device.



Warning!

Please pay attention to the details on the supply voltage provided on the EM-PQ2200 label.



Devices driven with direct current are protected against polarity reversal.



Important!

The inputs for the supply voltage are dangerous to touch!

Voltage measurement

The EM-PQ2200 is designed for the measurement of alternating voltages in 300 V systems in which category III overvoltages can occur.

The EM-PQ2200 can only determine measured values if a measurement-current voltage greater than $10 V_{eff}$ is applied to at least one voltage measurement input.

The following must be noted when selecting the instrument leads for the voltage measurement:

- The instrument leads required for the voltage measurement must be suitable for voltages up to 300 VAC to earth and 520 VAC conductor to conductor.
- Normal instrument leads must be fused by an overcurrent protective device and routed via disconnectors.
- Short-circuit proof instrument leads must be routed via disconnectors only.

Overcurrent protective devices and disconnectors must be positioned near the device and must be easy for the user to reach.

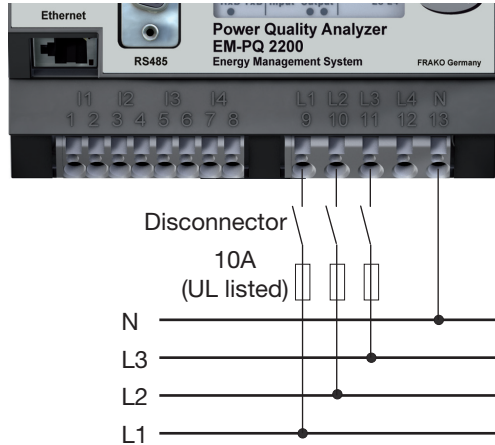

Fig. Connection example: Voltage measurement via short-circuit proof instrument leads.



Important!

The voltage measurement inputs are hazardous live!



The EM-PQ2200 can only determine measured values if a measurement-current voltage greater than $10 V_{eff}$ is applied to at least one voltage measurement input.

Frequency measurement

The EM-PQ2200 needs the network frequency to measure and calculate measurement values. The network frequency must be in a range between 15Hz and 440Hz.

For automatic ascertainment (wide range) of the frequency, an L1-N voltage larger than 10Veff must be applied to the voltage measurement input V1.

The measurement of power frequency happens only at the measuring inputs of the main measurement (V1, V2, V3).



Measurement voltages and measurement currents must come from the same network.



Be connected for the measurement of the auxiliary measurement (V4) for frequency estimation needs a voltage to the main measurement.



In case of a three wire main measurement (input V1-V3), the auxiliary measurement (input V4) cannot be used as measuring input.

Installation

Main measurement, inputs 1-3

4-conductor connection

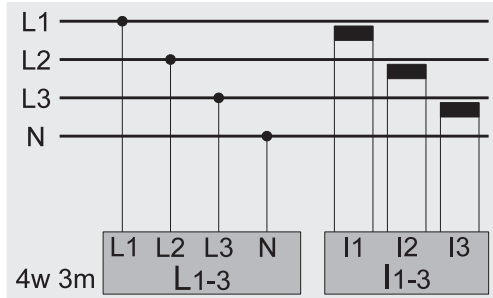

Fig. measurement in a three-phase 4 conductor network with asymmetrical load.

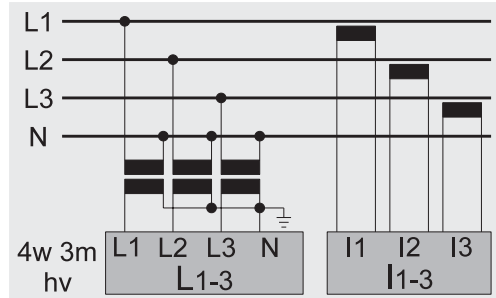

Fig. measurement using 3 voltage converters in a three-phase 4 conductor network with asymmetrical load.

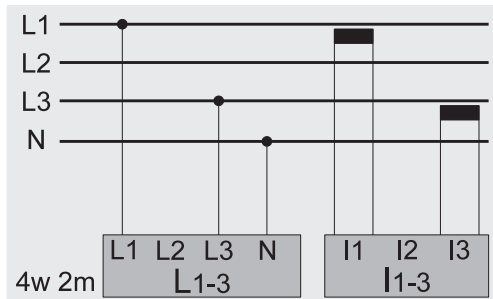

Fig. measurement using a three-phase 4 conductor network with symmetrical load.

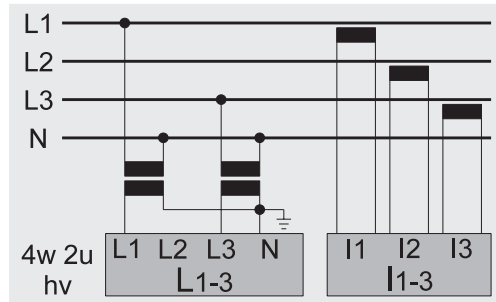

Fig. measurement using 2 voltage converters in a three-phase 4 conductor network with asymmetrical load.

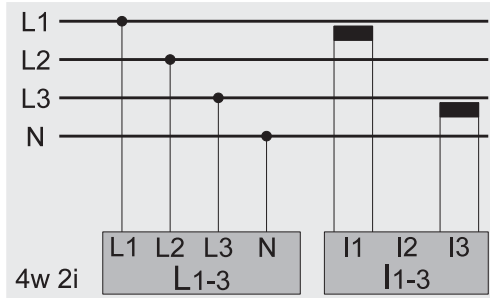

Fig. measurement using 2 current converters in a three-phase 3 conductor network with symmetrical load.

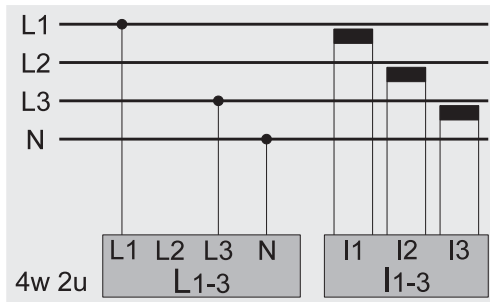

Fig. measurement in a three-phase 4 conductor network with asymmetrical load.

Installation

3-conductor connection

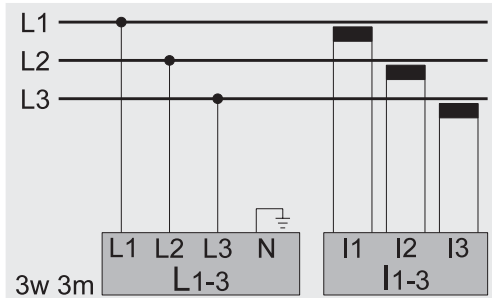

Fig. measurement in a three-phase 3 conductor network with asymmetrical load.

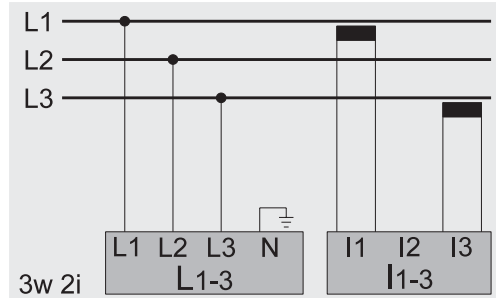

Fig. measurement in a three-phase 3 conductor network with asymmetrical load.

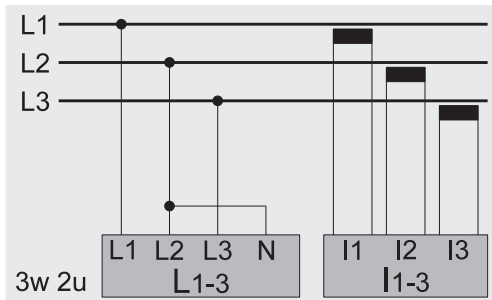

Fig. measurement in a three-phase 3 conductor network with asymmetrical load.

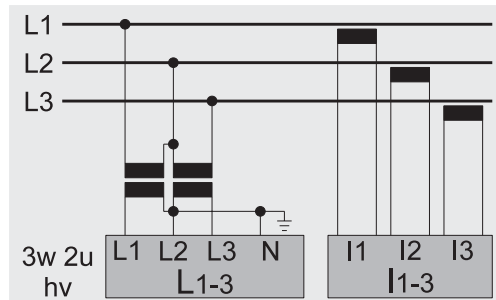

Fig. measurement in a three-phase 3 conductor network with asymmetrical load.

Installation

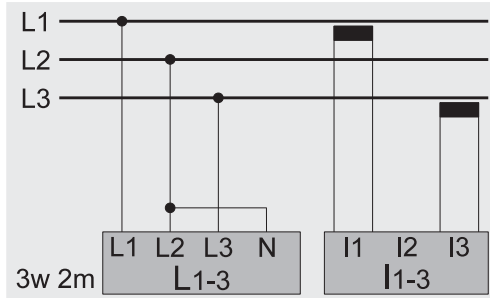

Fig. measurement in a three-phase 3 conductor network with asymmetrical load.

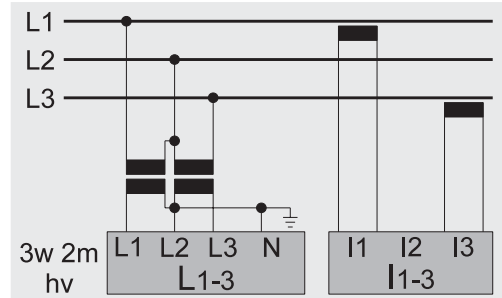

Fig. measurement in a three-phase 3 conductor network with asymmetrical load.

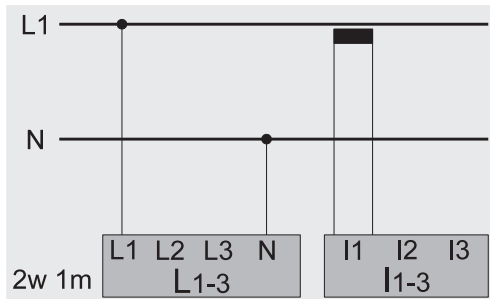

Fig. measurement of a phase in a three-phase 4 conductor network.

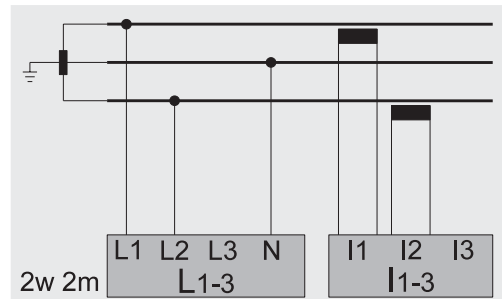

Fig. measurement in a single-phase 3 conductor network. I3 and U3 are not calculated and set to zero.

Auxiliary measurement, input V4

3-conductor connection

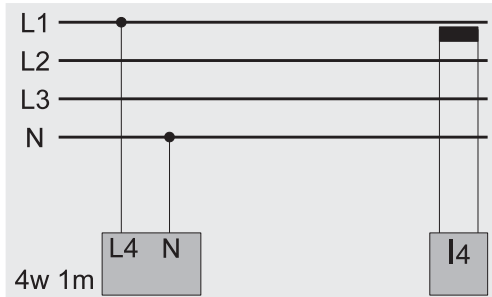

Fig. measurement using a three-phase 4 conductor network with symmetrical load.

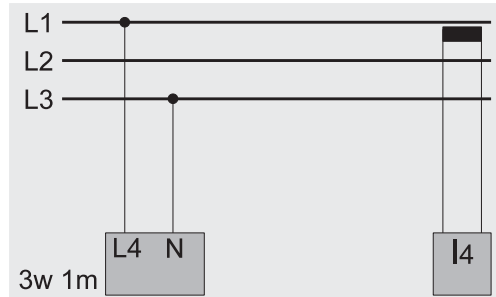

Fig. measurement in a three-phase 3 conductor network with symmetrical load.

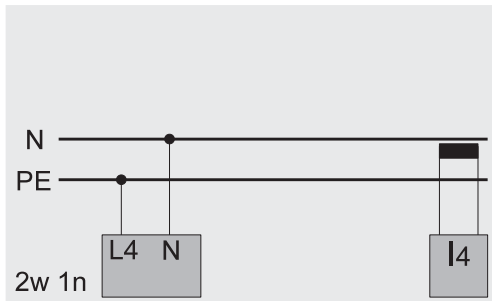

Fig. measurement of the voltage between N and PE. Measurement of the current in the neutral wire.



Be connected for the measurement of the auxiliary measurement (V4) for frequency estimation needs a voltage to the main measurement.



In case of a three wire main measurement (input V1-V3), the auxiliary measurement (input V4) cannot be used as measuring input.

Current measurement

The EM-PQ2200 is designed for the connection of current transformers with secondary currents of $\dots/1A$ and $\dots/5A$. Only alternating currents, not direct currents, can be measured.

Each current measurement input can be permanently loaded with 6A or for 1 second with 100 A.

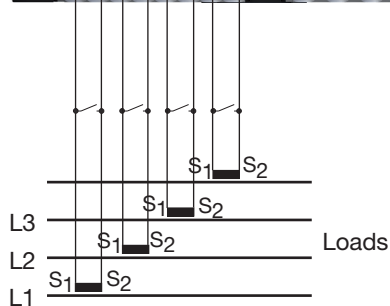

Fig. Connection example, current measurement via current transformers.



Attention!

The current inputs are live.



Important!

The EM-PQ2200 is not suitable for the measurement of direct voltages.



Earthing current transformers

If a connection is provided for earthing the secondary winding, this must be connected with earth.

Installation

When connecting the voltage measurement, the following must be observed:

- In order to disconnect the voltage and current, a suitable circuit breaker is to be provided.
- The circuit breaker must be positioned near to the EM-PQ2200, identified for the user and easy to reach.
- Only use authorised UL/IEC excess current protection devices and circuit breakers.
- Please use a 6A (UL-listed) cable circuit breaker.
- The excess current protection device must have a nominal value which is measured for the short circuit current at the connection point.
- Measurement voltages and measurement currents must come from the same network.



Caution!

Voltages that exceed the permitted nominal network voltages must be connected using a voltage converter.



Caution!

The EM-PQ2200 is not suitable for measuring DC voltages.



Caution!

Contact with the voltage measurement inputs on the EM-PQ2200 is dangerous!



Caution!

The voltage measurement inputs may not be used for voltage measurement in SELV circuits (low voltage protector).

Ammeter

If you not only want to measure the current with the EM-PQ2200 but with an ammeter also, the ammeter must be connected in series to the EM-PQ2200.

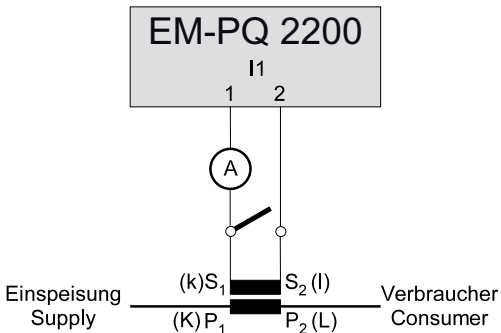

Fig. Example, current measurement via additional ammeter.



Short-circuit current transformer connections!

The secondary connections of the current transformer must be short-circuited to them first before the current supply leads to the EM-PQ2200 are disconnected!

If a testing switch is available, which automatically short circuits the current transformer's secondary leads, it is sufficient to place this in the "test" position, provided the short-circuiters have been tested first.



Open current transformer!

High hazardous live voltage peaks can occur at current transformers which are operated open on the secondary side!

The winding insulation in "safe open current transformers" is dimensioned so that the current transformers can be operated open. But these current transformers are also hazardous live if they are operated open.

Summation current measurement

If the current is measured via two current transformers, the total transformation ratio of the current transformers must be programmed in the EM-PQ2200.

Example

The current is measured via two current transformers. Both current transformers have a transformation ratio of 1000/5A. The summation measurement is performed with a 5+5/5A summation current transformer.

The EM-PQ2200 must then be set as follows:

$$\begin{aligned} \text{Primary current: } & 1000\text{A} + 1000\text{A} = 2000\text{A} \\ \text{Secondary current: } & 5\text{A} \end{aligned}$$

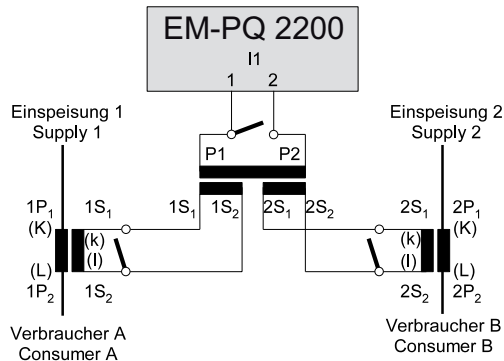

Fig. Example, current measurement via summation current transformers.

Direct measurement

Nominal currents up to 5 A can also be measured directly with the EM-PQ2200. In this case it must be noted that each current measurement input may be loaded continuously with 6 A or for 1 second with max 100 A.

As the EM-PQ2200 does not have any integrated protection for the current measurement, this protection (e.g. 6A fuse type C) must be provided for during installation.

The direction of the current for each phase can be corrected direct at the device or by the provided software.

In case of wrong connections (k – I / S1 – S2) there is no changing of the wiring necessary.

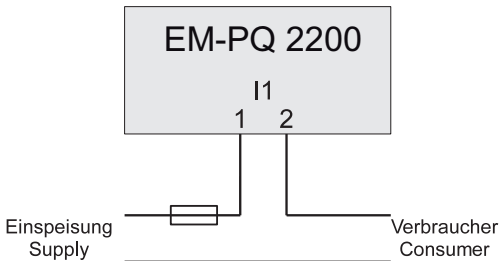

Fig. Example, direct current measurement.



Interfaces

RS232

You can use a RS232 connection cable to connect the EM-PQ2200 to a PC.

The achievable distance between two devices with RS232 interface depends on the cable used and the baud rate. The maximum connectable cable length is 30 m!

As a guideline value, for a transmission rate of 9600 baud the distance should not exceed 15 m to 30 m.

The permissible ohmic load must be larger than 3 kohm and the capacitive load caused by the transmission cable must be smaller than 2500 pF.

Shielding

A twisted-conductor and shielded cable must be provided for connections via the RS232 interface. The shielding at both ends of the cable must be connected to a large area of the housing or cabinet parts in order to achieve an adequate shielding effect.



Important!
Profibus, RS232, RS485 and temperature measurement input are not metallically separated from each other.



All interfaces can be used simultaneously.

Installation

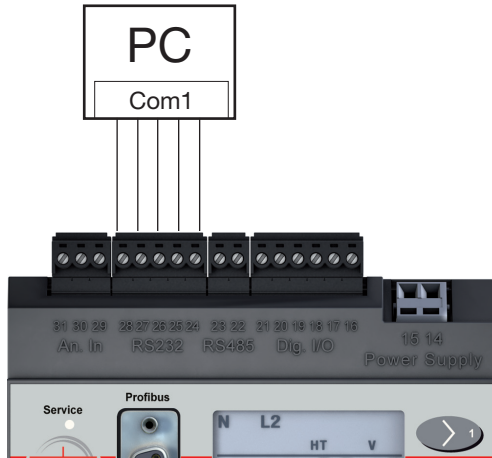

Fig. Example, connecting a EM-PQ2200 to a PC via the RS232 interface.

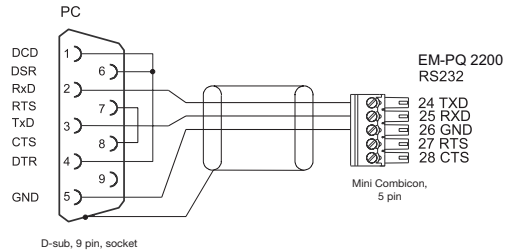

Fig. Connector pin assignment for the PC connection cable.

RS485

Bus structure

All devices are connected in a bus structure (line). Up to 32 stations can be connected together in a segment. The cable at the start and end of a segment is terminated with resistors.

If there are more than 32 stations, repeaters must be used to connect the individual segments.

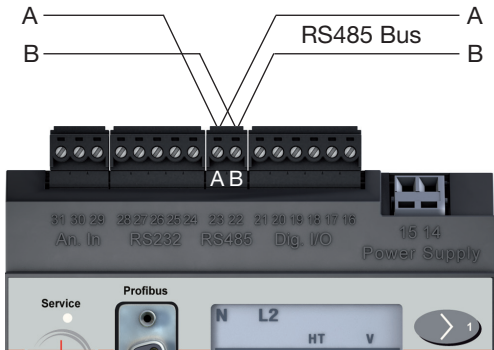

Terminating resistors

The cable at the start and end of a segment is terminated with resistors (120 ohm, 1/4 W).

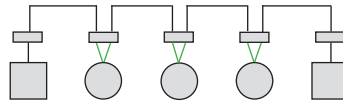

The EM-PQ2200 does not contain any terminating resistors.

Correct

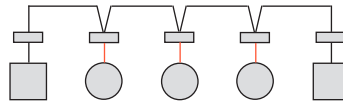

Incorrect



-  Terminal strip in the control cabinet.
-  Device with RS485 interface.
(Without terminating resistor)
-  Device with RS485 interface.
(With terminating resistor at the device)

Shielding

A twisted-conductor and shielded cable must be provided for connections via the RS485 interface. The shielding at both ends of the cable must be connected to a large area of the mounting plate or cabinet parts in order to achieve an adequate shielding effect.

Cable type

Recommended cable types:

Unitronic Li2YCY(TP) 2x2x0.22 (Lapp cables)

Unitronic BUS L2/FIP 1x2x0.64 (Lapp cables)

Cable length

1200 m for a baud rate of 38.4 k



Important!

Profibus, RS232, RS485 and temperature measurement input are not metallically separated from each other.

RS485 profibus DP V0 slave

The profibus connection in the EM-PQ2200 is a 9 pin DSUB socket.

We recommend use of a 9 pin profibus connector for the connection, e.g. as made by Phoenix, type "SUBCON-Plus-ProfIB/AX/SC" with product number 2744380.

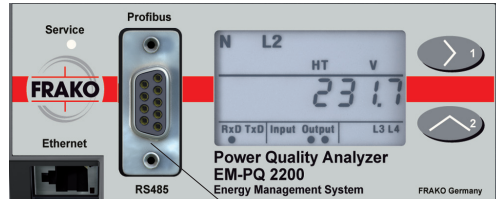

— Profibus connection

Fig. EM-PQ2200 with profibus interface.

Installation

Connecting the bus cables

The incoming bus cable is connected to terminals 1A and 1B. The bus cable for the next device in the line is connected to terminals 2A and 2B. If there is not another device in the line the bus cable must be terminated with resistors (switch set to ON).

In the ON switch setting terminals 2A and 2B are switched off for the continuing bus cable.

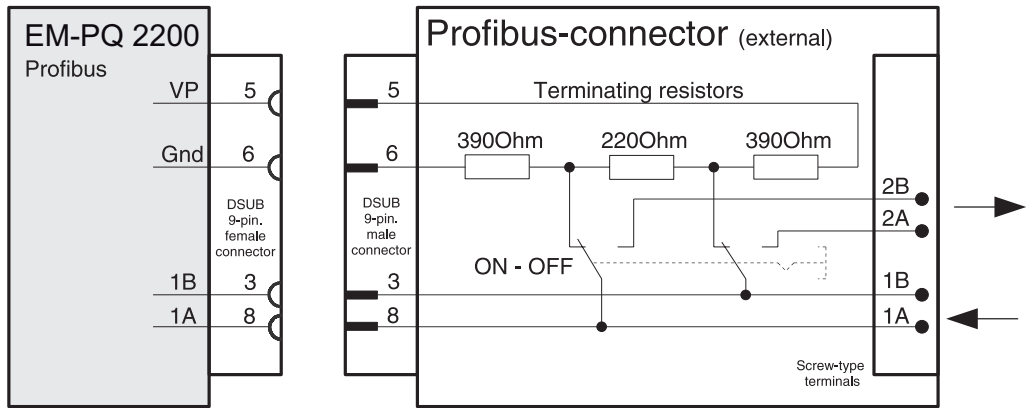

Fig. Profibus connector with terminating resistors.

Digital inputs and outputs

Digital outputs

The EM-PQ2200 has 2 transistor switching outputs. These outputs are metallically separated from the analysis electronics via optocouplers.

- The digital outputs can switch direct or alternating current load.
- The digital outputs can switch loads independent on the polarity of the feeding voltage.
- The digital outputs are not short-circuit-proof.
- Cables, which are longer but 30m must be shielded.

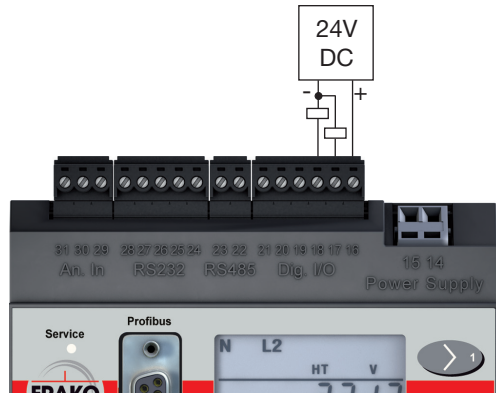

Fig. Connection example.



Attention!
The digital outputs are not short-circuit-proof.

Installation

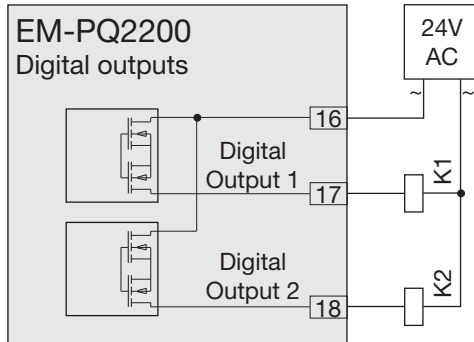

Fig. Connection of alternating voltage relays to the digital outputs.

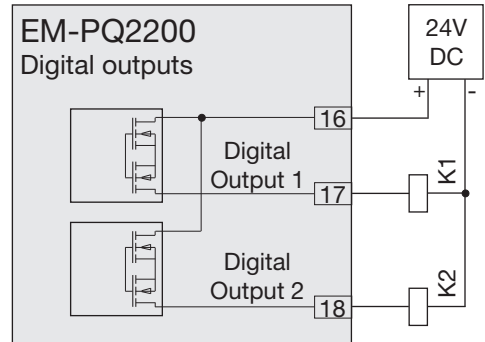

Fig. Connection of direct current relays to the digital outputs.

Installation

Digital inputs

The EM-PQ2200 has 2 digital inputs to each of which you can connect one transducer.

An input signal is detected at a digital input if a voltage of at least 10 V and maximum 28 V is applied. In this case a current of at least 1 mA and maximum 6 mA flows. Cables longer than 30 m must be laid with shielding. Please mind the polarity of the feeding voltage.

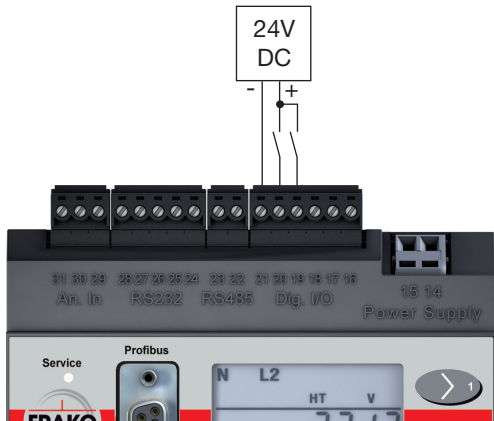

Fig. Connection example.

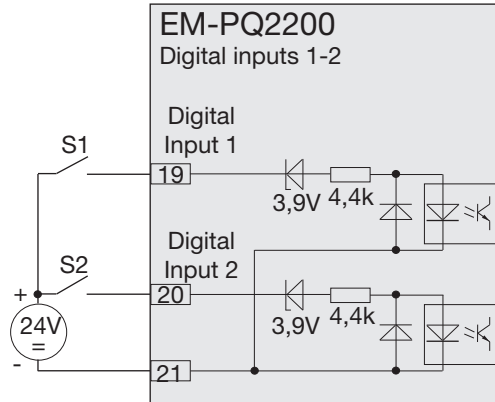

Fig. Example for the connection of external switching contacts S1 and S2 to the digital inputs 1 and 2.



Attention!

The polarity of the feeding voltage must be respected for the digital inputs.

S0 pulse input

At each EM-PQ2200 with inputs for 24 V you can also connect S0 pulse generators according to DIN EN 62053-31.

You require only one external auxiliary voltage of 20..28 V DC and one external 1.5 kohm resistor each.

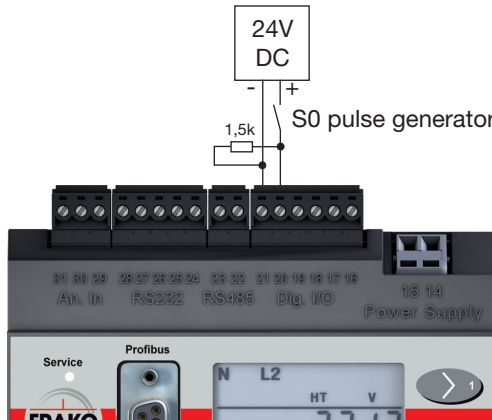

Fig. EM-PQ2200 with inputs for 24 V. Example with S0 pulse generator.

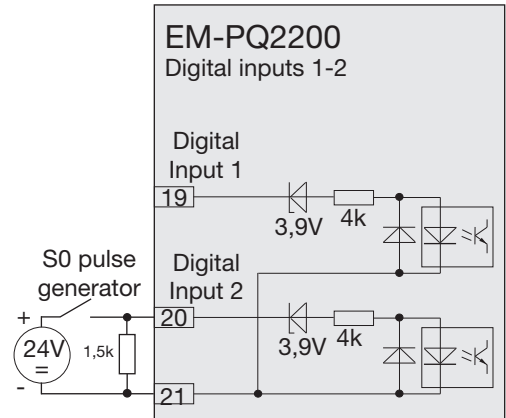

Fig. EM-PQ2200 with inputs for 24 V. Example for connection of an S0 pulse generator at digital input 2.

Temperature measurement input

Temperature sensors with a resistance range of 400 ohm to 4 kohm can be connected to the temperature measurement input.

The total burden (sensor + cable) of 4 kohm may not be exceeded.

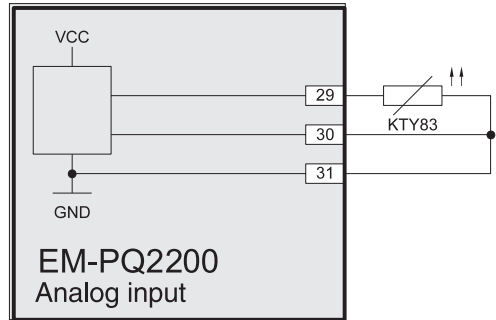
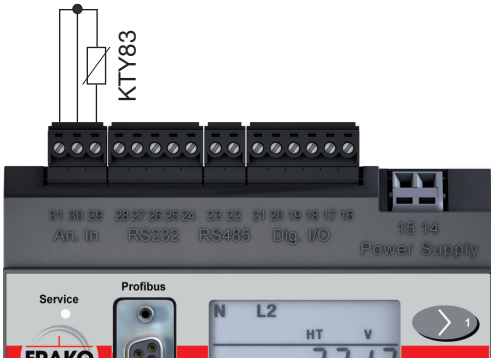

Fig. Example, temperature measurement with a KTY83.



Use a shielded cable to connect the temperature sensor.



Important!
Profibus, RS232, RS485 and temperature measurement input are not metallically separated from each other.



Operation

The EM-PQ2200 has a display, keys 1 and 2 and the Service key to make it easier to install and start up the EM-PQ2200 without a PC.

Important parameters such as current transformers and device address are included in the parameter list (see Appendix) and can be directly programmed at the device.

A differentiation is made between operation with the

- display mode and
- Programming mode.

Key functions

Press the key “briefly”:

- page forwards
- Digit/value +1

Press the key for “long time”:

- page backwards
- Digit/value -1

Simultaneously press both keys for around 1 second and keep them pressed:

- Switch between display mode and programming mode.

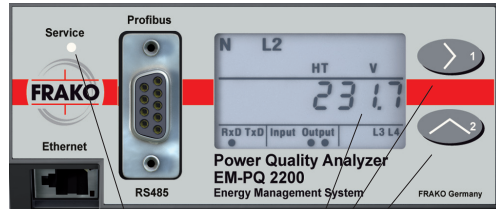

Display
Key 1
Key 2
Concealed key

Keys 1 and 2



The EM-PQ2200 is operated using keys 1 and 2.

Concealed key (service)

The Service key is intended for use by instructed service employees only.

Display mode

After the power supply is resumed the device is in Display mode.

In Display mode you can use Keys 1 and 2 to page between the measured value displays.



Use Key 1 to select the phase for the measured values.



Press Key 2 to page between the measured values for current, voltage, power output, etc.

The factory default setting for the measured value displays is shown in the “measured value displays” in the Appendix.



Important!

The user can use the EM-PQ VIS/Jasic to reconfigure the function of the keys and selection of the values to be displayed.

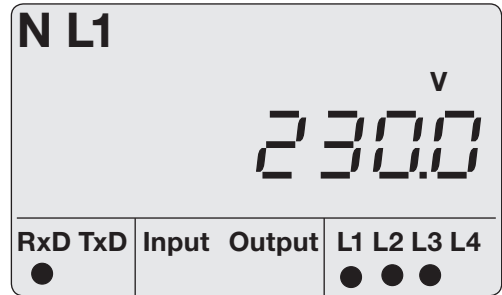

Fig. “Display Mode” display example.
Displayed measured value: $U_{L1-N} = 230.0 V$.

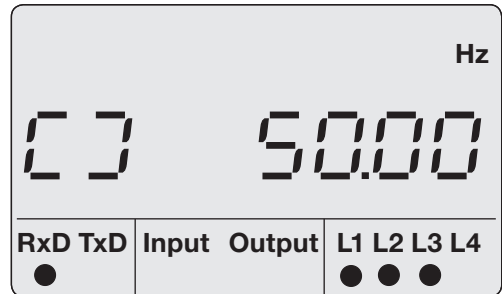

Fig. Display example for rotating field and frequency.

Programming mode

The most important settings required for operation of the EM-PQ2200 can be displayed and changed in programming mode.

The parameter list in the Appendix contains the addresses for the most important settings. You can make further settings using the EM-PQ VIS software included in the scope of supply.

If you simultaneously press Keys 1 and 2 for around 1 second, programming mode opens via a password query. If a display password has not been programmed, the first programming menu opens directly. Programming mode is denoted in the display by the text “PRG”. The digits of the address flash.

If you are in programming mode and have not pressed a key for approximately 60 seconds or simultaneously press Keys 1 and 2 for around 1 second, the device returns to display mode.

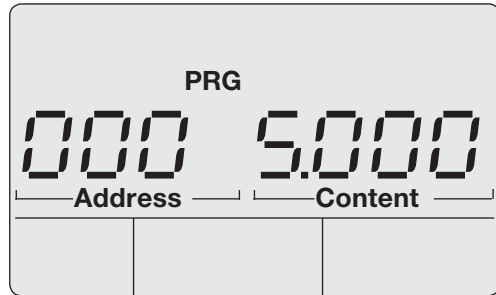

Fig. “Programming Mode” display example, address 000 with content 5,000.

Display password

You can program a 4-digit display password to make it difficult to accidentally change the programming data directly at the device. A display password is not set in the factory.

Homepage password

You can protect access to the EM-PQ2200's homepage via a password. A homepage password is not set in the factory.

Password mode

The EM-PQ2200 differentiates between 3 password modes for the homepage password:

- 0 = The homepage password is not queried.
- 2 = Changes to the configuration and the display of measured values require the password to be entered once.
- 128 = Each change to the configuration requires renewed input of the password.

Forgot password?

After a safe connection between the EM-PQ2200 and EM-PQ VIS please clear the password via software.

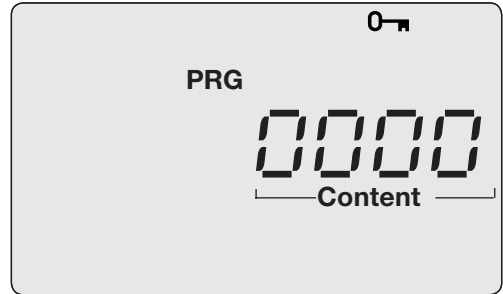

Fig. Query window for the display password.

Addr.	Content
500	Display password 0 =the password is not queried.
501	Homepage, password mode
502	Homepage password

Fig. Section of the parameter list for password programming.

Measurements

The EM-PQ2200 has four measuring channels for the voltage measurement (V1...V4 against Vref) and four measuring channels for the current measurement (I1...I4). The Voltage and current to be measured have to be come out of the same grid.

Main measurements (channels 1 – 3)

For the main measurement are the channels 1 – 3 available. Use the measuring channels 1 – 3 for measurements in a three phase system.

For the main measurements are 14 different measurement connections available. The appropriated connection diagrams you will find on page 22-24.

The selected connection has to be adjusted at the parameter "110".

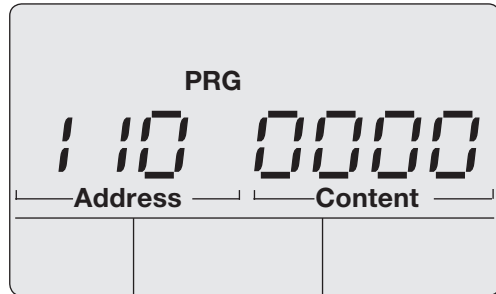

Fig. example of the display; connection for the main measurement, address 110 with the content 0000 (=4w3M).

Selection of connections:

- 0 = 4w3m (default factory setting)
- 1 = 4w2m
- 2 = 4w2u
- 3 = 4w2i
- 4 = 3w3m
- 5 = 3w2m
- 6 = 3w2u
- 7 = 3w2i
- 8 = 2w2m
- 9 = 2w1m
- 10 = 4w3m
- 11 = 4w2m
- 12 = 3w2u
- 13 = 3w2

Auxiliary measurement (channel 4)

For the auxiliary measurement is only the 4th channel available.

Use the measuring channel 4 only in a single phase system or in three phase systems with symmetrical load.

The settings for the frequency and the relevant voltage are adjusted automatically according the settings of the main measurement.

For the auxiliary measurement are 3 different measurement connections available. The appropriated connection diagrams you will find on page 23.

The selected connection has to be adjusted at the parameter “111”.



Fig. example of the display; connection for the auxiliary measurement, address 111 with the content 0000 (=2w1n).

Selection of connections:

- 0 = 2w1n (default factory setting)
- 1 = 3w1m
- 2 = 4w1m

Voltage transformer ratio

The parametrisation of the voltage transformer ratio for the main measurement are under address 002 and 003.

The parametrisation of the voltage transformer ratio for the auxiliary measurement are under address 012 and 013.

A voltage transformer ratio of 400 V/400 V direct measurement is programmed in the factory for all 4 voltage transformer inputs.

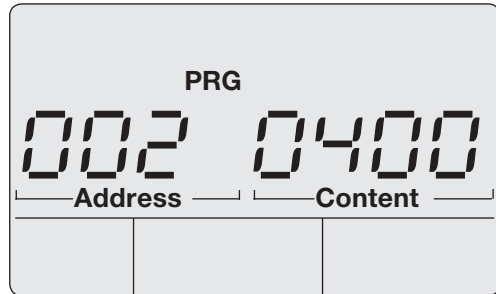

Fig. Example; Voltage transformer (primary) for the main measurement, address 002, content „400“.

Address	Voltage transformer values
002	Main Input
003	L1 L2 L3 (primary)
	L1 L2 L3 (secondary)
012	Auxiliary Input
013	L4 (primary)
	L4 (secondary)

Fig. Section of the parameter list for the voltage transformer values.

Current transformer ratio

The parametrisation of the current transformer ratio for the main measurement are under address 000 and 001.

The parametrisation of the current transformer ratio for the auxiliary measurement are under address 010 and 011.

A current transformer ratio of 5 A/5 A is programmed in the factory for all 4 current transformer inputs.

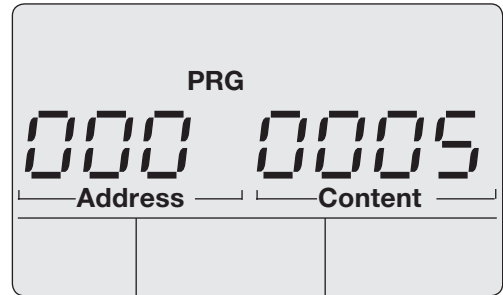

Fig. Example; Current transformer (primary) for the main measurement, address 000, content „0005“.

Address	Current transformer values
000	Main Input
001	L1 L2 L3 (primary)
	L1 L2 L3 (secondary)
010	Auxiliary Input
011	L4 (primary)
	L4 (secondary)

Fig. Section of the parameter list for the current transformer values.

Interfaces

The EM-PQ2200 has 4 serial interfaces:

- RS485
- RS232
- Ethernet
- Profibus

All interfaces can be used simultaneously.

RS232

The following data must be programmed for use of the RS232 interface:

- Baud rate,
- Operating mode.

Refer to the parameter list in the Appendix for the default factory setting and the setting ranges.

RS485

The following data must be programmed for use of the RS485 interface:

- Device address,
- Baud rate,
- Operating mode.

Refer to the parameter list in the Appendix for the default factory setting and the setting ranges.

Addr.	Content
200	Device address (1 .. 255) valid for Modbus and Profibus 1 = default factory setting

Ethernet

Fixed IP address

In simple networks without DHCP servers the network address must be set directly at the device.

BootP

BootP allows fully automatic integration of a EM-PQ2200 in an existing network. BootP is an older protocol and does not have the functional scope of DHCP.

DHCP mode

DHCP enables fully automatic integration of a EM-PQ2200 in an existing network without any further configuration. On starting the EM-PQ2200 automatically imports the IP address, the net mask and the gateway from the DHCP server.

The EM-PQ2200 is set in the factory to “DHCP”.

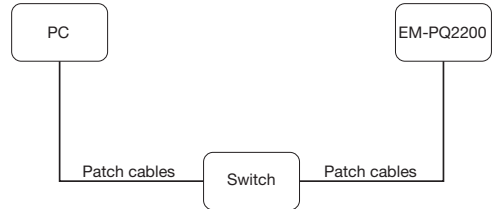

Fig. Connection example, the EM-PQ2200 and PC require a fixed IP address.

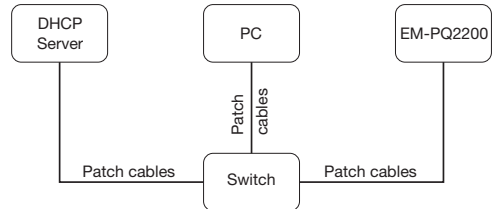

Fig. Connection example, the EM-PQ2200 and PC are automatically assigned an IP address by a DHCP server.



The EM-PQ2200 may only be connected to the ethernet following consultation with the network administrator!

Profibus

Profibus profiles

The EM-PQ2200 can manage 16 profibus profiles. Each profibus profile contains 128 data bytes maximum.

The first data byte of the output area of the PLC (programmable logic controller) always contains the profile number of the profibus profile required by the EM-PQ2200.

To request a profibus profile, write the profile number in the first byte of the output area of the PLC.

All system variables and global variables¹⁾ can be individually scaled and converted into one of the following formats:

- 8, 16, 32 bit integer with and without sign.
- 32 or 64 bit float format.
- Big or little Endian²⁾.

¹⁾Global variables are variables which are defined by the user in Jasic and are available to each interface in the EM-PQ2200.

²⁾ Big-Endian = High byte before low byte
Little-Endian = Low byte before high byte.

Device master file GSD

The device master file for the EM-PQ2200 is called "0B41.GSD" and is included on the CD which belongs to the scope of supply.

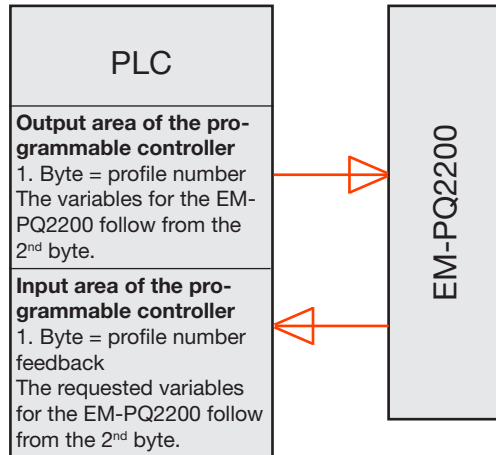

Fig. Block diagram for data exchange between PLC and EM-PQ2200.

Addr.	Content
200	Device address (1 .. 255) valid for Modbus and Profibus 1 = default factory setting

Recordings

2 recordings are preconfigured in the default factory setting of the EM-PQ2200. Recordings are adjusted and extended via “EM-PQ VIS”.

Recording 1

The following measured values are recorded with the time base of 15 minutes:

Voltage L1-N
Voltage L2-N
Voltage L3-N
Voltage L4-N
Current L1
Current L2
Current L3
Current L4
Active power demand L1
Active power demand L2
Active power demand L3
Active power demand L4

(The mean value, minimum value and maximum value are also recorded for each measured value.)

Recording 2

The following measured values are recorded with the time base of 1 hour:

Active power demand L1
Active power demand L2
Active power demand L3
Active power demand L4
Reactive power demand L1
Reactive power demand L2
Reactive power demand L3
Reactive power demand L4

Putting into Service

Applying the power supply voltage

The power supply voltage level for the EM-PQ2200 is given on the rating plate. Supply voltages which do not correspond to those given on the rating plate can result in malfunctions and destruction of the device.

After applying the power supply voltage the text “Start up” appears in the display. Around two seconds later the EM-PQ2200 switches to the first measured value display.

If no display appears, check whether the power supply voltage is within the rated voltage range.

Frequency measurement

For the frequency measurement, the measured voltage must be greater than 10 V in the voltage measuring path L1-N.

Only detected frequencies within the range 15 Hz to 440 Hz are used for measurement at the current and voltage measurement inputs.

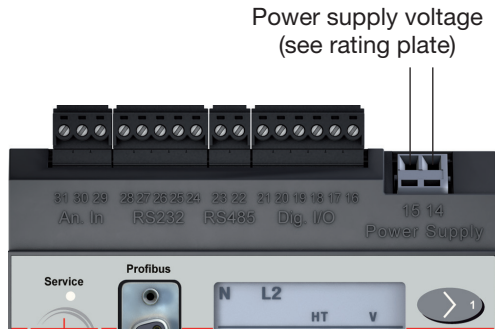

Applying the measuring-circuit voltage

The EM-PQ2200 is suitable for the measurement of voltages of up to 300 V AC to earth and 520 V AC conductor to conductor. The EM-PQ2200 is not suitable for the measurement of direct voltages. Voltages above 300 VAC to earth must be connected via voltage transformers.

After connecting the measurement-current voltages, the measured values displayed by the EM-PQ2200 for the L-N and L-L voltages must correspond to those at the voltage measurement input.

If a voltage transformer factor is programmed, this must be taken into account in the comparison.

Minimum voltage

A measuring-circuit voltage greater than $10V_{eff}$ must be applied to the voltage measurement input V1. If an adequately high measuring-circuit voltage is not applied the EM-PQ2200 cannot determine the system frequency and can therefore also not take a measurement.

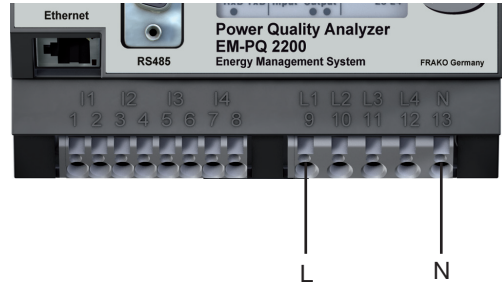

At least one phase (L) and the neutral conductor (N) must be connected to the voltage measurement input for the measurement.

Phase sequence

Check the direction of the voltage rotating field in the measured value display of the EM-PQ2200.

A “right” rotating field usually exists.

Applying the measuring-circuit current

The EM-PQ2200 is designed for the connection of $\dots/1A$ and $\dots/5A$ current transformers.

Only alternating currents, not direct currents, can be measured via the current measurement inputs.

Short-circuit all current transformer outputs except one. Compare the currents displayed by the EM-PQ2200 with the applied current.

Taking into account the current transformer transformation ratio, the current displayed by the EM-PQ2200 must correspond to the input current.

The EM-PQ2200 must display approximately zero Amperes in the short-circuited current measurement inputs.

The current transformer ratio is set to $5/5A$ in the factory and if necessary must be adapted to the current transformer used.

Checking the energy measurement

Short-circuit all current transformer outputs except for one and check the displayed power outputs.

The EM-PQ2200 may only display one power output in the phase with a non short-circuited current transformer input. If this is not the case, check the connection of the measuring-circuit voltage and the measuring-circuit current.

If the power output amount is correct but the sign of the power output is negative, S1(k) and S2(l) could be inverted at the current transformer or they supply active energy back into the network.

System information

Overrange

Overranges are displayed as long as they exist and cannot be acknowledged. An overrange exists if at least one of the four voltage or current measurement inputs lies outside their specified measuring range.

If an overrange exists it is shown in the display with “EEEE”.

The symbols L1, L2, L3 and L4 are used to indicate at which input the overrange has occurred. The “V” and “A” symbols indicate whether the overrange occurred in the current or in the voltage path.

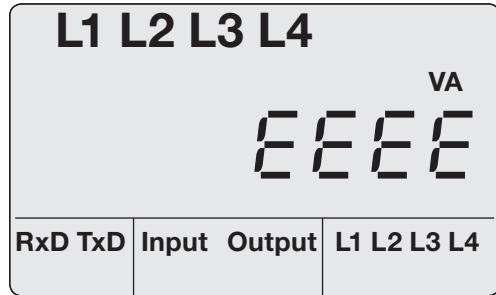

Fig. Measured value display with overrange.



Important!

Voltages and currents that lie outside the permissible measuring range can destroy the device.

Serial number

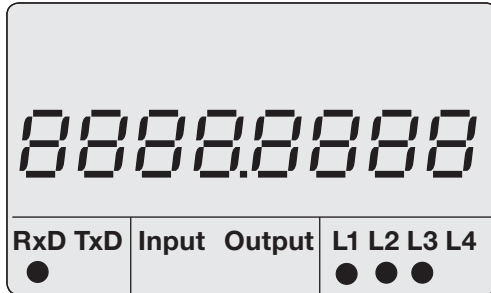

Fig. Measured value display with serial number.

Firmware release

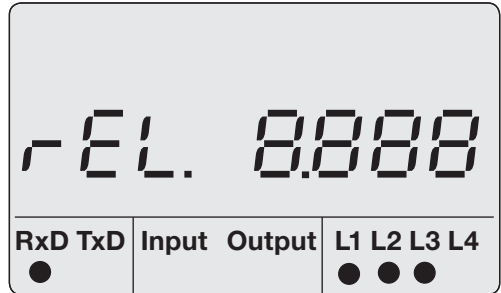

Fig. Measured value display for the firmware release.

Date

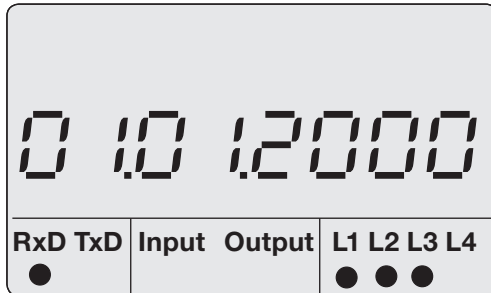

Fig. Measured value display with date.

Time

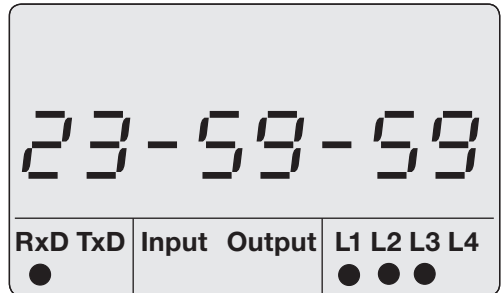

Fig. Measured value display with time.

Service and maintenance

The device is subjected to various safety checks before delivery and marked with a seal. If a device is opened, the safety checks must be repeated. A warranty will be provided for unopened devices only.

Repair and calibration

Repair work and calibration can be carried out by the manufacturer only.

Front film

The front film can be cleaned with a soft cloth and standard household cleaning agent. Do not use acids and products containing acid for cleaning.

Battery

The internal clock is provided with power from the power supply voltage. If the power supply voltage fails the clock is supplied by the battery. The clock supplies date and time information, e.g. for recordings, minimum and maximum values and events.

The life expectancy of the battery is at least 5 years, at a storage temperature of +45°C. The typical life expectancy of the battery is 8 to 10 years.

The device must be opened to change the battery. If the device has been opened a renewed safety check is necessary for safe operation. A warranty will be provided for unopened devices only.

Disposal

The EM-PQ2200 can be reused or recycled as electronic scrap in accordance with the legal provisions. The permanently installed lithium battery must be disposed of separately.

Firmware update

If a firmware update has to be performed for your EM-PQ2200 you can do this with the EM-PQ VIS software included in the scope of supply.

Service

Should questions arise, which are not described in this manual, please contact the manufacturer directly.

We will need the following information from you to answer any questions:

- Device name (see rating plate),
- Serial name (see rating plate),
- Software release (see measured value display),
- Measuring-circuit voltage and power supply voltage,
- Precise description of the error.

Service and maintenance

Trouble shooting

Possible error	Cause	Remedy
No display .	External fusing for the power supply voltage has tripped.	Replace fuse.
	Device is defective.	Send device to the manufacturer for repair.
No current display .	Measurement voltage is not connected.	Connect the measuring-circuit voltage.
	Measurement current is not connected.	Connect measuring-circuit current.
Displayed current is too large or too small.	Current measurement in the wrong phase. Current transformer factor is incorrectly programmed.	Check connection and correct if necessary. Read out and program the current transformer transformation ratio at the current transformer.
“EEEE” and “A” in the display.	The current measuring range has been exceeded.	Check the measuring-circuit current and if necessary install a suitable current transformer.

Service and maintenance

Possible error	Cause	Remedy
Displayed voltage is too small or too large.	Measurement in the wrong phase. Voltage transformer incorrectly programmed.	Check connection and correct if necessary. Read out and program the voltage transformer transformation ratio at the voltage transformer.
Displayed voltage is too small.	Overrange. The peak voltage value at the measurement input has been exceeded by harmonic components.	Install voltage transformers. Important! Ensure the measurement inputs are not overloaded.
“EEEE” and “V” in the display.	The voltage measuring range has been exceeded.	Check the measuring-circuit voltage and if necessary install a suitable voltage transformer.
„Error CF„ in the display	The calibration data could not be read out.	Send device to the manufacturer for checking with a precise description of the error.

Service and maintenance

Possible error	Cause	Remedy
Active power too small or too large.	The programmed current transformer transformation ratio is incorrect. The current path is assigned to the wrong voltage path. The programmed voltage transformer transformation ratio is incorrect.	Read out and program the current transformer transformation ratio at the current transformer. Check connection and correct if necessary. Read out and program the voltage transformer transformation ratio at the voltage transformer.
Active power consumption / supply is reversed.	At least one current transformer connection is mixed up/reversed. A current path is assigned to the wrong voltage path.	Check connection and correct if necessary. Check connection and correct if necessary.
No connection with the device.	RS485: - Device address is incorrect. - Wrong protocol. - Termination missing. Ethernet: - IP address incorrect - The concealed key (service) was used.	Adjust the device address. Select protocol. Close bus with terminating resistor (120 ohm). Adjust IP address at the device. Overwriting the address 204 with 0 and set IP address or select DHCP.

Possible error	Cause	Remedy
Despite the measures above the device does not work.	Device is defective.	Send device to the manufacturer for checking with a precise description of the error.

Technical specifications

General information

Net weight	: 350g
Device dimensions	: approx l=107.5 mm, b=90 mm, h=82 mm (according to DIN 43871:1992)
Housing flammability class	: UL94V-0
Installed position	: any
Fixing/mounting	: 35 mm top hat rail (according to IEC/EN 60999-1, DIN EN 50022)
Battery	: Type lithium CR2032, 3 V

Ambient conditions during operation

The EM-PQ2200 is intended for weather-protected, stationary use. The EM-PQ2200 fulfils the use conditions according to DIN IEC 60721-3-3.

Operating temperature range	: -10°C. +55°C
Relative humidity	: 5 to 95 %, (at +25 °C) without condensation
Degree of pollution	: 2
Operating altitude	: 0 .. 2000 m above sea level
Installed position	: any
Ventilation	: Forced ventilation is not required.

Transport and storage

The following information applies to devices which are transported or stored in the original packaging.

Free fall	: 1m
Temperature	: -20°C to +70°C

Power supply voltage

The power supply voltage must be connected to the EM-PQ2200

via a UL listed fuse : 6A, type C (approved to UL / IEC)

Overvoltage category : 300 V CATIII

230V

Nominal range : 95V .. 240V (45-65 Hz) or DC 135V .. 340V

Operating range : +/-10% of nominal range

Connectable conductors

Only one conductor may be connected per terminal connection!

Solid core, multi-core, flexible core : 0.08 - 2,5 mm², AWG 28 - 12

Pin-end connector, wire end ferrules : 1.5 mm², AWG 16

Power consumption : max 3.2W, max 9VA

Protection class

Class II according to IEC 60536 (VDE 0106, Part 1), i.e. a PE terminal is not required!

Protection against ingress of solid foreign
bodies and water

: IP20 according to EN 60529 September 2000,
IEC 60529:1989

Inputs and outputs

2 digital inputs

Pulse input (S0)

Maximum counting frequency : 20 Hz

Switching input

Response time (Jasic program) : 200 ms

Input signal applied : 18V. 28 V DC (typically 4 mA)

Input signal not applied : 0 .. 5 V DC, current less than 0.5 mA

2 digital outputs, semi-conductor relay, not short-circuit proof.

Switching voltage : max 60 V DC, 30 V AC

Switching current : max 50 mAeff AC/DC

Response time (Jasic program) : 200 ms

Output of voltage dips : 20 ms

Output of voltage overranges : 20 ms

Pulse output (operating pulses) : max 20 Hz

Cable length : up to 30 m unshielded
: greater than 30m shielded

Connectable conductors

Solid core, multi-core, flexible core : 0.08 - 1.5 mm²

Pin-end connector, wire end ferrules : 1 mm², only one conductor may connected per terminal connection!

Technical specifications

Temperature measurement input

Update time : approx 200 ms
Connectable sensors : PT100, PT1000, KTY83, KTY84
Total burden (sensor + cable) : max 4 kohm

Sensor type	Temperature range	Resistance range	Measurement uncertainty
KTY83	-55 ° .. +175 °C	500 ohm .. 2.6 kohm	± 1.5% rng
KTY84	-40 ° .. +300 °C	350 ohm .. 2.6 kohm	± 1.5% rng
PT100	-99 ° .. +500 °C	60 ohm .. 180 ohm	± 1.5% rng
PT1000	-99 ° .. +500 °C	600 ohm .. 1,8 kohm	± 1.5% rng

rng = measuring range

Cable length : up to 30 m unshielded
: greater than 30 m shielded

Connectable conductors : 0.08 - 1.5 mm²
Solid core, multi-core, flexible core : 1 mm², only one conductor may be connected per terminal connection!
Pin-end connector, wire end ferrules

Technical specifications

Interfaces

RS232		: 5 pin screw-type terminals.
Protocol		: Modbus RTU/slave
Transfer rate		9600 bps, 19.2 kbps, 38.4 kbps, 115.2 kbps
RS485		: 2 pin screw-type terminals.
Protocol, modbus RTU		: Modbus RTU/slave, modbus RTU/master
Transfer rate		: 9.6 kbps, 19.2 kbps, 38.4 kbps, 57.6 kbps, 115.2 kbps, 921.6 kbps
RS485		: Connector, SUB D 9 pin
Protocol, profibus		: Profibus DP/V0 according to EN 50170
Transfer rate		: 9.6 kbaud up to 12 Mbaud
Ethernet 10/100Base-TX		
Connection		: RJ-45
Functions		: Modbus gateway, embedded web server (HTTP)
Protocols		: TCP/IP, EMAIL (SMTP), DHCP (BootP), Modbus/TCP (Port 502), ICMP (Ping), Modbus RTU over ethernet (Port 8000), FTP, NTP, TFTP.

Measurement uncertainty

The measurement uncertainty of the EM-PQ2200 applies to use of the following measuring ranges. The measured value must lie within the given limits. Outside these limits the measurement uncertainty is unspecified.

Measured value	Measurement uncertainties
Voltage	± 0.2% DIN EN 61557-12:2008
Current L	± 0.2% DIN EN 61557-12:2008
Current N	± 0.6% DIN EN 61557-12:2008
Power	± 0.4% DIN EN 61557-12:2008
Harmonic components U, I	Class 1 DIN EN 61000-4-7
Active energy	
Current transformer ../5A	Class 0.5S (DIN EN 62053-22:2003, IEC 62053:22:2003)
Current transformer ../1A	Class 1 (DIN EN 62053-21:2003, IEC 62053:21:2003)
Reactive energy	
Current transformer ../5A	Class 2 (DIN EN 62053-23:2003, IEC 62053:23:2003)
Current transformer ../1A	Class 2 (DIN EN 62053-23:2003, IEC 62053:23:2003)
Frequency	± 0.01Hz
Internal clock	±1 minute/month (18°C ... 28 °C)

The specifications apply under the following conditions:

- Annual recalibration,
- a warming up time of 10 minutes,
- an ambient temperature of 18 .. 28°C.

If the device is operated outside the range from 18 .. 28°C an additional measurement error equal to ±0.01% of the measured value must be taken into account per °C difference.

Measuring inputs

Voltage measurement

Three-phase 4-wire systems (L-N/L-L)	: max. 277 V/480 V
Three-phase 3-wire systems (L-L)	: max. 480 V
Resolution	: 0,01 V
Crest-faktor	: 2 (referring to 480 Vrms)
Measurement category	: 300V CAT III
Specified impulse withstand voltage	: 4 kV
Impedance	: 4 MOhm/phase
Power input	: approx 0.1 VA
Scanning frequency	: 20 kHz/phase
Transients	: >50 µs
Fundamental oscillation	: 15 Hz .. 440 Hz
Resolution	: 0,001 Hz

Connectable conductors (current measurement and voltage measurement)

Only one conductor may connected per terminal connection.

Solid core, multi-core, flexible core : 0.08 - 4 mm², AWG 28 - 12

Pin-end connector, wire end ferrules : 2.5 mm², AWG 14

Current measurement

Nominal current	: 5 A
Rated current	: 6 A
Resolution	: 1mA
Crest-faktor	: 2 (referring to 6 Arms)
Measurement category	: 300 V CAT III
Specified impulse withstand voltage	: 4 kV
Power input	: approx 0.2 VA (Ri=5 mohm)
Overload for 1 sec	: 100 A (sinusoidal)
Scanning frequency	: 20 kHz

Appendix

Parameter list

Add	Format	Name	Setting range	Units	Default setting
000	float	Current transformer, primary, L1..L3	0 .. 1000000	A	5
001	float	Current transformer, secondary, L1..L3	1 .. 5	A	5
002	float	Voltage transformer, primary, L1..L3	0 .. 1000000	V	400
003	float	Voltage transformer, secondary, L1..L3	1 .. 400	V	400
010	float	Current transformer, primary, L4	0 .. 1000000	A	5
011	float	Current transformer, secondary, L4	1 .. 5	A	5
012	float	Voltage transformer, primary, L4	0 .. 1000000	V	400
013	float	Voltage transformer, secondary, L4	1 .. 400	V	400

Appendix

Add	Format	Name	Setting range	Units	Default setting
100	int	Automatically get TFTP configuration file 0 = switched off x = file number	0 .. 9999	-	0
101	int	TFTP error handling 0 = In the event of an error the Configuration menu appears in the EM-PQ2200. 1 = In the event of an error the does NOT switch to the Configuration menu of the EM-PQ2200.	0 .. 1	-	0
110	short	Current transformer circuit (L1 .. L3) 0=4w3m, 1=4w2m, 2=4w2u, 3=4w2i, 4=3w3m, 5=3w2m, 6=3w2u, 7=3w2i, 8=2w2m, 9=2w1m, 10=4w3m, 11=4w2m, 12=3w2u, 13=3w2m)	0 .. 13	-	0
111	short	Voltage measurement system configuration 0=2w1n, 1=3w1m, 2=4w1m	0 .. 2	-	0
112	short	Relevant voltage 0 = L-N, 1 = L-L	0 .. 9	-	0
113	short	Deletes all real and apparent energy meters and S0-counters (1 = delete)	0 .. 1	-	0
114	short	Deletes all reactive energy meters (1 = delete)	0 .. 1	-	0
115	short	Resets all minimum and maximum values (1 = reset)	0 .. 1	-	0
116	short	Flickerfilter 0 - 50Hz/230V, 1 - 120V/50Hz 2 - 230V/60Hz, 3 - 120V/60Hz	0 .. 3	-	0

Appendix

Add	Format	Name	Setting range	Units	Default setting
200	int	Device address, modbus/profibus	1 .. 255	-	1
201	int	Baud rate, RS232 0 = 9600 bit/s 1 = 19200 bit/s 2 = 38400 bit/s 3 = 57600 bit/s 4 = 115200 bit/s	0 .. 4	-	4
202	int	Baud rate, RS485 0 = 9600 bit/s 1 = 19200 bit/s 2 = 38400 bit/s 3 = 57600 bit/s 4 = 115200 bit/s 5 = 921600 bit/s	0 .. 5	-	4
203	int	RS485, mode 0 = modbus RTU/slave 1 = modbus RTU/master 2 = gateway transparent 3,4 = internal use 5 = BACnet MS/TP (option)	0 .. 5	-	0
204	int	RS232, mode 0 = modbus RTU/slave 3 = Debug 6 = SLIP	0 .. 6	-	0

Appendix

Add	Format	Name	Setting range	Units	Default setting
205	int	DHCP mode 0 = fixed IP 1 = BootP 2 = DHCP-Client	0, 1, 2, 3	-	2
300	int	IP address, xxx --- --- ---	0 .. 255	-	000
301	int	IP address, --- xxx --- ---	0 .. 255	-	000
302	int	IP address, --- --- xxx ---	0 .. 255	-	000
303	int	IP address, --- --- --- xxx	0 .. 255	-	000
304	int	IP mask, xxx --- --- ---	0 .. 255	-	000
305	int	IP mask, --- xxx --- ---	0 .. 255	-	000
306	int	IP mask, --- --- xxx ---	0 .. 255	-	000
307	int	IP mask, --- --- --- xxx	0 .. 255	-	000
310	int	IP gateway, xxx --- --- ---	0 .. 255	-	000
311	int	IP gateway, --- xxx --- ---	0 .. 255	-	000
312	int	IP gateway, --- --- xxx ---	0 .. 255	-	000
313	int	IP gateway, --- --- --- xxx	0 .. 255	-	000

Appendix

Add	Format	Name	Setting range	Units	Default setting
400	short	Day	1 .. 31	-	xx
401	short	Month	1 .. 12	-	xx
402	short	Year	1 .. 9999	-	xxxx
403	short	Hour	0 .. 23	-	xx
404	short	Minute	0 .. 59	-	xx
405	short	Second	0 .. 59	-	xx
406	short	Accept date and time 1 = accept set data	0, 1	-	0
500	int	Device password	0 .. 9999	-	xxxx
501	int	Homepage, password mode	0, 2, 128, 130	-	0
502	int	Homepage, password	0 .. 9999	-	xxxx
510	pw1	Activate "EMAX" option, licence part 1	0 .. 999	-	xxx
511	pw2	Activate "EMAX" option, licence part 2	0 .. 999	-	xxx
600	int	LCD contrast	0 .. 99	-	70
601	int	LCD backlight, max. brightness	0 .. 16	-	0
602	int	LCD backlight, min. brightness	0 .. 8	-	0
603	int	LCD backlight, on-time	0 .. 9999	sec	0



Appendix

Measured value displays

You can have the following measured values shown on the display, with the default factory setting, using keys 1 and 2. The measured value names used are abbreviated and have the following meaning:

- Active power demand = active power demand, imported supply
- Reactive power = reactive power, inductive
- Active power demand = active power demand, imported supply with return block

Voltage L1-N	Voltage L2-N	Voltage L3-N	Voltage L4-N		
Voltage L1-L2	Voltage L2-L3	Voltage L3-L1			
Current L1	Current L2	Current L3	Current L4		
Active Power demand L1	Active Power demand L2	Active Power demand L3	Active Power demand L4	Active Power demand L1..L3	Active Power demand L1..L4
Reactive Power L1	Reactive Power L2	Reactive Power L3	Reactive Power L4	Reactive Power L1..L3	Reactive Power L1..L4
Active Energy demand L1	Active Energy demand L2	Active Energy demand L3	Active Energy demand L4	Active Energy demand L1..L3	Active Energy demand L1..L4
cos(phi) L1	cos(phi) L2	cos(phi) L3	cos(phi) L4	cos(phi) L1..L3	
Frequency Rotating field	Temperature input	Date	Time	Serial number	Firmware Release

Declaration of conformity

The EM-PQ2200 fulfils the safety requirements of:

Directive 89/336/EEC in conjunction with DIN EN 61326-1:2006 as well as Directive 2006/95/EC in conjunction with EN 61010-1 (2002-08)

Safety requirements

Safety requirements for electrical instrumentation, control and laboratory equipment
: EN 61010-1 08:2002, IEC 61010-1:2001

Protection class : II (device without protective conductor)

EMC requirements

Emitted interference, residential area: DIN EN61326-1:2006, Class B, IEC61326-2-1:2005

Interference immunity, industrial area : DIN EN 61326-1:2006, Table 2, IEC 61326-2-1:2005

Housing : Electrostatic discharge, IEC 61000-4-2 (4 kV/8 kV)
: Electromagnetic fields, IEC 61000-4-3:2002 (10 V/m)
: Electromagnetic fields, IEC 61000-4-8:2000 (100A/m)

Power supply voltage : Voltage dips, IEC 61000-4-11 (0.5 periods)
: Bursts, IEC 61000-4-4 (2 kV)
: Surge voltages, IEC 61000-4-5 (1 kV L to N)
: Conducted HF signals, IEC 61000-4-6 (3 V)

Measurement inputs : Surge voltages, IEC 61000-4-5 (2 kV)
: Conducted HF signals, IEC 61000-4-6 (3 V)
: Bursts, IEC 61000-4-4 (2 kV)

RS485, RS232, ethernet, digital inputs and outputs, temperature measurement input
: Conducted HF signals, IEC 61000-4-6 (3 V)
: Bursts, IEC 61000-4-4 (1 kV)

RS485, ethernet, digital inputs and outputs, temperature measurement input
: Surge voltages, IEC 61000-4-5 (2 kV)

Electrical measuring transducer for converting alternating current variables into analog or digital signals.
: DIN EN 60688 April 2002,
: IEC 60688:1992 +A1:1997+ A2:2001

Dimensioned drawings

Front view

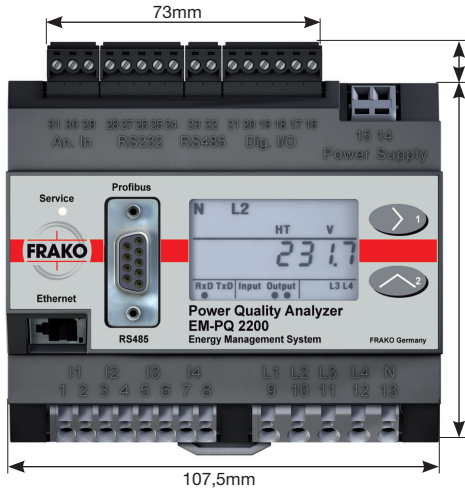

Side view

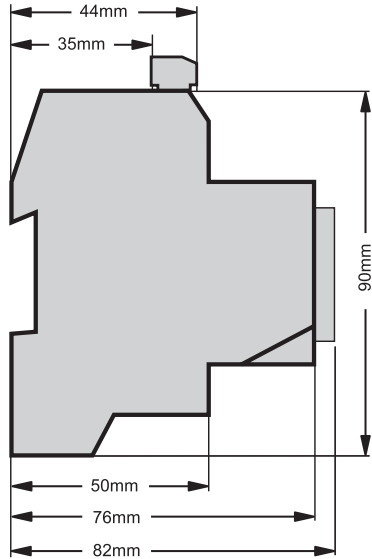

EM-PQ2200 connection example

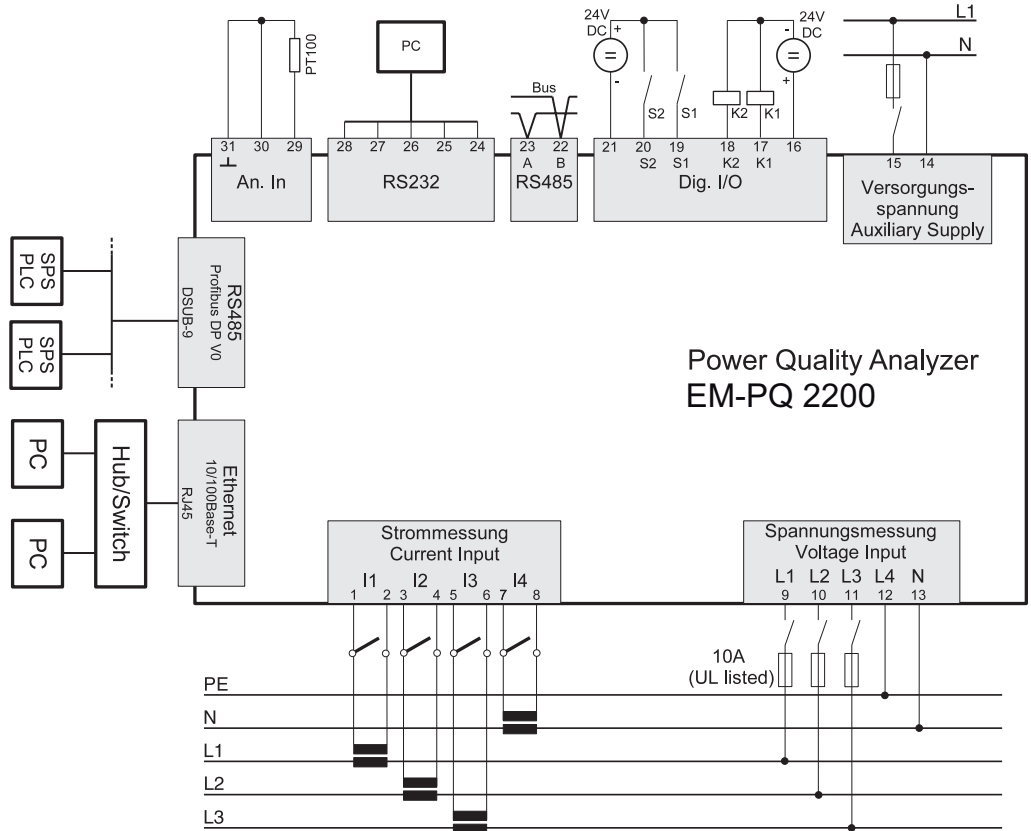

Quick Reference Instructions

Adjusting the primary current

You have three current transformers of the same type with a current transformer ratio of 200 A/5 A. You would like to program the primary current with 200 A.

To do this you must enter the value 200 for the primary current in the address 000.

The secondary current is preset to 5 A in address 001 in the factory.

Switch to Program mode

Simultaneously press keys 1 and 2 for around one second.

The PRG symbol for programming mode appears.

The content of address 000 is displayed.

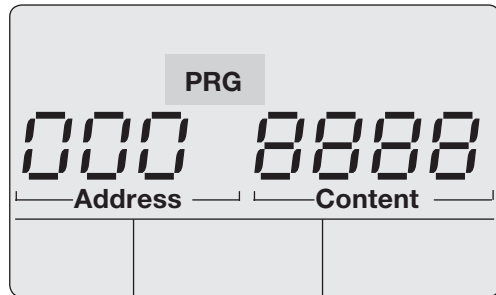

Change address

As address 000 is already displayed the address does not have to be changed.

Enter the primary current.

Use Key 1 to select the digit to be changed.

Use Key 2 to change the selected digit.

Exit program mode

Simultaneously press both keys for around 1 second.

The current transformer setting is saved and the device returns to display mode.

