

Power Quality Analyzer

EM-PQ 2500

Operating Manual

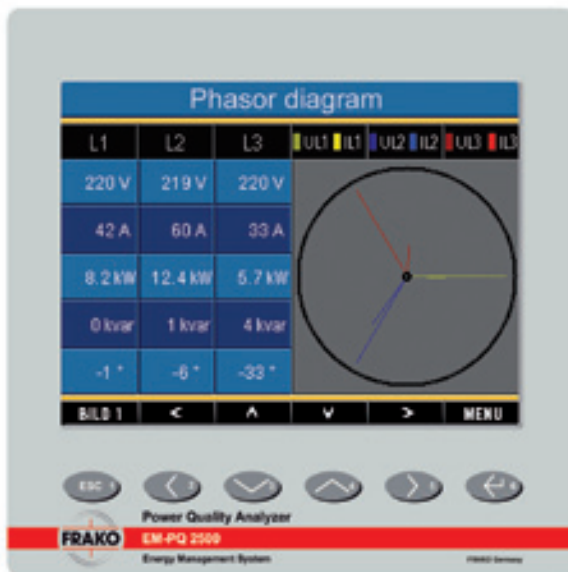

Index of Contents

General	3	Configuration	44
Goods-in Check	6	Language	45
Description	8	Communication	46
Intended Use	8	Measurement	48
Features	9	Transients	54
Measurement Method	10	Events	56
EM-PQ VIS software	11	Display	58
Assembly	12	System settings	60
Place of Installation	12	Password	61
Installation extradata	12	Delete minimum and maximum values	62
Front Board Cutout	12	Delete power meters	63
Ethernet Connection	13	Extensions	66
Fixing	13	Initialization	70
Installation	14	Applying the supply voltage	70
Supply Voltage	14	Apply measurement voltage	71
Voltage Measurement	16	Rotary field direction	71
Current measurement	22	Applying measurement current	72
RS485	26	Checking the power measurement	74
Ethernet	30	Checking communication	75
Digital outputs	32	Profibus	76
Digital Inputs	34	Service and Maintenance	80
Operation	36	Technical data	84
Measurement value displays	37	Dimensioned drawings	94
"Home" measurement value display	38	Configuration overview	96
Select measurement value display	39	Measurement value displays overview	98
Call up additional information	40	Connection example	100
Delete min/max values individually	41		
List of transients	42		
List of events	43		

General

Copyright

This handbook is subject to the legal regulations of copyright law protection and may not be mechanically or electronically photocopied or reprinted in full in or parts and, without the legal, written permission of

FRAKO

Kondensatoren- und Anlagenbau GmbH

Tscheulinstr. 21a

D - 79331 Teningen, Germany

may not be reproduced or further publication in any other way.

Protected trademarks

All trademarks and the resulting rights belong to the respective owners of the rights.

Disclaimer

FRAKO Kondensatoren- und Anlagenbau GmbH does not accept any liability for errors or deficits in this handbook and is not obliged to keep the contents of this handbook updated.

Comments on the handbook

We welcome your comments. If anything in this handbook seems unclear, please let us know and send us an EMAIL to:

info@frako.de

Meaning of Symbols

The following pictograms are used in this hand-book:



Gefährliche Spannung!

Danger of death or risk of major injury. Disconnect the system and device before beginning any work.



Caution!

Please pay attention to the documentation. This symbol should warn against possible dangers that can occur during assembly, initialization and use.



Note.



Protective ground connection.



Inductive.

The voltage lags the current



Capacitive.

The voltage lags the current.

Application Information

Please read this operating manual and all other publications that have to be consulted to work with this product (particularly for installation, operation or maintenance).

Please pay attention to all safety regulations and warning information. If you fail to follow the information, it can result in personal damage and/or damages to the product.

Any unauthorized change or use of this device beyond the specified mechanical, electrical or other operating limits can cause personal damage and/or damage to the product.

Any such unauthorized change represents "misuse" and/or "negligence" in the sense of guarantee for the product and therefore makes the guarantee covering possible consequential damages void.

This device is to be exclusively operated and maintained by a specialist.

Specialists are persons who, due to their relevant training and experience, are capable of recognizing risks and avoiding possible hazards that can be caused when operating or servicing the device.

When using the device, the necessary legal and safety regulations should be considered additionally for the respective application case.



Caution!

If the device is not operated according to the operating manual, protection is no longer ensured and the device may cause dangers.



Cables with single wires must be provided with ferrules.



Only screw plugs with the same pole number and the same type of construction can be plugged together.

Goods-in Check

Correct and safe operation of this device is subject to appropriate transportation, correct warehousing, installation and assembly as well as careful operation and maintenance. If it can be assumed that safe operation without any danger is no longer possible, the device must be taken out of operation immediately and secured against unintentional initialization.

Unpacking and packing must take place, with the usual care without applying force and using suitable tools. The devices must be checked for perfect condition with visual tests.

It should be assumed that risk-free operation is not possible if, for example:

- There is visible damage,
- it no longer works due despite the main supply being intact,
- has been subject to unfavorable conditions (e.g. storage outside of the authorized climate limits without adaptation to the room climate, thawing etc.) over a longer period of time or transport stresses (e.g. a fall from a height, including without any visible external damage etc).
- Please check the delivered items for completeness before starting with the installation of the device.



All screw clamps that belong to the scope of supply are attached to the device.



The operating manual also describe options that do not belong to the scope of supply.



All supplied options and design versions are described on the delivery note.

Goods-in Check

Scope of Supply

Number	Name
1	EM-PQ2500
1	Operating manual
1	CD with the following contents: <ul style="list-style-type: none">- Configuration and visualization software „EM-PQ VIS“- Functional descriptions, EM-PQ VIS, EM-PQ2500 ..- GSD file „U5080C2C.GSD“ for Profibus DP V0
1	Screw clamp, pluggable, 2-pole (auxiliary power).
1	Screw clamp, pluggable, 5-pole (voltage measurement 1-4).
1	Screw clamp, pluggable, 8-pole (current measurement 1-4).
1	Screw clamp, pluggable, 6-pole (digital outputs).
1	Screw clamp, pluggable, 5-pole (digital inputs).
1	3m patch cable, blue (Connection EM-PQ2500 - switch/hub).
1	2m patch cable, twisted (connection EM-PQ2500 - PC).
1	fixing clips.

Available accessories

Name
Profibus plug, 9-pole DSUB, with integrated switchable terminating resistors. Seal, 144x144.

Description

Intended Use

The EM-PQ2500 is intended for measurements in the building installation, on distributors, power switches and bus bars.

Measurement voltages and measurement currents must come from the same network.

The EM-PQ2500 is suitable for installation in switch boards with a fixed, weather-protected extradata.

The EM-PQ2500 can be used in 2, 3 and 4 supply networks and in TN and TT networks.

The current measurement inputs of the EM-PQ2500 are connected using external $\dots/1A$ or $\dots/5A$ current transformers.

The measurement in medium and high-voltage networks generally takes place using current and voltage transformers.

The EM-PQ2500 can be used in residential and industrial areas.

Measurement results can be displayed, saved and read-out using serial interfaces for further processing.

Features

- Front board installation, 144x144mm,
- Working temperature range -10°C .. +55°C,
- Colour graphic display 320x240, 256 colours, 6 keys,
- 8 digital inputs, 5 digital outputs,
- 16Bit A/D transformer, data memory 256MByte Flash, SDRAM 32Mbyte,
- Continuous scanning of voltage and current measurement inputs with 20kHz,
- Frequency range of fundamental oscillation 40Hz .. 70Hz
- 4 voltage measurement inputs, 4 current measurement inputs,
- Measurement in TN and TT networks,
- RS485: Profibus DP/V0, Modbus RTU, Modbus-Master,
- Ethernet: Web-Server, EMAIL, BACnet (Option), TCP/IP, EMAIL (SMTP), DHCP-Client (BootP), Modbus/TCP, Modbus RTU over Ethernet, FTP, ICMP (Ping), NTP, TFTP, SNMP.
- Detection of transients >50µs and storage with up to 16000 scanning points,
- Detection of more than 800 measurement values,
- Measurement of harmonics 1 to 40, for
 - UIn, I, P (ref/supply) and
 - Q (ind/cap),
- Programming own applications in Jasic.

Measurement Method

The EM-PQ2500 measures without any gaps and calculates all effective values over a 200ms Interval.

The EM-PQ2500 measures the real effective value (TRMS) of the voltages and currents applied to the measurement inputs.

Operating Concept

You can program the EM-PQ2500 in several ways and call up measurement values.

- **Direct-** on the device using 6 keys and the display.
- Using the configuration and visualization software **EM-PQ VIS**.
- Using the EM-PQ2500 **homepage** for devices with an Ethernet interface.
- Using the RS485 with the **Modbus**-protocol. You can change and call up data with the help of the Modbus address list (stored on the enclosed data carrier).

Only operating the EM-PQ2500 using the integrated display and the 6 keys is described in this operating manual.

The EM-PQ VIS configuration and visualization software and the homepage have their own "on-line assistance".

EM-PQ VIS configuration and visualization software

The EM-PQ2500 can be programmed and read-out with the EM-PQ VIS configuration and visualization software included in the scope of supply. A PC must be connected using a serial interface (RS485/Ethernet) to the EM-PQ2500.

EM-PQ VIS features

- Programming the EM-PQ2500.
- Configuration of recordings.
- Recordings read-out.
- Saving data in a database.
- Graphic presentation of measurement values.
- Programming specific applications for the client.

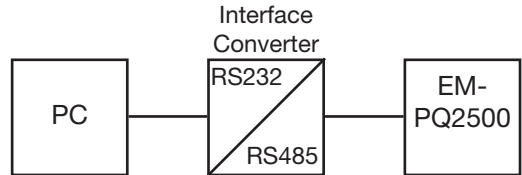

Illu. Connection of a EM-PQ2500 to a PC using an interface converter.

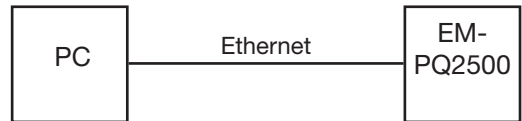

Illu. Connection of a EM-PQ2500 to a PC using Ethernet.

Assembly

Place of Installation

The EM-PQ2500 is suitable for installation in fixed, weather protected switch boards. Conducting switch boards have to be grounded.

Installation extradata

In order to achieve sufficient ventilation, the EM-PQ2500 has to be installed vertically. The clearance has to be at least 50mm at the top and bottom and 20mm at the side.

Front Board Cutout

Cutout size: $138^{+0.8} \times 138^{+0.8}$ mm

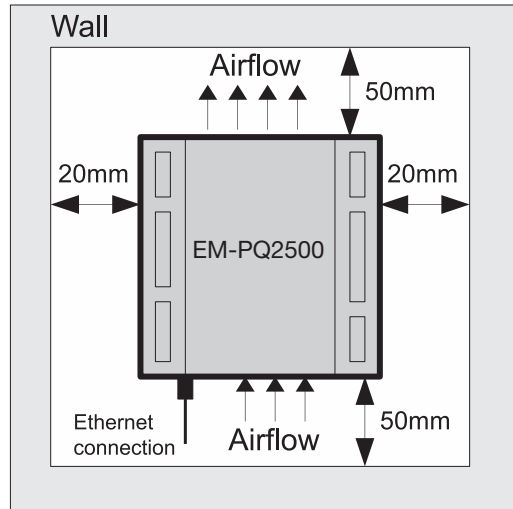

Illu. EM-PQ2500 installation extradata; view from back.



Failure to maintain the minimum clearances can destroy the EM-PQ2500 at high environmental temperatures!

Ethernet Connection

The EM-PQ2500's Ethernet connection is located on the underside of the housing. Depending on the bending radius of the Ethernet cable and plug type, you must provide a connection area beneath the EM-PQ2500.

The connection area beneath the EM-PQ2500 should not be less than 50 mm.

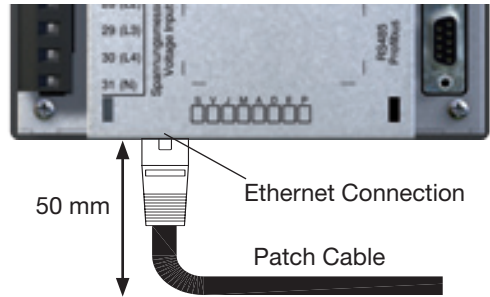

Fixing

The EM-PQ2500 is fixed into the switch board with two fixing clips that are each mounted on the device at the top and bottom.

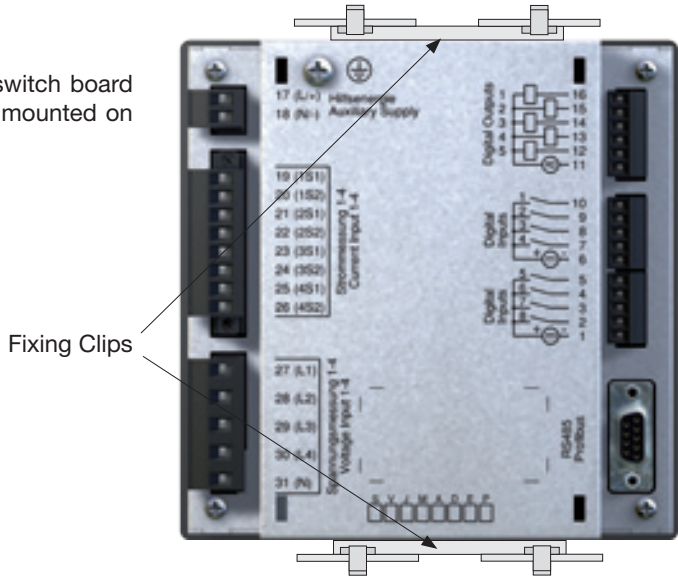

Installation

Protective Wire Connection

Use a ring cable lug for connecting the protective wire to the EM-PQ2500.

Supply Voltage

A supply voltage is required to operate the EM-PQ2500. The type and level of the necessary supply voltage is noted on the label.

Before applying the supply voltage, make sure that the voltage and the frequency match the details on the label!

The connection cables for the supply voltage must be connected using a fuse. Use a UL/IEC listed fuse (6A type C).



Warning - danger of death!

It is necessary for the protective wire connection on the device to be connected with the system grounding.

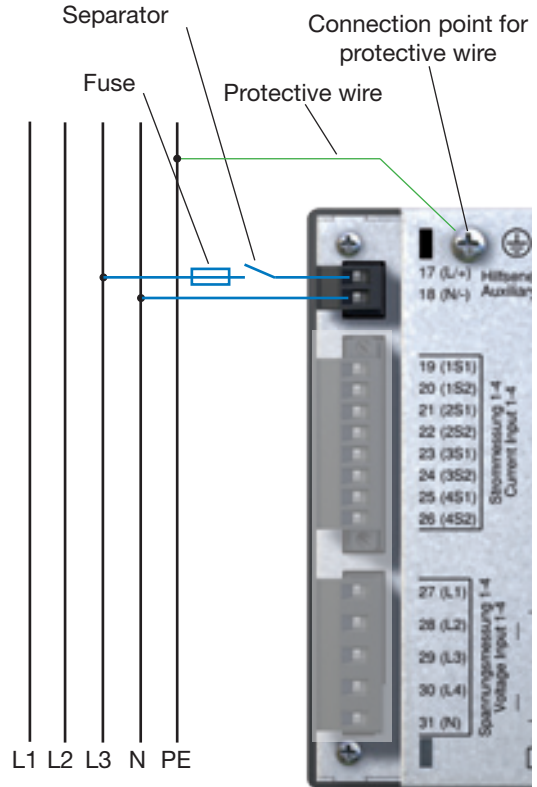

Illu. Connection example; connection of supply voltage to a EM-PQ2500.

Installation



Warning!

The inputs for the supply voltage are dangerous to touch!



Warning!

Please pay attention to the details on the supply voltage provided on the EM-PQ2500 label.



- An isolator or circuit breaker must be provided for the voltage supply in building installation.

- The isolator must be attached near to the device and must be easy for the user to access.

- The switch must be marked as a separator for this device.

- Voltages above the authorized voltage range can destroy the device.

Voltage Measurement

Three-phase 4 conductor systems

The EM-PQ2500 can be used in three-phase 4 conductor systems (TN, TT network) with a grounded neutral wire. The bodies of the electrical system are grounded.

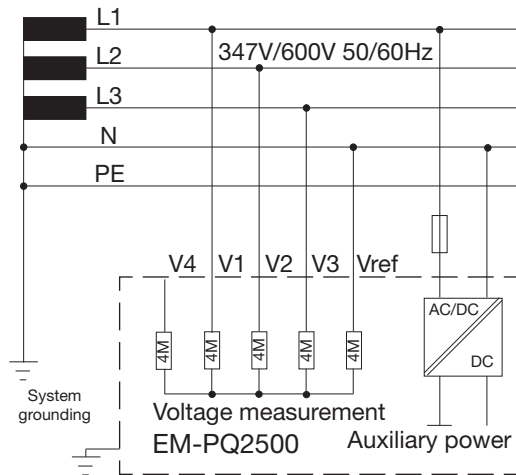

Illu. Basic circuit diagram, EM-PQ2500 in the TN-network.

Three-phase 3 conductor systems

The EM-PQ2500 is only suitable for use in IT networks with restrictions, because the measurement voltage is measured against the housing potential and the input impedance of the device causes a leakage current against ground. The leakage current can cause isolation monitoring in IT networks to respond.

Connection variations with a voltage transformer are suitable for IT networks without any restrictions.

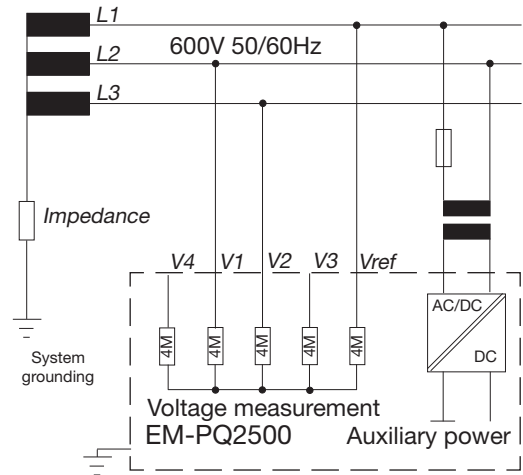

Illu. Basic circuit diagram, EM-PQ2500 in the IT network without N.

Installation

Nominal Voltages

Lists of the networks and their nominal network voltages in which the EM-PQ2500 can be used.

Three-phase 4 conductor systems with grounded neutral wire.

U_{L-N} / U_{L-L}	
66V / 115V	
120V / 208V	
127V / 220V	
220V / 380V	
230V / 400V	
240V / 415V	
260V / 440V	
277V / 480V	Maximum nominal voltage of the network according to UL
347V / 600V	
400V / 690V	Maximum nominal voltage of the network
417V / 720V	

Illu. Table of suitable network nominal voltages for the voltage measurement inputs according to EN60664-1:2003.

Ungrounded three-phase 3 conductor systems.

U_{L-L}	
66V	
115V	
120V	
127V	
200V	
220V	
230V	
240V	
260V	
277V	
347V	
380V	
400V	
415V	
440V	
480V	
500V	
577V	
600V	Maximum nominal voltage of the network

Illu. Table of suitable network nominal voltages for the voltage measurement inputs according to EN60664-1:2003.

Voltage Measurement Inputs

The EM-PQ2500 has 4 voltage measurement inputs (V1, V2, V3, V4).

Overvoltage

The voltage measurement inputs are suitable for measurements in networks in which overvoltages in the overvoltage category 600V CATIII can occur.

Frequency

The EM-PQ2500 requires the rated frequency for measuring and calculating measurement values.

The EM-PQ2500 is suitable for measurements in networks with a rated frequency in the range of 40Hz to 70Hz.

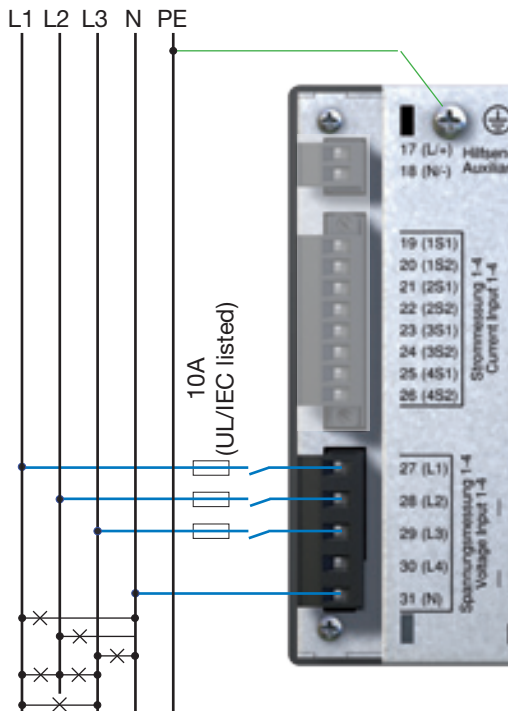

Illu. Connection example for voltage measurement.



A connection diagram does not have to be configured for the measurement inputs V4 and I4.

Installation

The following has to be considered when connecting the voltage measurement:

- A suitable separator is to be provided in order to disconnect the EM-PQ2500 from the current and voltage.
- The separator must be placed near to the EM-PQ2500, labelled for the user and must be easy to reach.
- Use UL/IEC authorized overcurrent protection and isolators (10A type C) only.
- The overcurrent protection device must have a nominal value calculated for the short-circuit current at the connection point.
- Measurement voltages and measurement currents must come from the same network.



Warning!

Voltages that exceed the authorized network nominal voltages must be connected using a voltage converter.



Warning!

The EM-PQ2500 is not suitable for measuring DC voltages.



Warning!

The voltage measurement inputs on the EM-PQ2500 are dangerous to touch!



Warning!

The voltage measurement inputs may not be used for voltage measurement in SELV circuits (Safety Extra Low Voltage).

Installation

Connection diagrams, voltage measurement

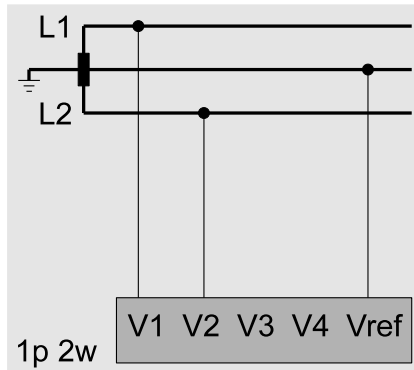
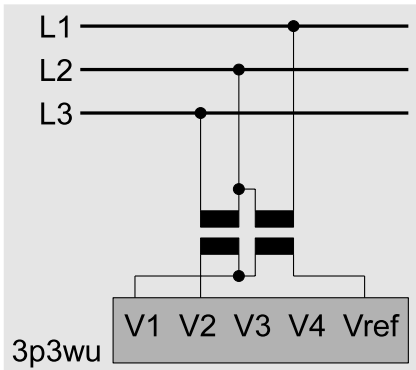
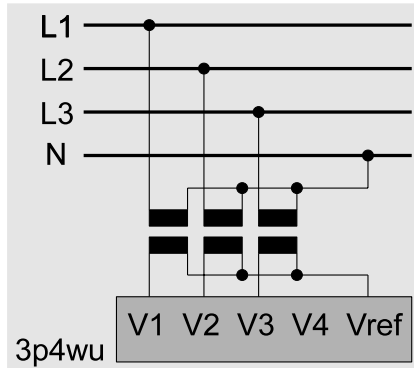
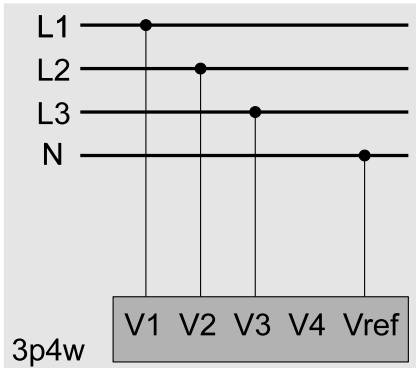

Installation

Connection diagrams, current measurement

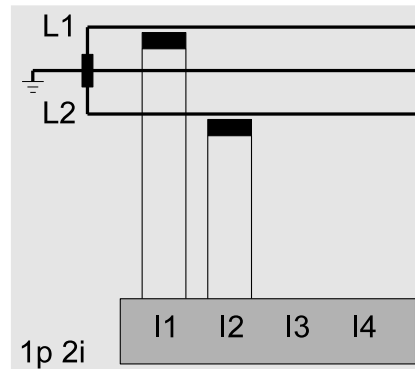
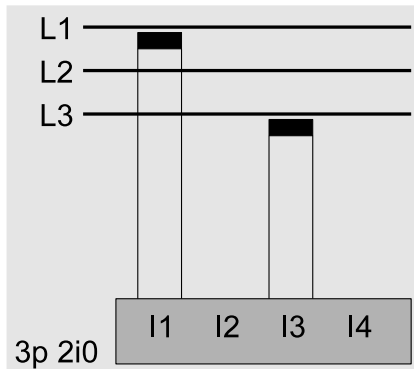
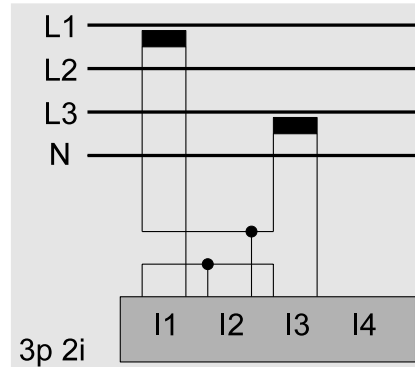
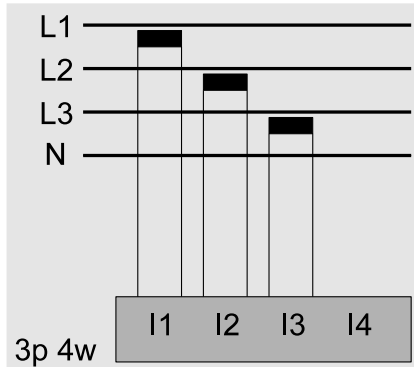

Current measurement

The EM-PQ2500 is designed for connecting current converters with secondary currents of $.1A$ and $.5A$. Only alternating currents, and no direct currents, can be measured. Each current measurement input can be loaded with 120A for 1 second.



Warning!
The current measurement inputs are dangerous to touch.



Warning!
The EM-PQ2500 is not suitable for the measurement of direct voltages.



Grounding current converters!
If a connection is provided for grounding the secondary winding, this must be connected with ground.

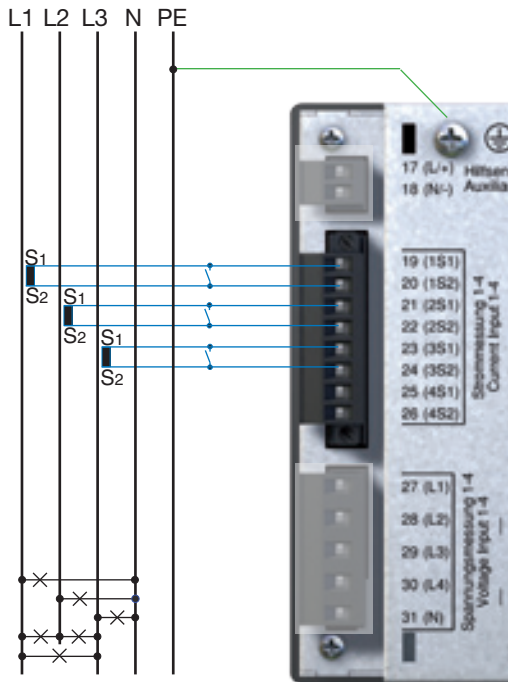

Illu. Connection example, current measurement using current converter.



A connection diagram does not have to be configured for measurement inputs V4 and I4.

Current Direction

The current direction can be corrected on the device or individually using the available serial interfaces for each phase.

In the case of incorrect connection, subsequent reconnection of the current converter is not necessary.



Current converter connections!

The secondary connections of the current converter must be short-circuited to these before the electricity cables are disconnected from the EM-PQ2500!

If a test switch is available which automatically shorts the secondary current converter lines, it is sufficient to set them to the "test" extradata, as long as the short-circuiters have been checked beforehand.



Open current converters!

Extreme contact danger due to voltage peaks can occur on current converters that are operated open on the secondary side!

For "anti-open current converters", the winding isolation is calculated so that the current converters can be operated open. However, these current converters are also dangerous to touch if they are operated open.

Total current measurement

If the current is measured using two current converters, the total transfer ratio of the current converters must be programmed in the EM-PQ2500.

Example

The current measurement takes place using two current converters. Both current converters have a transfer ratio of 1000/5A. The total measurement is carried out with a 5+5/5A total current converter.

The EM-PQ2500 must then be set as follows:

Primary current: $1000A + 1000A = 2000A$

Secondary current: $5A$

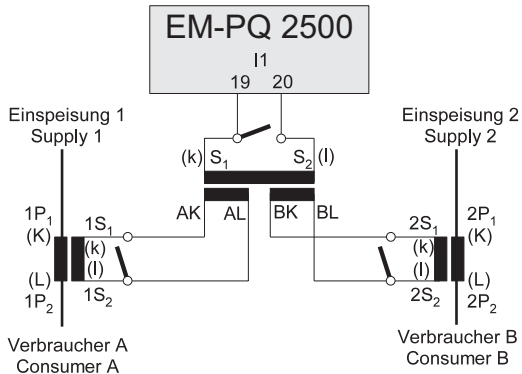

Illu. Example, current measurement using a total current converter.

Direct measurement

Nominal currents up to 5A can also be directly measured with the EM-PQ2500.

Under consideration that the direct measurement will be carried out for the current only in three phase 4 wire systems with mains voltage till

- 127V/220V (300V CAT III) according UL
- 277V/480V (300V CAT III)

and three phase 3 wire systems with mains voltage till

- 277V (300V CAT III) according UL
- 480V (300V CAT III)

Due to the fact that the EM-PQ2500 does not have integrated protection for the current measurement, this protection must be foreseen in the installation.

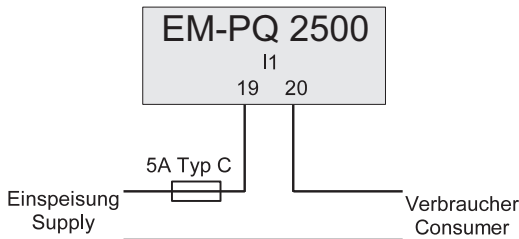

Illu. Example, direct current measurement.

Ampere meter

If you do not want to measure the current with the EM-PQ2500 alone, but also with an additional ampere meter, the ampere meter must be switched in series to the EM-PQ2500.

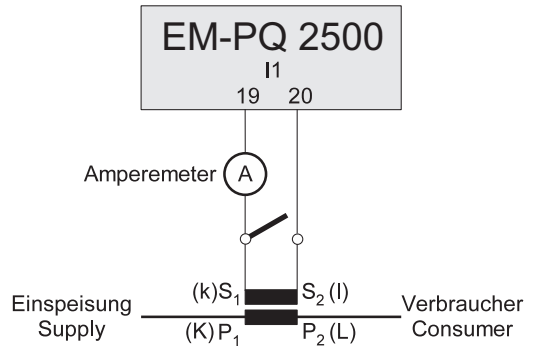

Illu. Example, current measurement with an additional ampere meter.

RS485

The RS485 interface is designed as a 9-pole DSUB socket on the EM-PQ2500.

On this interface, the EM-PQ2500 supports the following selection of protocols:

- Modbus RTU
- Profibus DP V0 Slave

For connection, we recommend a 9-pole Profibus plug, e.g. from the company Phoenix, type "SUBCON-Plus-ProfIB/AX/SC" with article number 2744380.

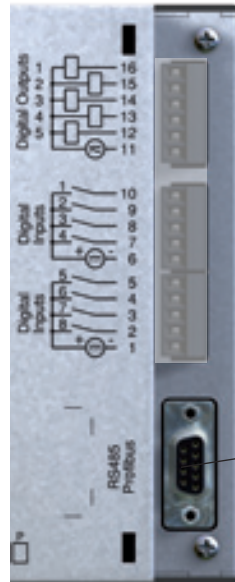

DSUB socket
for Modbus
or Profibus.

Illu. EM-PQ2500 with DSUB socket for the RS485 interface.

Installation

Connection of Bus Lines

The incoming bus line is connected to clamps 1A and 1B. The bus line for the next device in the line is connected to clamps 2A and 2B. If there is no further device in the line, the bus line has to be terminated with resistors (switch to ON).

In switch extradata ON, clamps 2A and 2B are switched off for the continuing bus line.

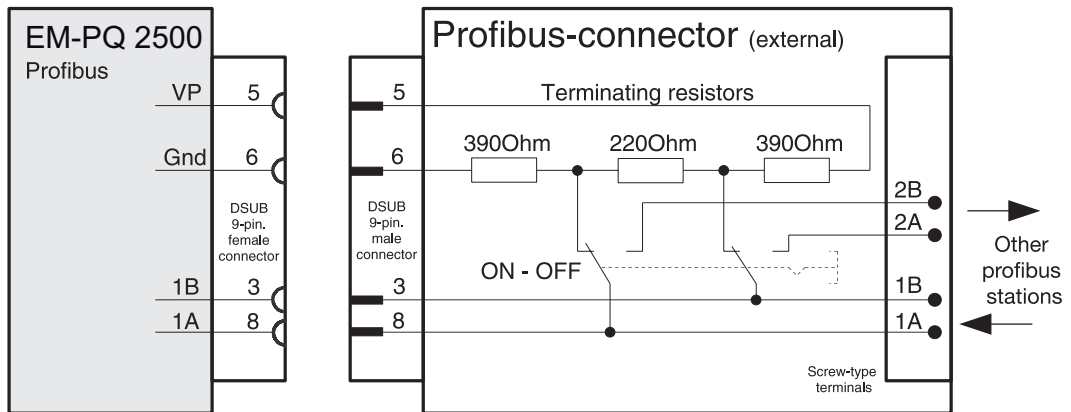

Illu. Profibus plug with terminating resistors.

Installation

Shields

A twisted, shielded cable is foreseen for connections using the RS485 interface.

- Ground the shields of all cables leading to the cabinet at the cabinet entry point.
- Connect the shield extensively and with good conductivity with a low external voltage ground.
- Intercept the cable mechanically above the ground clip in order to avoid damages caused by cable movements.
- Use suitable cable insert guides, such as PG glands, to guide the cable into the switch cabinet.

Cable type

The cables used must be suitable for an environmental temperature of at least 80°C.

Recommended cable types:

Unitronic Li2YCY(TP) 2x2x0.22 (Lapp cable)

Unitronic BUS L2/FIP 1x2x0.64 (Lapp cable)

Maximum cable length

1200m at a Baud rate of 38.4k.

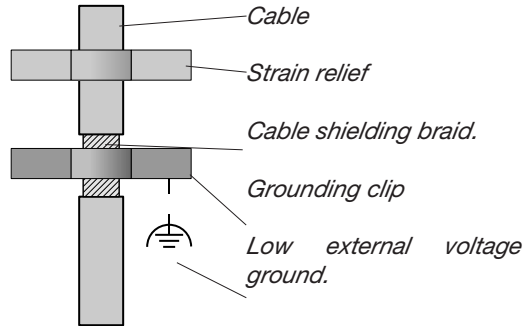

Illu. Shielding arrangement at cabinet entry point.

Terminal resistors

The cable is terminated with resistors (120Ohm 1/4W) at the beginning and end of a segment.

The EM-PQ2500 does not have any terminal resistors.

Installation

Bus structure

- All devices are connected in a bus structure (line).
- In one segment, up to 32 participants can be switched together.
- The cable is terminated with resistors at the beginning and end of a segment.
- Repeaters (power boosters) must be used with more than 32 participants in order to connect the individual segments.
- Devices with terminated resistor have to be supplied.
- We recommend to install the master device at the end of the segment.
- In case that the master device with terminated bus resistor will be removed, the bus is not under operation.
- In case that slave device with terminated bus resistor will be removed or is not switched on, the bus is can be unstable.
- Devices which have no termination can be replaced without any interruption of the bus.

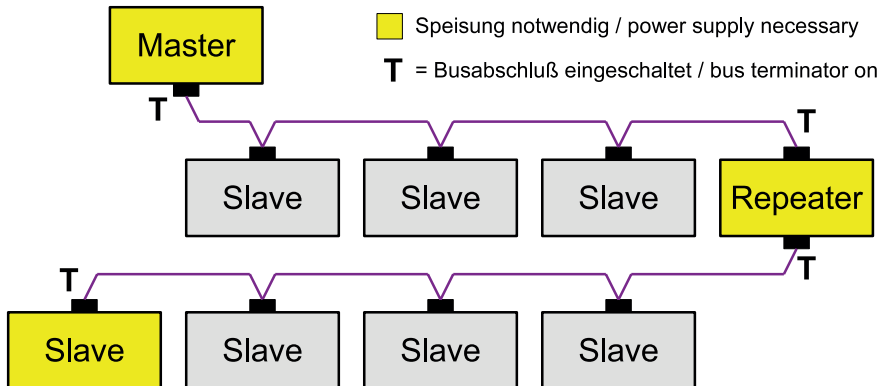

Ethernet

The network settings for the Ethernet are specified by the network administrator and set accordingly on the EM-PQ2500.

If the network settings are not known, the patch cable may not be plugged into the EM-PQ2500.

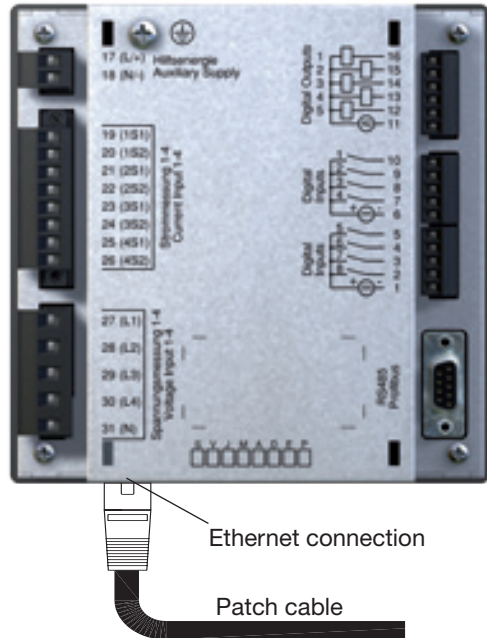

Warning!
Incorrect network settings can cause faults in the network!

Installation

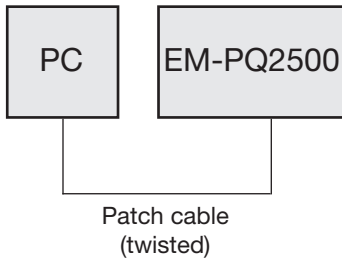

Illu. Connection example; direct connection between the EM-PQ2500 and PC using a twisted patch cable.

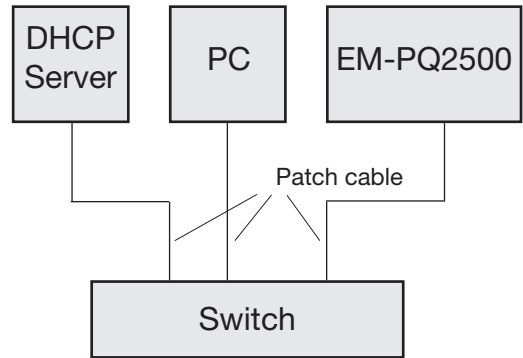

Illu. Connection example; EM-PQ2500 and PC are automatically allocated the IP address from a DHCP server.

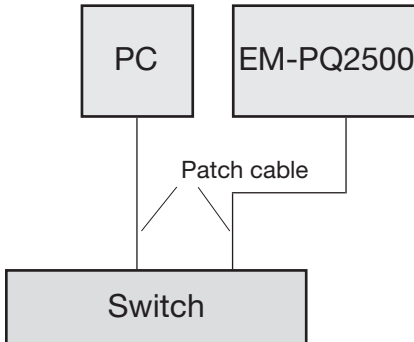

Illu. Connection example; EM-PQ2500 and PC need a fixed IP address.

Digital outputs

The EM-PQ2500 has 5 digital outputs. These outputs are separated galvanically from the analysis electronics using optocouplers. The digital outputs have a common reference.

- The digital outputs can switch AC and DC loads.
- The digital outputs are **not** short-circuit proof.
- Connected lines that are longer than 30m must be laid with shields.
- External auxiliary power is necessary.

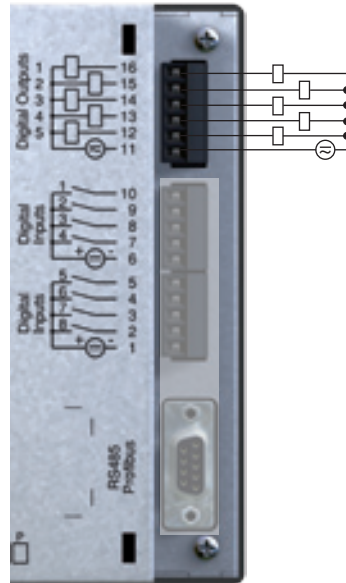

Illu. Digital outputs connection.

Installation

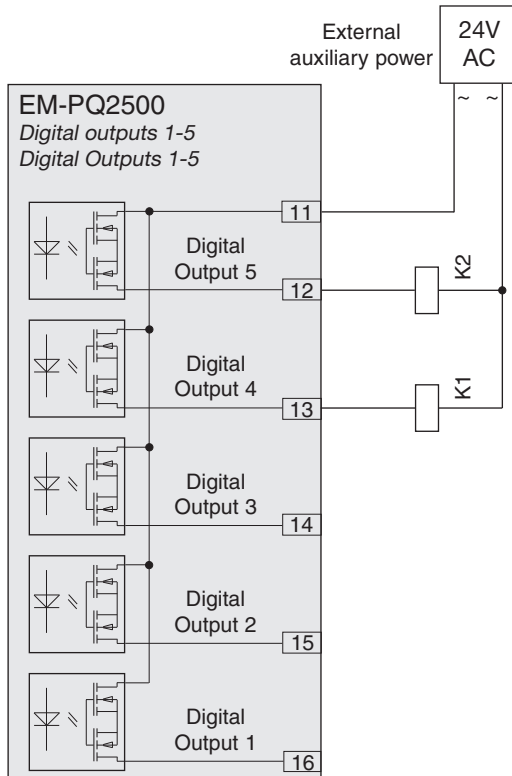

Illu. Connection of two relays to digital outputs 4 and 5.

Installation

Digital Inputs

The EM-PQ2500 has 8 digital inputs. The digital inputs are divided into two groups, each with 4 inputs. Each group has a common reference.

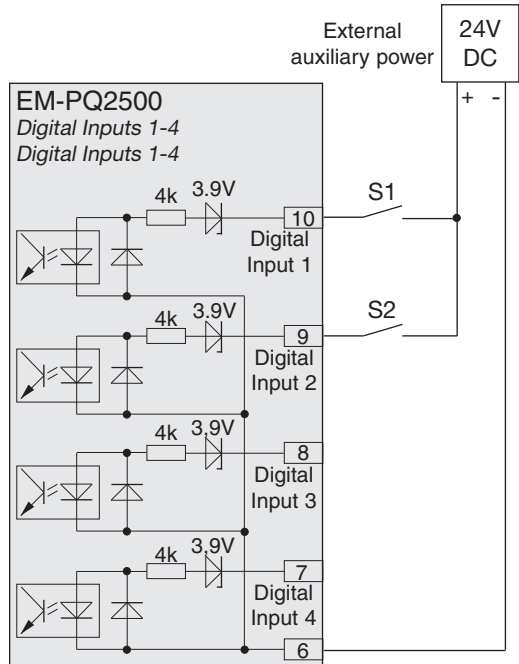
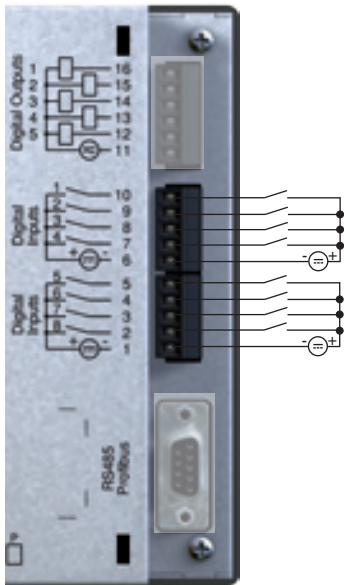

Illu. Example for the connection of digital inputs.

Illu. Example for the connection of external contacts S1 and S2 to the digital inputs 1 and 2.

Installation

S0 impulse input

You can connect an S0 impulse generator in accordance with DIN EN62053-31 to each digital input.

You require an external auxiliary voltage with an output voltage in the range of 20 .. 28V DC and a resistor with 1.5kOhm.

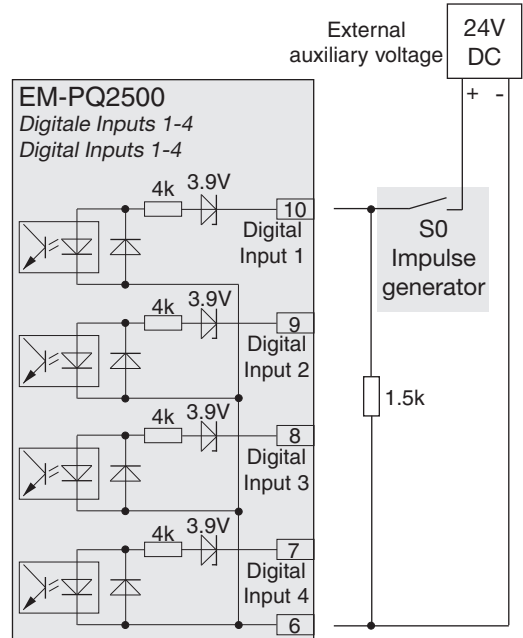

Illu. Example for the connection of an S0 impulse generator to digital input 1.

Operation

The EM-PQ2500 is operated using six function keys.

The six keys are allocated different functions depending on the context:

- Selection of measurement value displays.
- Navigation within the menu.
- Processing the device settings.

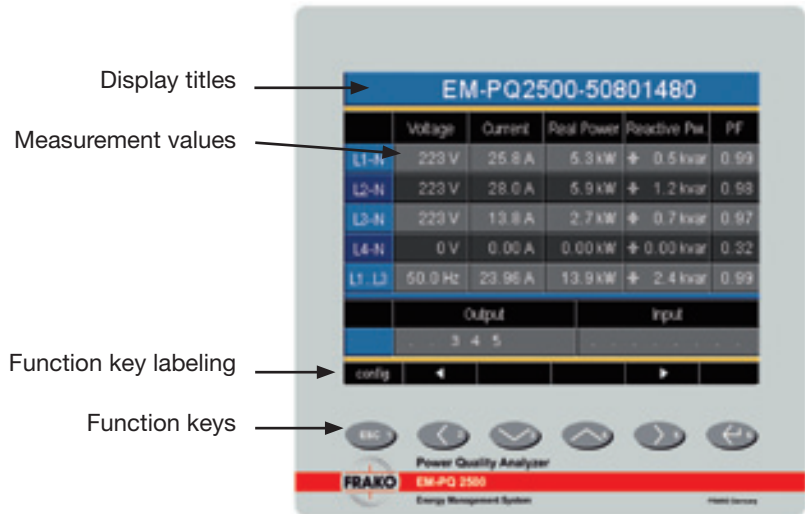

Measurement value displays

Main values

You can use keys 2 and 5 to browse between the main values of the measurement value displays.

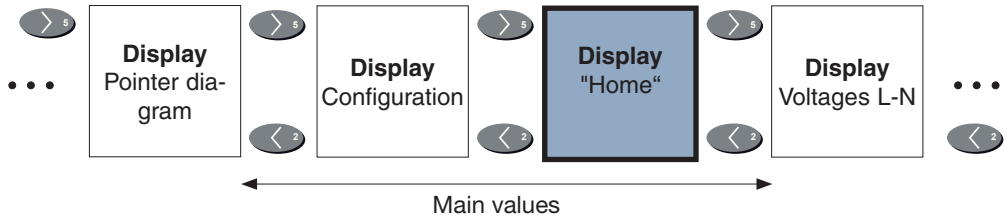

Auxiliary values

You can use keys 3 and 4 to browse between the auxiliary values of a measurement value display.

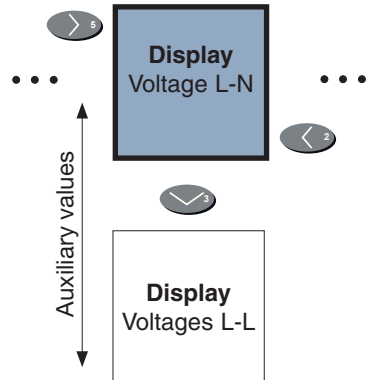

"Home" measurement value display

Once the network returns, the EM-PQ2500 starts with the "Home" measurement value display.

This measurement value display contains the device names and an overview of important measurement values. The device name consists of the device type and serial number upon delivery.

EM-PQ2500-50801480					
	Voltage	Current	Real Power	Reactive Pow	PF
L1-N	223 V	25.0 A	5.3 kW	± 0.5 kvar	0.99
L2-N	223 V	28.0 A	5.9 kW	± 1.2 kvar	0.98
L3-N	223 V	13.8 A	2.7 kW	± 0.7 kvar	0.97
L4-N	0 V	0.00 A	0.00 kW	± 0.00 kvar	0.32
L1..L3	50.0 Hz	23.96 A	13.9 kW	± 2.4 kvar	0.99
	Output		Input		
	3 4 5				
config	◀			▶	

home

ESC

Using the "Home - Key 1", you come out of the measurement value displays for the main values directly to the first "Home" measurement value display.

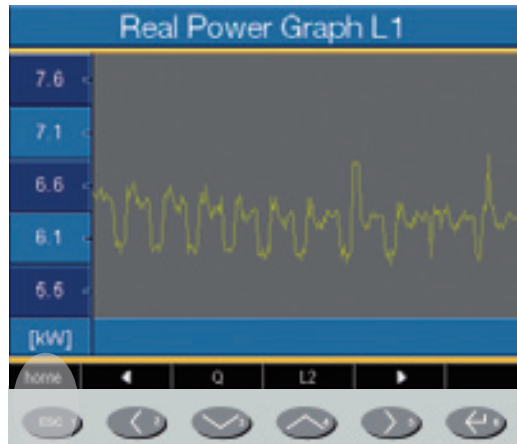

Select measurement value display

You want to change to a measurement value display with main values.

- Use the function keys 2 and 5 to browse between the measurement value displays of the main values.
- With function key 1 (Home), you always access the first measurement value display.

You want to change to a measurement value display with auxiliary values.

- Select the measurement value display with the main values.
- Select the measurement value display with function keys 3 and 4 for the auxiliary values.

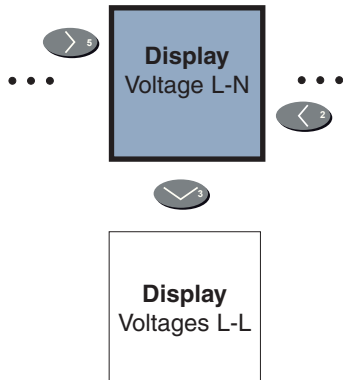

Example: selection of auxiliary value voltage.

Voltage L-N			
	Value	Min Value	Max Value
L1-N	222.9 v	213.5 v	232.6 v
L2-N	223.3 v	213.8 v	234.3 v
L3-N	224.7 v	210.3 v	235.5 v
L4-N	0.4 v	0.4 v	0.5 v

home ◀ LL ▶ select

esc < > >

Voltage L-L			
	Value	Min Value	Max Value
L1-L2	387.0 v	290.7 v	406.5 v
L2-L3	386.9 v	367.9 v	405.0 v
L3-L1	386.3 v	348.3 v	406.7 v
L4-N	0.4 v	0.4 v	0.5 v

home ◀ L-N ▶ select

Call up additional information

- Browse with keys 2 to 5 to the required measurement value display.
- Activate the measurement value selection with key 6 (selection).
- Select the required measurement value with keys 2 to 5.
- The background colour for the measurement value changes from grey to green. The additional information is shown in a blue window.
- End the process with key 1 (ESC) or select another measurement value with keys 2 to 5.

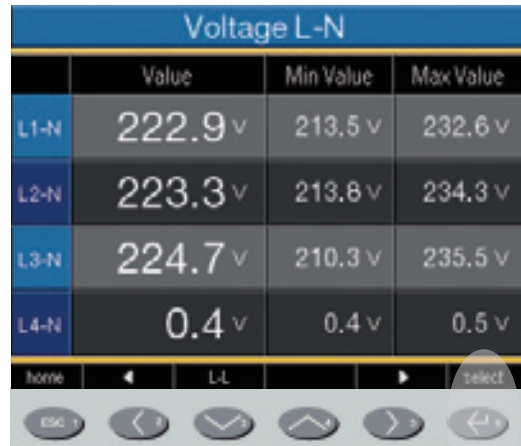

The screenshot shows a handheld device screen displaying 'Voltage L-N' data. The data is organized in a table with columns for 'Value', 'Min Value', and 'Max Value'. The rows represent different voltage measurements: L1-N, L2-N, L3-N, and L4-N. The L1-N row is highlighted in blue, and its 'Value' cell (222.9 v) is also highlighted in green. Below the table is a navigation bar with buttons for 'home', 'LL', 'select', 'esc', and directional arrows.

	Value	Min Value	Max Value
L1-N	222.9 v	213.5 v	232.6 v
L2-N	223.3 v	213.8 v	234.3 v
L3-N	224.7 v	210.3 v	235.5 v
L4-N	0.4 v	0.4 v	0.5 v

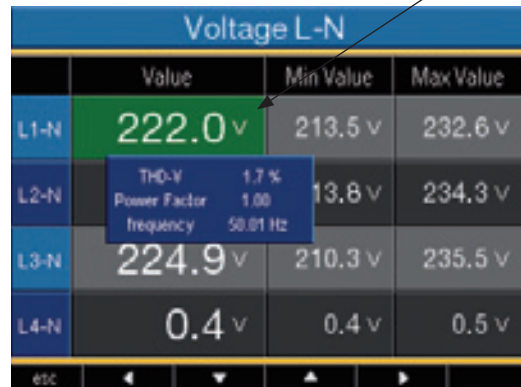

This screenshot is similar to the one above, but the L1-N value (222.0 v) is now highlighted in green. A blue information window is overlaid on the table, displaying additional data: THD-V (1.7%), Power Factor (1.00), and Frequency (50.01 Hz). The navigation bar at the bottom is also visible.

	Value	Min Value	Max Value
L1-N	222.0 v	213.5 v	232.6 v
L2-N	223.3 v	213.8 v	234.3 v
L3-N	224.9 v	210.3 v	235.5 v
L4-N	0.4 v	0.4 v	0.5 v

THD-V 1.7 %
Power Factor 1.00
Frequency 50.01 Hz

Delete min/max values individually

- Use keys 2 to 5 to browse to the required measurement value display.
- Activate the measurement value selection with key 6 (selection).
- Select the required minimum and maximum value with keys 2 to 5.
- The background colour for the measurement value changes from grey to green. The point with the date and time of occurrence is shown in an additional blue window.
- You can now delete the selected min or max value with key 6 (reset).
- End the process with key 1 (ESC) or select another min/max value with keys 2 to 5.

Voltage L-N			
	Value	Min Value	Max Value
L1-N	222.9 v	213.5 v	232.6 v
L2-N	223.3 v	213.8 v	234.3 v
L3-N	224.7 v	210.3 v	235.5 v
L4-N	0.4 v	0.4 v	0.5 v

home ◀ L-L ▶ ▶ select

esc ◀ ◻ ◻ ◻ ▶ ▶ ◀

Voltage L-N			
	Value	Min Value	Max Value
L1-N	221.9 v	213.5 v	232.6 v
L2-N	222.3 v	213.8 v	234.3 v
L3-N	225.3 v	210.3 v	235.5 v
L4-N	0.4 v	0.4 v	0.5 v

etc ◀ ◻ ◻ ◻ ▶ ▶ reset

03-08-2010 07:40:50



The date and time for the min/max values are shown in UTC time (coordinated world time).

List of transients

Recognized transients are listed in the transients list.

- The transients list consists of 2 pages.
- Transients 1 to 8 are listed on page 1 and 9 to 16 on page 2.

Display transients

- Go to the transients list with key 6 "selection".
- Select a transient with keys 3 and 4.
- Allow to the transients to be presented graphically with key 6.
- Show or hide the legends with key 6 "Legends".
- You can exit the graphic presentation of the transients with key 1.

Transients (1..8)		
Phase	Reason	Date/Time
L1	delta	2010 Jul 29 06:39:12,326
L4	delta	2010 Jul 23 11:42:59,912
L3	delta	2010 Jul 23 11:42:17,589
L4	delta	2010 Jul 9 10:00:17,112
L1	delta	2010 Jul 5 10:29:04,661
L4	delta	2010 Jul 5 10:29:01,131
L2	delta	2010 Jun 24 00:42:55,064
L2	delta	2010 Jun 21 07:07:47,104

home ◀ 9..16 ▶ select

esc < > ↘ ↙

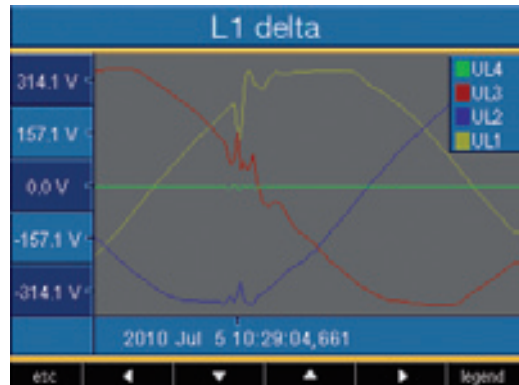

Transient voltages are quick, impulsive transient oscillation processes in electrical networks.

Transient voltages are not predictable with respect to time and have a limited period.

Transient voltages are caused by the effects of lighting, by switching operations or by triggered fuses.

List of events

Recognized events are listed in the events list.

- The events list consists of 2 pages.
- Events 1 to 8 are listed on page 1 and events 9 to 18 on page 2.

Display incident

- Go to the events list with key 6 "Selection".
- Select an incident with keys 3 and 4.
- Allow the incident to be graphically presented with key 6.
- Show or hide the legends with key 6 "Legends".
- You can leave the graphic presentation of the incident with key 1.

Events (1..8)		
Phase	Reason	Date/Time
L1	U MIN	2010 Jul 14 20:42:28,048
L1	U MIN	2010 Jul 14 20:42:27,908
L1	U MIN	2010 Jul 14 20:42:27,188
L2	U MIN	2010 Jul 14 20:42:27,635
L2	U MIN	2010 Jul 14 20:42:27,195
L2	U MIN	2010 Jul 14 20:41:14,125
L3	U MIN	2010 Jul 3 15:24:47,070
L3	U MIN	2010 Jun 10 11:38:19,079

etc | [down] | [up] | enter

ESC | [left] | [down] | [up] | [right] | [left]

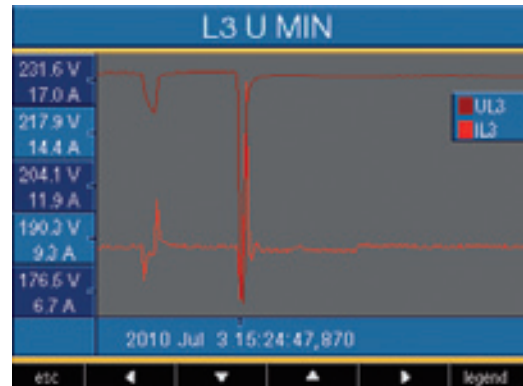

Events are limit value violations of effective current and voltage values.

Configuration

The supply voltage must be connected for configuration of the EM-PQ2500.

Apply supply voltage

- The level of supply voltage for the EM-PQ2500 can be taken from the label.
- After applying the supply voltage, a startup screen appears on the display. Approximately ten seconds later, the EM-PQ2500 changes to the first "Home" measurement value display.
- If a display does not appear, check whether the applied supply voltage is within the nominal voltage range.

EM-PQ2500-50801480					
	Voltage	Current	Real Power	Reactive Pow	PF
L1-N	223 V	25.0 A	5.3 kW	± 0.5 kvar	0.99
L2-N	223 V	28.0 A	5.9 kW	± 1.2 kvar	0.98
L3-N	223 V	13.8 A	2.7 kW	± 0.7 kvar	0.97
L4-N	0 V	0.00 A	0.00 kW	± 0.00 kvar	0.32
L1_L3	50.0 Hz	23.96 A	13.9 kW	± 2.4 kvar	0.99
	Output		Input		
	3 4 5				
config	←			→	

Illu. Example of "Home" measurement value.



Warning!

Supply voltages that do not correspond with the label details can lead to incorrect functions and damage to the device.

Configuration menu

Once the network returns, the "Home" measurement value display is found on the start page.

- Browse to the menu configuration with key 1.

If you are in a measurement value display for main values, you use

- key 1 - "Home" to directly access the first "Home" measurement display.
- Use key 1 to browse to the menu configuration.

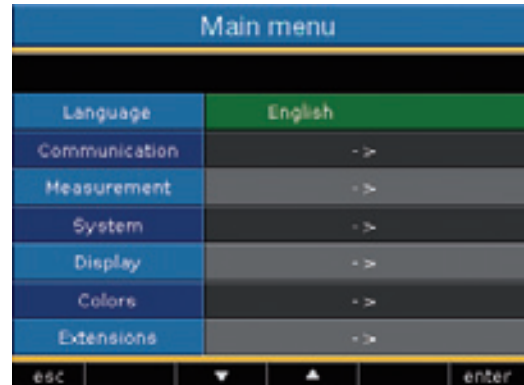
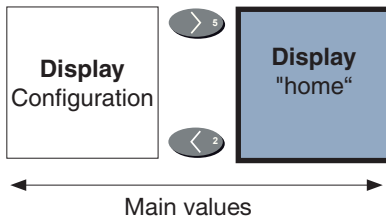

Illu. Example configuration of "languages".

Language

You can set the language for the measurement value displays and menus directly in the "configuration" menu.

There are different languages to select between. The preset language in the factory is "English".

Communication

The EM-PQ2500 has an Ethernet and a RS485 interface.

Ethernet (TCP/IP)

Select the type of address allocation for the Ethernet interface here.

DHCP mode

- **Off**- IP address, Netmask and Gateway are specified by the user and set directly on the EM-PQ2500. Select this mode for simple networks without a DHCP server.
- **BOOTP** - BootP permits the fully automatic integration of a EM-PQ2500 in an existing network. BootP is an older protocol and does not have DHCP's extent of functions.
- **DHCP**- Upon starting, the EM-PQ2500 automatically collects the IP address, the Netmask and the Gateway from a DHCP server.

Factory pre-setting: **DHCP**

Communication				
Ethernet (TCP/IP)				
DHCP	Off			
Address	78.140.98.236			
Netmask	255.255.255.240			
Gateway	78.140.98.233			
Field Bus				
RS485	Modbus Slave			
Device	1			
Speed	115200			
esc		▼	▲	enter



The EM-PQ2500 may only be connected to the Ethernet after coordinating with the network administrator!

Configuration - communication

RS485

You can specify the protocol, the device address and the Baud rate for operating the RS485 interface.

Protocol

Selection options:

- Modbus Slave
- Modbus Master/Gateway
- Profibus DP V0

Factory pre-setting:

Modbus Master/Gateway

Device address

Setting range: 0 - 255

Factory pre-setting: 1

Baud rate

Setting range: 9.600, 19.200, 38.400, 57.600,
115.200, 921.600 kbps

Factory pre-setting: 115.200 kbps

Communication			
Ethernet (TCP/IP)			
DHCP	Off		
Address	78.140.98.236		
Netmask	255.255.255.240		
Gateway	78.140.98.233		
Field Bus			
RS485	Modbus Slave		
Device	1		
Speed	115200		
esc	▼	▲	enter

Measurement

Configure here:

- The measurement converters for the current and voltage measurement.
- The record of transients.
- The recording of events.
- The rated frequency.

Measurement	
Transformer	- >
Transienten	- >
Events	- >
Rated Freq.	Auto (measurement 40-70 Hz)

esc ▾ ▲ enter

Rated frequency

For measuring and calculating the measurement values, the EM-PQ2500 requires the Rated frequency of a.c. systems.

The EM-PQ2500 is suitable for measurements in networks with a rated frequency in the range of 40Hz to 70Hz.

The rated frequency can be specified by the user or automatically detected by the device.

- **Auto**- Factory pre-setting. The rated frequency is measured.
- **50Hz**- The rated frequency is set to 50Hz. The rated frequency is not measured.
- **60Hz**- The rated frequency is set to 60Hz. The rated frequency is not measured.

Automatic frequency detection

A voltage (V_{Vref}) larger than $10V_{\text{eff}}$ must be applied on at least one of the voltage measurement inputs for the automatic detection of frequency by the EM-PQ2500.

If a sufficient measurement voltage is not applied, the EM-PQ2500 can not detect the rated frequency and a measurement can therefore not be carried out.

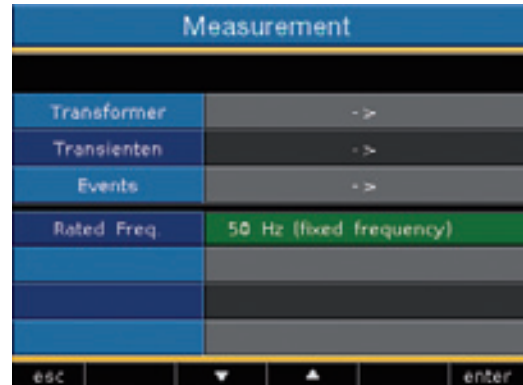

Configuration - measurement

Voltage converter

You can allocate the main measurement and the auxiliary measurement voltage converter relations.

You select the setting 400 V / 400 V for measurements without a voltage converter.

Setting range:

Primary 1 .. 999,999 V

Secondary 1 .. 400 V

Factory pre-setting:

Primary 400 V

Secondary 400 V

Transformer L1		
	primary	secondary
Current Transf.	100A	5A
Voltage Transf.	400V	400V
Rated Current	5000A	
Rated Voltage	230V	
apply to L2-L4	no	
Voltage con.	3 phase - 4 line, 3VT	
Current con.	3 phase - 4 line, 3CT	
esc	▼	▲
		enter

Nominal voltage

The nominal voltage specifies the value which

- transients,
- events and automatic graphic scaling refer to.

Setting range: 0 .. 1,000,000 V

Factory pre-setting: 230 V

For example, you can also select the primary voltage as nominal voltage.

Transformer L1		
	primary	secondary
Current Transf.	100A	5A
Voltage Transf.	400V	400V
Rated Current	5000A	
Rated Voltage	230V	
apply to L2-L4	no	
Voltage con.	3 phase - 4 line, 3VT	
Current con.	3 phase - 4 line, 3CT	
esc	▼	▲
		enter

Configuration - measurement

Connection diagram for voltage measurement

For the voltage measurement, you can select between the following connection diagrams:

- 3p4w - 3 phase 4 conductor
- 3p4wu - 3 phase 4 conductor
- 3p3w - 3 phase 4 conductor
For networks without a neutral conductor under symmetric load.
- 3p3wu - 3 Phasen 3 Leiter
For networks without a neutral conductor under symmetric load.
- 3p5w - 3 Phasen 4 Leiter
Measurement of an additional measuring point.
- 1p2w - 1 phase 2 conductor (180°)

Factory pre-setting: 3p4w

Transformer L1		
	primary	secondary
Current Transf.	100A	5A
Voltage Transf.	400V	400V
Rated Current	5000A	
Rated Voltage	230V	
apply to L2-L4	no	
Voltage con.	3 phase - 4 line, 3VT	
Current con.	3 phase - 4 line, 3CT	

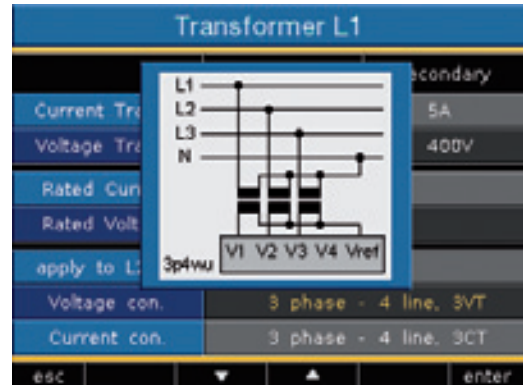

A connection diagram has to be configured for the measurement inputs V4 and I4.

Illu. Example for voltage measurement in a 3 phase 4 conductor network.

Configuration - measurement

Current converter

You can allocate both the main measurement and auxiliary measurement current converter relations.

Select setting 5/5A for direct measurement of currents.

Setting range:

Primary 1 .. 999,999 A

Secondary 1 .. 5 A

Factory pre-setting:

Primary 5 A

Secondary 5 A

Transformer L1		
	primary	secondary
Current Transf.	100A	5A
Voltage Transf.	400V	400V
Rated Current	5000A	
Rated Voltage	230V	
apply to L2-L4	no	
Voltage con.	3 phase - 4 line, 3VT	
Current con.	3 phase - 4 line, 3CT	
esc	▼	▲
		enter

Nominal current

The nominal current specifies which value

- overcurrent,
 - current transients,
 - and automatic graphics scaling
- refer to.

Setting range: 0 .. 1,000,000 A

Transformer L1		
	primary	secondary
Current Transf.	100A	5A
Voltage Transf.	400V	400V
Rated Current	5000A	
Rated Voltage	230V	
apply to L2-L4	no	
Voltage con.	3 phase - 4 line, 3VT	
Current con.	3 phase - 4 line, 3CT	
esc	▼	▲
		enter



You can only set the nominal values for measurement of the K-Factor and TDD using EM-PQ VIS.

Configuration - measurement

Connection diagram for current measurement

You can select between the following connection diagrams for current measurement:

- 3p4w - 3 phase 4 conductor, 3 current conv.
- 3p5w - 3 phase 4 conductor, 4 current conv.
The fourth current transformer can be used for measuring the neutral conductor e.g.
- 3p2i - 3 phase 4 conductor, 2 current conv.
For networks under symmetric load.
- 3p2i0 - 3 phase 3 conductor, 2 current conv.
Aron connection for networks without a neutral conductor. The third current will be calculated.
- 1p2i - 1 Phasen 2 Leiter, 2 Stromwandler

Factory pre-setting: 3p4w



A connection diagram does not have to be configured for measurement inputs V4 and I4.

Transformer L1		
	primary	secondary
Current Transf.	100A	5A
Voltage Transf.	400V	400V
Rated Current	5000A	
Rated Voltage	230V	
apply to L2-L4	no	
Voltage con.	3 phase - 4 line, 3VT	
Current con.	3 phase - 4 line, 3CT	

esc ▾ ▲ enter

Transformer L1		
	primary	secondary
Current Tr		5A
Voltage Tr		400V
Rated Cur		
Rated Volt		
apply to L		
Voltage c		ne, 3VT
Current con.		3 phase - 4 line, 3CT

esc ▾ ▲ enter

Illu. Example for current measurement using 3 current converters in a 3 phase 4 conductor network.

Transients

Transient voltages are rapid, impulsive transient oscillation processes in electrical networks. Transient voltages are not predictable with respect to time and last for a limited period. Transient voltages are caused by the effects of lighting, due to switching operations or the triggering of fuses.

- The EM-PQ2500 recognizes transients that are longer than 50 μ s.
- The EM-PQ2500 monitors the voltage measurement inputs on transients.
- Transient monitoring can be set per phase.
- There are two independent criteria for recognizing transients.
- If a transient has been recognized, the wave shape is saved in a transient recording.
- If a transient has been recognized, the limit value is automatically increased by 20V, both in automatic and manual modes. This automatic increase of the limit value fades within 10 minutes.
- If another transient is recognized within the next 60 seconds, this transient is recorded with 512 points.
- You can display recorded transients with the EM-PQ VIS incident browser.

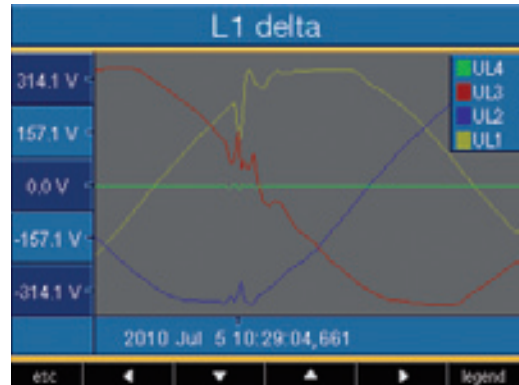

Configuration - measurement

Mode (absolute)

If a scanning value exceeds the set limit value, a transient is recognized.

- **Off**- Transient monitoring is switched off
- **Automatic**- Factory pre-setting. The limit value is automatically calculated and is 110% of the current 200 ms effective value.
- **Manual**- Transient monitoring uses the adjustable limit value under "Peak U".

Mode (delta)

If the difference of two neighbouring scanning points exceeds the set limit value, a transient is recognized.

- **Off**- Transient monitoring is switched off.
- **Automatic**- Factoring pre-setting. The limit value is calculated automatically and is 0.2175 times the current 200ms effective value.
- **Manual**- Transient monitoring uses the adjustable limit value under "Trns U".



Transienten L1		
Voltage		
Mode (abs)	manually	
Peak U	150%	(345.0V)
Mode (delta)	manually	
Trns U	150%	(345.0V)
apply to L2-L4	no	
esc ▾ ▲ enter		

Accept L2-L4

Transient monitoring can be set per phase. You can accept settings from phase L1 into phases L2, L3 and L4.

- **No** - The L1 phase settings are not transferred to the stages L2, L3 and L4.
- **Yes**- The settings from phase L1 are taken over into phases L2, L3 and L4.

Events

Events are limit value violations of effective current and voltage values.

The EM-PQ2500 compares the limit values with the full wave rms values (20ms/16.7ms) of current and voltage.

- You can specify limit values for each current input and each voltage input.
- The full wave effective values, average value, minimum or maximum value and the start time and end time of an incident are recorded.
- You can display recorded events with the EM-PQ VIS incident browser.
- The recording of full wave effective values is configured with EM-PQ VIS.

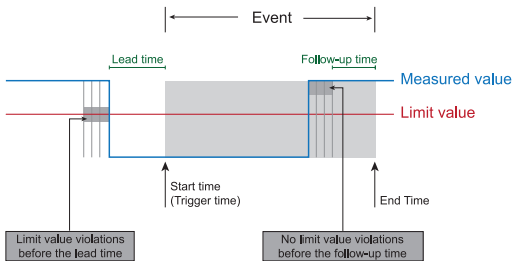

Measurement	
Events	
Phase L1	->
Phase L2	->
Phase L3	->
Phase L4	->
esc	enter

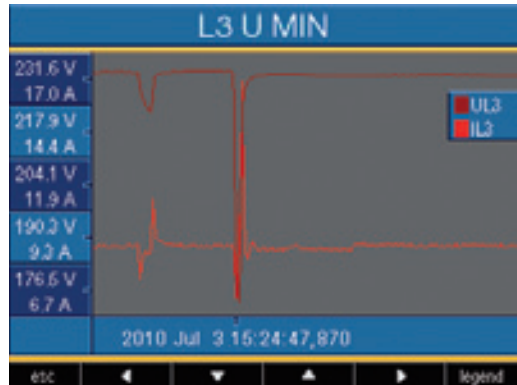

Illu. Display of the full wave effective values to an incident.

Voltage

Drop

A drop in voltage is set in % of the nominal voltage.

Overvoltage

The overvoltage is set in % of the nominal voltage.

Current

Overcurrent

The rapid increase of current is set in % of the nominal current.

Accept L2-L4

Monitoring of events can be set per phase. You can accept settings from phase L1 into phases L2, L3 and L4.

- **No-** Settings from phase L1 are **not** taken over into phases L2, L3 and L4.
- **Yes-** The settings from phase L1 are taken over into phases L2, L3 and L4.

Events L1		
Voltage		
Sag	85%	(195.5V)
Swell	110%	(253.0V)
Current		
Inrush	110%	(5500.0A)
apply to L2-L4	no	
esc		
▼		
▲		
enter		



Preparation time

The preparation time can only be set with EM-PQ VIS.
Factory pre-setting: 0



Follow-up time

The follow-up time can only be set with EM-PQ VIS.
Factory pre-setting: 0

Display

Brightness

The brightness level of the background illumination can be adjusted. The brightness level set here is used during operation of the EM-PQ2500.

Setting range: 0 .. 100%

Factory pre-setting: 70%

(0% = dark, 100% = very bright)

Standby

This refers to the time before the brightness changes to "standby brightness".

Setting range: 60 .. 9999 seconds

Factory pre-setting: 900 seconds

Standby brightness

This refers to the brightness level changed to after the end of the standby time. The standby time is restarted by using keys 1-6.

Setting range: 0 .. 60%

Factory pre-setting: 40%

Screensaver

The screensaver prevents a screen on the LCD from "sticking" if the screen does not change for a longer period of time.

Setting range: yes, no

Factory pre-setting: yes



Display	
Brightness	70%
Standby	9999s
Brightness(standby)	40%
Screen Saver	no
Screen Update	fast
Rotate	no
Rotation interval	0s

Presentation

You can specify the speed at which new measurement values should appear on the measurement value displays.

Setting range: fast (200ms),

slow (1s)

Factory pre-setting: fast

Rotate

The measurement value displays are automatically displayed in sequence. The configuration displays are not affected by this.

Setting range: yes, no

Factory pre-setting: no

Transition time

You can set the time between automatic transition to the next measurement value display.

Setting range: 0 .. 255 seconds

Factory pre-setting: 2 seconds



The service life of the background illumination extends if the brightness of the background illumination is kept lower.

System settings

Display of system settings specific to the device.

The screenshot shows a 'System' settings menu with the following items:

Setting	Value
Version	1.143
Serial	22000015
MAC	00:0E:6D:04:01:A3
Address	78.140.98.236
Gateway	78.140.98.233
Date/Time	05.08.2010 10:55:52
Password	0
Re-initialization	->

Labels on the left side of the image point to the following items:

- Firmware version (points to Version)
- Device serial number (points to Serial)
- Fixed device MAC address (points to MAC)
- Set IP address (points to Address)
- Set Gateway address (points to Gateway)
- Date and time (points to Date/Time)
- Set password (points to Password)
- Reset settings (points to Re-initialization)

Illu. Example for the display of system settings.



You cannot configure the date and time directly on the device. Settings for time synchronization and the date and time can only be made using EM-PQ VIS.

Password

The user can block access to the configuration with a password. Changing the configuration directly on the device is then only possible after entering the password.

The password consists of a 6 digit combination of numbers.

Setting range: 1-999999 = with password
000000 = without password

A password (000000) is not programmed in the factory.

- In order to change a set password, you must know the current password.
- Note any changed password.
- If you do not want a password request anymore, enter "000000" as a password.

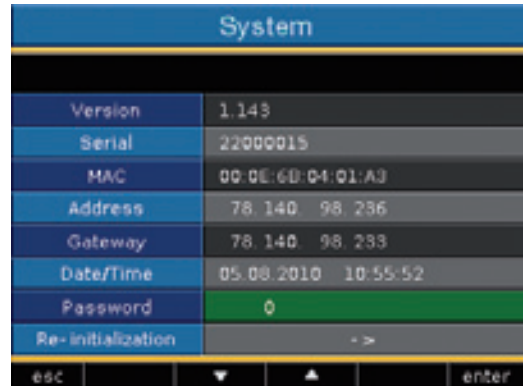

System	
Version	1.143
Serial	22000015
MAC	00 0E 6B 04 01 A3
Address	78.140.98.236
Gateway	78.140.98.233
Date/Time	05.08.2010 10:55:52
Password	0
Re-initialization	->

Forgotten password

If you have forgotten the password, you can only delete the password using the "EM-PQ VIS" software.

In order to do this, connect the EM-PQ2500 with the PC using a suitable interface. Further information can be found in the EM-PQ VIS assistant.

Delete minimum and maximum values

You can delete all minimum and maximum values in the EM-PQ2500 simultaneously.

How to delete the individual minimum and maximum values is described in the chapter "individually deleting min. and max. values".

Delete all minimum and maximum values.

- Select "yes" with key 3
- Confirm with key 6.
- The message "executed" appears in the line - all minimum and maximum values have been deleted.

Re-initialization			
Reset energie	no		
Clear min/max	no		
Delivery status	no		
Reset	no		
esc	▼	▲	enter

Delete power meters

You can delete all power meters in the EM-PQ2500 at the same time.

A selection of certain power meters is not possible.

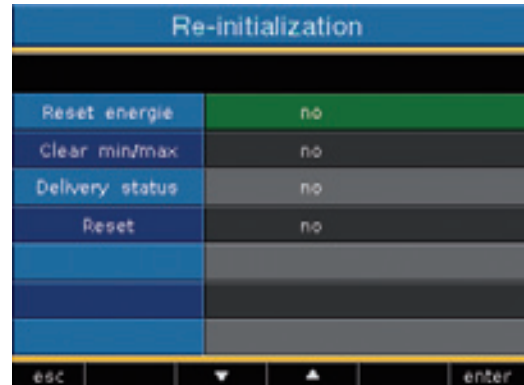

- Select with key 3 "yes"
- Confirm with key 6.
- The message "executed" appears in the line - all power meters have been deleted.



Configuration - system

Delivered condition

All settings such as the configuration and recorded data are reset to the factory pre-settings or deleted. Entered release codes are not deleted.

- Select with key 3 "yes"
- Confirm with key 6.
- The message "executed" appears in the line - the delivered condition is reinstored.

Re-initialization			
Reset energie	no		
Clear min/max	no		
Delivery status	no		
Reset	no		
esc	▼	▲	enter

Restart

The EM-PQ2500 restarts all programs.

- Select with the key 3 "yes".
- Confirm with key 6.
- The message "executed" appears in the line - all programs have been restarted.

Re-initialization			
Reset energie	no		
Clear min/max	no		
Delivery status	no		
Reset	no		
esc	▼	▲	enter

Configuration - system

Colors

Selection of colors for the presentation of current and voltage in the graphic presentations.



Extensions

Under "Extensions" you can subsequently release charged functions and show the status of basic programs.



The image shows a terminal-style configuration menu. At the top is a blue header bar with the text "Main menu". Below this is a black bar. The main content consists of a list of menu items, each with a colored background (blue or dark blue) and a corresponding value or action. The items are: "Language" (blue) with "English" (grey); "Communication" (dark blue) with "->" (grey); "Measurement" (blue) with "->" (grey); "System" (dark blue) with "->" (grey); "Display" (blue) with "->" (grey); "Colors" (dark blue) with "->" (grey); and "Extensions" (blue) with "->" (green). At the bottom, there is a black bar with four buttons: "esc", a downward arrow, an upward arrow, and "enter".

Main menu	
Language	English
Communication	->
Measurement	->
System	->
Display	->
Colors	->
Extensions	->

esc | ▼ | ▲ | enter

Release

The EM-PQ2500 contains chargeable functions that can be subsequently released.

List of release functions:

- BACnet
- EMAX

You receive the release code from the manufacturer. The manufacturer needs the device serial number and the name of function to be released. In order to release the function, you enter the 6 digit release code in the respective line.

Please note that the release code is only valid for one device.

Extensions	
Activation	->
Jasic-state	->

Extensions	
Activation	
BACnet	-1
EMAX	-1

Initialization

Applying the supply voltage

- The level of supply voltage for the EM-PQ2500 can be taken from the label.
- After applying the supply voltage, a startup screen appears on the display. Around ten seconds later, the EM-PQ2500 changes to the first measurement value display.
- If no display appears, you must check whether the supply voltage is within the nominal voltage range.

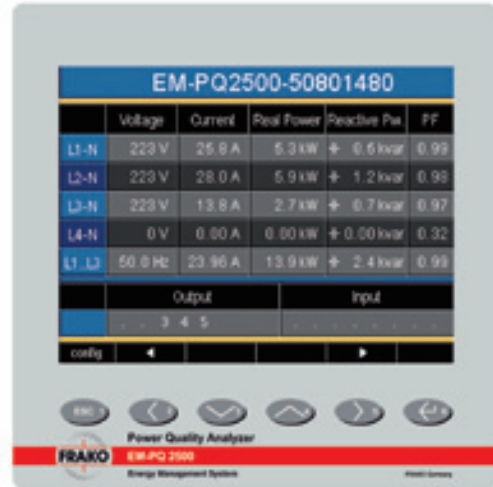

Warning!

Supply voltages that do not correspond with the details on the type label can lead to malfunctions and damage to the device.

Initialization

Apply measurement voltage

- Voltage measurements in networks with nominal voltages above 500VAC against ground must be connected using a voltage converter.
- After connection of the measurement voltages, the measurement values displayed by the EM-PQ2500 for voltages L-N and L-L must match those at the voltage measurement input.
- If a voltage converter factor is programmed, this must be considered upon comparison.

Rotary field direction

Check the direction of the voltage rotary field on the measurement value display of the EM-PQ2500.

A "right" rotary field is usually available.

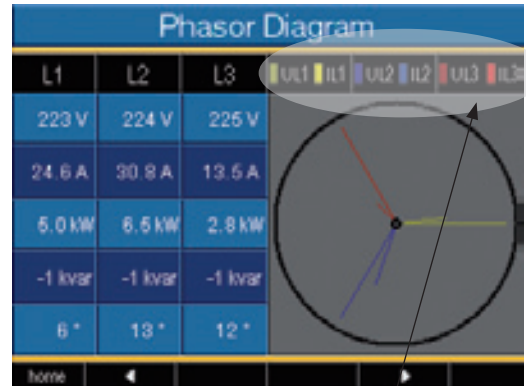

Presentation of the phase sequence according to the rotary field direction.

UL1-UL2-UL3 = right rotary field

UL1-UL3-UL2 = left rotary field



Warning!

The EM-PQ2500 is not suitable for measuring DC voltages.

Applying measurement current

The EM-PQ2500 is designed for the connection of $\dots/1A$ and $\dots/5A$ current converters.

Only AC currents, and not DC currents, can be measured using the current measurement inputs.

Short-circuit all current converter outputs except one. Compare the currents displayed by the EM-PQ2500 with the applied current.

The current displayed by the EM-PQ2500 must match the input current under consideration of the current converter transfer relation.

The EM-PQ2500 must display approx. zero amperes in the short-circuited current measurement inputs.

The current converter ratio is set to 5/5A in the factory and may have to be adapted to the current converter used.

Sign

Reactive power

- positive (+) with inductive load,
- negative (-) with capacitive load.

Phase angle (U/I)

- positive (+) with capacitive load,
- negative (-) with inductive load.

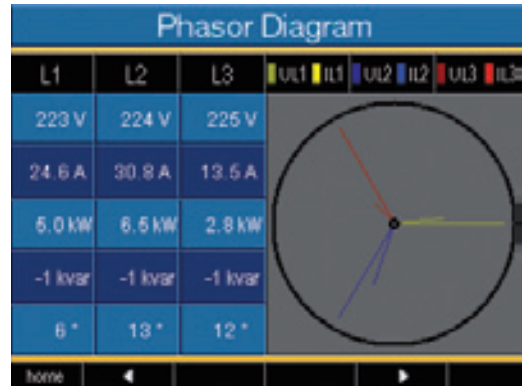

Voltages are shown with long pointers in the pointer diagram, and currents with shorter pointers.

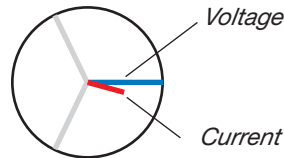

Warning!

Voltages and currents outside of the authorized measurement range can destroy the device.

Pointer diagram, example 1

Primarily ohmic load.

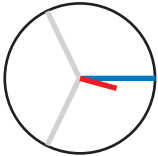

Voltage and current only have a minor difference in the phase.

- The current measurement input is allocated to the right voltage measurement input.

Pointer diagram, example 2

Primarily ohmic load.

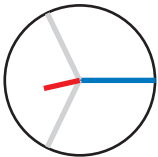

Voltage and current have a difference of approximately 180° in the phase.

- The current measurement input is allocated to the right voltage measurement input.
- In this current measurement, the connections **k and I are swapped over** or there is a return feed into the supplier network.

Checking the power measurement

Short-circuit all current converter outputs except one and check the displayed power outputs.

The EM-PQ2500 may only display one power output in the phase with the current converter input that is not short-circuited. If this does not apply, please check the connection of the measurement voltage and measurement current.

If the amount of effective power is correct but the sign of effective power is negative, this may have two causes:

- Connections S1(k) and S2(l) are mixed up on the current converter.
- Effective power is returned to the network.

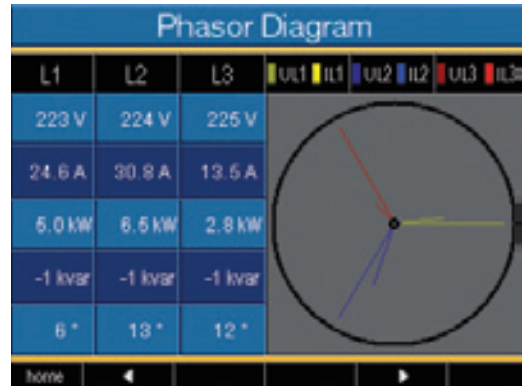

In the pointer diagram, voltages are shown with the longer pointers and currents with shorter pointers.

Initialization

Checking communication

The EM-PQ2500 counts all received (RX), all sent (TX) and all faulty data packages. In the ideal case, the number of errors shown in the error column is zero.

Reset

You can delete the counters for the data packages with key 6.

The start time for the recount is reset.

Communication State			
	RX	TX	Error
Ethernet	2225.0 k	2016.4 k	19240
RS485	0	0	0
NTP	0	0	0
DHCP	0	0	0
DNS	0	0	0
E-Mail	-	0	0
Start Time	05-07-2010 12:44:31		
home	◀		▶ reset

Profibus profile

A Profibus profile contains data to be exchanged between a device and an SPS. Four Profibus profiles are pre-configured in the factory.

With a Profibus profile, you can:

- call-up measurement values from the device,
- set the digital outputs in the device,
- request the status of the digital inputs in the device.

Each Profibus profile can contain a maximum of 127Bytes. You can apply further Profibus profiles if more data has to be transferred.

- Each Profibus profile has a profile number. The profile number is sent by the PLC to the device.
- You can directly process 16 Profibus profiles with EM-PQ VIS (profile numbers 0..15).
- Additional Profibus profiles (profile numbers 16..255) can be applied using Jasic programs.
- Factory pre-configured Profibus profiles can be subsequently changed.

Device master file

The device master file, abbreviated with GSD file, describes the Profibus characteristics of the EM-PQ2500. The GSD file is required by the PLC configuration program.

The device master file for the EM-PQ2500 has the file name "U5080C2C.GSD" and is contained on the data carrier supplied with the delivery.

Variable definition

All system variables and global variables¹⁾ can be scaled individually and converted into one of the following formats:

- 8, 16, 32Bit integer with and without sign.
- 32 or 64Bit float format.
- Big or Little Endian.

Big-Endian = High Byte before Low Byte.

Little-Endian = Low Byte before High Byte.

¹⁾Global variables are variables that are defined by the user in Jasic and are provided to each interface in the EM-PQ2500.

Example

Collect measurement values using Profibus

You must transfer at least one Profibus profile with EM-PQ VIS and transfer it to the EM-PQ2500.

A Jasic program is not necessary.

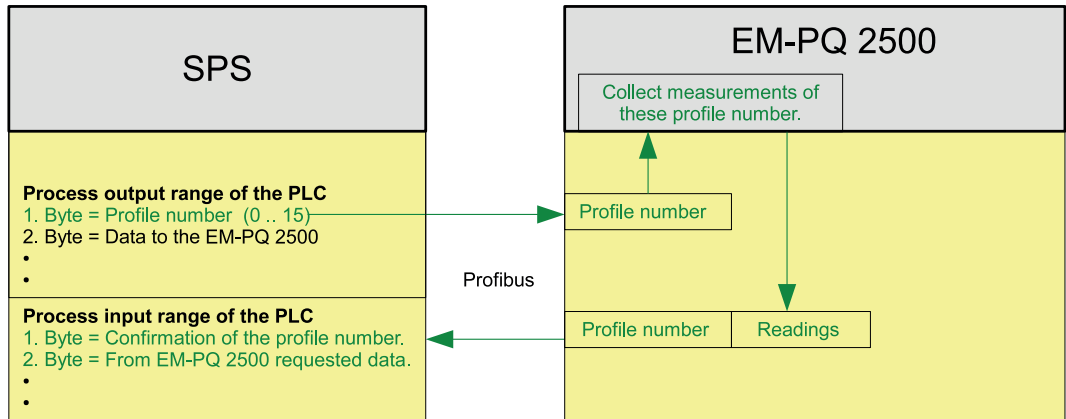

Illu. Block switch diagram for data exchange between PLC and EM-PQ2500.

Profibus

Profibus profile number 0

	Byte Index	Value type	Value format	Scaling
1	1	Voltage L1-N	float	1
2	5	Voltage L2-N	float	1
3	9	Voltage L3-N	float	1
4	13	Voltage L4-N	float	1
5	17	Voltage L2-L1	float	1
6	21	Voltage L3-L2	float	1
7	25	Voltage L1-L3	float	1
8	29	Current L1	float	1
9	33	Current L2	float	1
10	37	Current L3	float	1
11	41	Current L4	float	1
12	45	Effective power L1	float	1
13	49	Effective power L2	float	1
14	53	Effective power L3	float	1
15	57	Effective power L4	float	1
16	61	Cosphi (math.) L1	float	1
17	65	Cosphi (math.) L2	float	1
18	69	Cosphi (math.) L3	float	1
19	73	Cosphi (math.) L4	float	1
20	77	Frequency	float	1
21	81	Effective power total L1-L4	float	1
22	85	Reactive power L1-L4	float	1
23	89	Apparent power total L1-L4	float	1
24	93	Cosphi (math.) total L1-L4	float	1
25	97	Effective current total L1-L4	float	1
26	101	Effective consumption total L1-L4	float	1
27	105	Ind. reactive consum. total L1-L4	float	1
28	109	THD voltage L1	float	1
29	113	THD voltage L2	float	1
30	117	THD voltage L3	float	1
31	121	THD voltage L4	float	1

Profibus profile number 1

	Byte-Index	Value type	Values-format	Scaling
1	1	Voltage L1-N	Float	1
2	5	Voltage L2-N	Float	1
3	9	Voltage L3-N	Float	1
4	13	Voltage L2-L1	Float	1
5	17	Voltage L3-L2	Float	1
6	21	Voltage L1-L3	Float	1
7	25	Current L1	Float	1
8	29	Current L2	Float	1
9	33	Current L3	Float	1
10	37	Effective power L1	Float	1
11	41	Effective power L2	Float	1
12	45	Effective power L3	Float	1
13	49	Cosphi (math.) L1	Float	1
14	53	Cosphi (math.) L2	Float	1
15	57	Cosphi (math.) L3	Float	1
16	61	Frequency	Float	1
17	65	Effective power total L1-L3	Float	1
18	69	Reactive power total L1-L3	Float	1
19	73	Apparent power total L1-L3	Float	1
20	77	Cosphi (math.) total L1-L3	Float	1
21	81	Effective current total L1-L3	Float	1
22	85	Effective consumption total L1-L3	Float	1
23	89	Ind. Reactive consum. total L1-L3	Float	1
24	93	THD voltage L1	Float	1
25	97	THD voltage L2	Float	1
26	101	THD voltage L3	Float	1
27	105	THD current L1	Float	1
28	109	THD current L2	Float	1
29	113	THD current L3	Float	1

Profibus

Profibus profile number 2

	Byte-Index	Value type	Values-Format	Scaling
1	1	Effective consumption total L1-L3	Float	1
2	5	Drawn eff. consum. total L1-L3	Float	1
3	9	Supplied eff. consum. total L1-L3	Float	1
4	13	Reactive consumption total L1-L3	Float	1
5	17	Ind. reactive consum. total L1-L3	Float	1
6	21	Cap. reactive consum. total L1-L3	Float	1
7	25	Apparent consumption total L1-L3	Float	1
8	29	Effective consumption L1	Float	1
9	33	Effective consumption L2	Float	1
10	37	Effective consumption L3	Float	1
11	41	Inductive reactive consumption L1	Float	1
12	45	Inductive reactive consumption L2	Float	1
13	49	Inductive reactive consumption L3	Float	1

Profibus profile number 3

	Byte-Index	Value type	Values-Format	Scaling
1	1	Effective power L1	Float	1
2	5	Effective power L2	Float	1
3	9	Effective power L3	Float	1
4	13	Effective power total L1-L3	Float	1
5	17	Current L1	Float	1
6	21	Current L2	Float	1
7	25	Current L3	Float	1
8	29	Current total L1-L3	Float	1
9	33	Effective consumption total L1-L3	Float	1
10	37	CosPhi (math.) L1	Float	1
11	41	CosPhi (math.) L2	Float	1
12	45	CosPhi (math.) L3	Float	1
13	49	CosPhi (math.) total L1-L3	Float	1
14	53	Reactive power L1	Float	1
15	53	Reactive power L2	Float	1
16	53	Reactive power L3	Float	1
17	53	Reactive power total L1-L3	Float	1
18	53	Apparent power L1	Float	1
19	53	Apparent power L2	Float	1
20	53	Apparent power L3	Float	1
21	53	Apparent power total L1-L3	Float	1

Service and Maintenance

The device is subjected to different safety tests before delivery and marked with a seal. If a device is opened, the safety tests have to be repeated. A guarantee is only provided for unopened devices.

Repair and Calibration

Repair work and calibration can only be undertaken by the manufacturer.

Front film

Cleaning the front film can be done with a soft cloth and domestic detergent. Acids and products containing acids may not be used for cleaning.

Battery

The internal clock is fed from the supply voltage. If the supply voltage fails, the clock is supplied by the battery. The clock provides the date and time information, e.g. for recordings, minimum and maximum values and events.

The expected battery life is at least 5 years at a storage temperature of +45°C. The typical battery life is 8 to 10 years.

The device must be opened to exchange the battery. If the device has been opened, a new safety test is required for safe operation. A guarantee is only provided for unopened devices.

Disposal

The EM-PQ2500 can be recycled as electronic scrap in accordance with the legal regulations. The fixed, integrated lithium battery must be disposed of separately.

Firmware update

If a firmware update has to be carried out for your EM-PQ2500, you can do this with the EM-PQ VIS software included in the delivery.

Service

Should any questions arise that are not described in this handbook please contact the manufacturer directly.

We will require the following compulsory details from you for processing:

- Device name (refer to label),
- Serial number (refer to label),
- Software release (refer to measurement value display),
- Measurement voltage and supply voltage,
- Precise error description.

Service and Maintenance

Procedure in case of errors

Possible error	Cause	Remedy
None Display .	External fuse for the supply voltage has triggered.	Replace fuse.
None Current display .	The measurement voltage is not connected. The measurement current is not connected.	Connect measurement voltage. Connect measurement current.
Displayed current is too high or low.	Current measurement is in the wrong phase. Current converter factor is incorrectly programmed.	Check connection and correct if necessary. Read current converter transfer ratio on the current converter and program it.
Displayed voltage is too low or high	Measurement in the wrong phase. Voltage converter is incorrectly programmed.	Check connection and correct if necessary. Read voltage converter transfer ratio on the voltage converter and program it.
Displayed voltage is too light.	Measurement range exceeded. The voltage peak at the measurement input has been exceeded due to harmonics.	Use a voltage converter. Warning! It is necessary to make sure that the measurement inputs are not overloaded.

Service and Maintenance

Possible errors	Cause	Remedy
Effective power is too high or low.	The programmed current converter transfer ratio is wrong.	Read and program the current converter transfer ratio on the current converter.
	The current path is allocated to the wrong voltage path. The programmed voltage converter transfer ratio is wrong.	Check the connection and correct if necessary. Read and program the current converter transfer ratio on the current converter.
Effective power-receipt/supply are mixed up.	At least one current converter connection is mixed up.	Check and correct the connection if necessary.
	A current path is allocated to the wrong voltage path.	Check and correct the connection if necessary.
No connection to device.	RS485: - Wrong device address. - Different bus speeds	Set device address. Check and correct the speed (baudrate)
	- Wrong protocol. - Termination is missing.	Select protocol. Connect bus with terminating resistor (120 Ohm).
	Ethernet: - IP address is wrong	Set IP address on the device.
The device does not work despite taking the above measures.	Device is defective.	Send the device to the manufacturer to check with an exact description of the error.

Technical data

General

Net weight	: 1080g
Device dimensions	: approx. l=144mm, w=144mm, h=75mm
Battery	: Type VARTA CR1/2AA, 3 V, Li-Mn
Service life of background illumination	: 40000h (50% of initial brightness)

Transport and storage

The following details apply to devices transported or stored in the original packaging.	
Free fall	: 1m
Temperature	: K55 (-25°C to +70°C)
Relative air humidity	: 0 to 90 % RH

Technical data

Environmental conditions in operation

The EM-PQ2500 is intended for use in a weather-protected, fixed extradata.

The EM-PQ2500 must be connected to the protective wire connection! Protection class I according to IEC 60536 (VDE 0106, part 1).

Calculation temperature range	: K55 (-10°C .. +55°C)
Relative air humidity	: 0 to 75 % RH
Operating height	: 0 .. 2000m above sea level
Impurity level	: 2
Installation extradata	: any
Ventilation	: external ventilation is not required.
Foreign matter and water protection,	
Front	: IP50 according to EN60529
Reverse side	: IP20 according to EN60529

Supply voltage

Installation overvoltage category	: II
Safeguarding of supply voltage	
Circuit breaker	: 6A typ C (approved by UL/IEC)
230V	
Nominal range	: 95V .. 240V (45-65Hz) or DC 80V .. 340V
Working range	: +/-10% of nominal range
Power consumption	: max. 10W, max. 15VA

Connection capacity of terminal points

Connectable conductors. Only one conductor per terminal point may be connected!

Single wire, multi-wire, fine wire	: 0.2 - 2.5mm ² , AWG 24 - 12
Pin terminals, ferrules	: 0.25 - 2.5mm ²
Tightening torque	: 0.5 - 0.6 Nm,
Insulation length	: 7mm

Inputs and outputs

8 digital inputs

Maximum counting frequency	: 20Hz
Reaction time (Jasic program)	: 200ms
Input signal applied	: 18V .. 28V DC (typical 4mA)
Input signal not applied	: 0 .. 5V DC, current lower than 0.5mA

5 digital outputs, semi-conductor relay, not short-circuit proof.

Switch voltage	: max. 60V DC, 30V AC
Switch current	: max. 50mAeff AC/DC
Reaction time (Jasic program)	: 200ms
Output of voltage drops	: 20ms
Output of voltage excesses	: 20ms
Impulse output (power impulse)	: max. 20Hz

Line length	: up to 30m - not shielded
	: larger than 30m - shielded

Connection capacity of terminal points

Rigid/flexible	: 0.14 - 1.5mm ² , AWG 28-16
Flexible with ferrules without plastic sleeve	: 0.25 - 1.5mm ²
Flexible with ferrules with plastic sleeve	: 0.25 - 0.5mm ²
Tightening torque	: 0.22 - 0.25Nm
Insulation length	: 7mm

Measurement inputs

Voltage measurement

The voltage measuring inputs are suitable for the following grids of power supply:

Three-phase 4 conductor systems L-N/L-L	: 417V/720V (+10%)
Three-phase 3 conductor systems L-L	: 600V (+10%)

The voltage measuring inputs regarding safety and reliability reasons are dimensioned as follows:

Overvoltage category	: 600V CAT III
Measurement surge voltage	: 6kV

Measuring range L-N	: 0 ¹⁾ .. 600Vrms
Measuring range L-L	: 0 ¹⁾ .. 1000Vrms
Resolution	: 0.01V
Crest factor	: 1,6 (relating to 600Vrms)
Impedance	: 4M Ω /Phase
Power consumption	: ca. 0.1 VA
Scanning frequency	: 20kHz/phase
Transients	: >50 μ s
Frequency of fundamental oscillation	: 40Hz .. 70Hz
Resolution	: 0.001Hz

¹⁾The EM-PQ2500 can only detect measurement values if a voltage L-N larger than 10V_{eff} or a voltage L-L larger than 18V_{eff} is applied to at least one voltage measurement input.

Current measurement

Rated current	: 5A
Resolution	: 0,1mA
Measuring range	: 0,001 .. 8,5Arms
Crest factor	: 2,4
Overvoltage category	: 300V CAT III
Measurement surge voltage	: 4kV
Power consumption	: ca. 0.2 VA, (Ri=5mOhm)
Overload for 1 second	: 120A (sinusoidal)
Scanning frequency	: 20kHz

Connection capacity of terminal points

Connectable conductor (current measurement and voltage measurement). Only one conductor per terminal point may be connected!

Single wire, multi-wire, fine wire	: 0.2 - 2.5mm ² , AWG 24 - 12
Pin terminals, ferrules	: 0.25 - 2.5mm ²
Tightening torque	: 0.5 - 0.6Nm,
Insulation length	: 7mm

Technical data

Specifications

(Measurement using current converters ../5A)

Network quality parameters

Function	Symbol	Accuracy class	Measur. range	Display range
Frequency	f	0.05 (IEC61557-12)	40 .. 70 Hz	40 Hz .. 70 Hz
Phase current	I	0.2 (IEC61557-12)	0.001 .. 8.5 Arms	0 A .. 9999 kA
Neutral cond. current measured	IN	0.2 (IEC61557-12)	0.001 .. 8.5 Arms	0 A .. 9999 kA
Neutral cond. current calculated	INc	0.5 (IEC61557-12)	0.001 .. 25.5 A	0 A .. 9999 kA
Voltage	U L-N	0.1 (IEC61557-12)	10 .. 600 Vrms	0 V .. 9999 kV
Voltage	U L-L	0.1 (IEC61557-12)	18 .. 1000 Vrms	0 V .. 9999 kV
Short-time flicker, long-time fli.	Pst, Plt	-	-	-
Voltage drops (L-N)	Udip	0.2 (IEC61557-12)	10 .. 600 Vrms	0 V .. 9999 kV
Voltage rises (L-N)	Uswl	0.2 (IEC61557-12)	10 .. 600 Vrms	0 V .. 9999 kV
Voltage interruptions	Uint	-	-	-
Voltage unbalance (L-N) ¹⁾	Unba	0.2 (IEC61557-12)	10 .. 600Vrms	0 V .. 9999 kV
Voltage inbalance (L-N) ²⁾	Unb	0.2 (IEC61557-12)	10 .. 600 Vrms	0 V .. 9999 kV
Voltage harmonics	Uh	cl. 1 (IEC61000-4-7)	to 2.5 kHz	0 % .. 100 %
Current harmonics	Ih	cl. 1 (IEC61000-4-7)	to 2.5 kHz	0 % .. 100 %
Network signal voltage	MSV	-	-	-

1) Reference to amplitude.

2) Reference to phase and amplitude.

Technical data

Function parameters

Function	Symbol	Accuracy class	Measurem. range	Display range
Total effective power	P	0.2 ⁵⁾ (IEC61557-12)	0 .. 15.3kW	0 W .. 9999 GW
Total reactive power	QA, Qv	1 (IEC61557-12)	0 .. 15.3 kvar	0 varh .. 9999 Gvar
Total apparent power	SA, Sv	0.2 ⁵⁾ (IEC61557-12)	0 .. 15.3 kVA	0 VA .. 9999 GVA
Total effective energy	Ea	0.2 ⁵⁾ (IEC61557-12)	0 .. 15.3 kWh	0 Wh .. 9999 GWh
Total reactive energy	ErA, ErV	1 (IEC61557-12)	0 .. 15.3 kvarh	0 varh .. 9999 Gvarh
Total apparent energy	EapA, EapV	0.2 ⁵⁾ (IEC61557-12)	0 .. 15.3 kVAh	0 VAh .. 9999 GVAh
Frequency	f	0.05 (IEC61557-12)	40 .. 70 Hz	40 Hz .. 70 Hz
Phase current	I	0.2 (IEC61557-12)	0.001 .. 8.5 Arms	0 A .. 9999 kA
Neutral cond. current measured	IN	0.2 (IEC61557-12)	0,001 .. 8.5 Arms	0 A .. 9999 kA
Neutral cond. current calculated	INc	0.5 (IEC61557-12)	0.001 .. 25.5 A	0 A .. 9999 kA
Voltage	U L-N	0.1 (IEC61557-12)	10 .. 600 Vrms	0 V .. 9999 kV
Voltage	U L-L	0.1 (IEC61557-12)	18 .. 1000 Vrms	0 V .. 9999 kV
Power factor	PFA, PFV	0.2 (IEC61557-12)	0.00 .. 1.00	0 .. 1
Short-time flicker, long-time fl.	Pst, Plt	-	-	-
Voltage drops	Udip	0.2 (IEC61557-12)	10 .. 600 Vrms	0 V .. 9999 kV
Voltage rises	Uswl	0.2 (IEC61557-12)	10 .. 600 Vrms	0 V .. 9999 kV
Transient overvoltages	Utr	0.2 (IEC61557-12)	10 .. 600 Vrms	0 V .. 9999 kV
Voltage interruptions	Uint	-	-	-
Voltage imbalance ¹⁾	Unba	0.2 (IEC61557-12)	10 .. 600 Vrms	0 V .. 9999 kV
Voltage imbalance ²⁾	Unb	0.2 (IEC61557-12)	10 .. 600 Vrms	0 V .. 9999 kV
Voltage harmonics	Uh	cl. 1 (IEC61000-4-7)	to 2.5 kHz	0 V .. 9999 kV
THD of voltage ³⁾	THDu	1.0 (IEC61557-12)	to 2.5 kHz	0 % .. 999 %
THD of voltage ⁴⁾	THD-Ru	1.0 (IEC61557-12)	to 2.5 kHz	0 % .. 999 %
Current harmonics	Ih cl.	1 (IEC61000-4-7)	to 2.5 kHz	0 A .. 9999 kA
THD of current ³⁾	THDi	1.0 (IEC61557-12)	to 2.5 kHz	0 % .. 999 %
THD des Stromes ⁴⁾	THD-Ri	1.0 (IEC61557-12)	to 2.5 kHz	0 % .. 999 %
Mains signal voltage	MSV	-	-	-

1) Reference to amplitude.

2) Reference to phase and amplitude.

3) Reference to basic oscillation.

4) Reference to effective value.

5) Accuracy class 0.2 with ../5A converter.

Accuracy class 0.5 with ../1A converter.

Serial interfaces

RS485	: plug, SUB D 9-pole
Protocol, Modbus RTU	: Modbus RTU/Slave, Modbus RTU/Master
Transfer rate	: 9.6kbps, 19.2kbps, 38.4kbps, 57.6kbps, 115.2kbps, 921.6kbps
Protocol, Profibus	: Profibus DP/V0 according to EN 50170
Transfer rate	: 9.6kBaud to 12MBaud
Ethernet 10/100Base-TX	
Connection	: RJ-45
Functions	: Modbus Gateway, Embedded Webserver (HTTP)
Protocols	: TCP/IP, EMAIL (SMTP), DHCP-Client (BootP), Modbus/TCP, Modbus RTU over Ethernet, FTP, ICMP (Ping), NTP, TFTP, SNMP.

Declaration of Conformity

The EM-PQ2500 fulfils the following protection requirements:

Directive 2004/108/EG in connection with DIN EN61326-1 (2006-10) as well as directive 2006/95/EG in connection with EN 61010-1 (2002-08)

Safety requirements

Safety requirements for electrical instrumentation, control and laboratory equipment
: EN 61010-1 08:2002, IEC 61010-1:2001

Noise immunity

DIN EN 61326-1:2006-10	Electrical equipment for measurement, control and laboratory use EMC requirements. Class A: Industrial environment
DIN EN 61000-4-2:2001-12	Electrostatic discharge 4kV/8kV
DIN EN 61000-4-3:2008-06	Electromagnetic RF Field 80-2700MHz
DIN EN 61000-4-4:2005-07	Burst immunity 1kV/2kV
DIN EN 61000-4-5:2007-06	Surge immunity 1kV/2kV
DIN EN 61000-4-6:2008-04	Conducted disturbances 3V
DIN EN 61000-4-8:2001-12	Power frequency magnetic field, 100A/m;
DIN EN 61000-4-11:2005-02	Voltage dips / short interruptions

Noise emission

DIN EN 61326-1:2006-10	Electrical equipment for measurement, control and laboratory use – EMC requirements: Class B: residential, commercial and light industrial environment.
DIN EN 61326-1 / 7.2 (CISPR 11)	Radio disturbance field strength 30MHz – 1GHz
DIN EN 61326-1 / 7.2 (CISPR 11)	Radio disturbance voltage 0,15MHz – 30MHz

Dimensioned drawings

Cutout size: $138^{+0,8} \times 138^{+0,8}$ mm

Reverse side



Patch cable

Side view

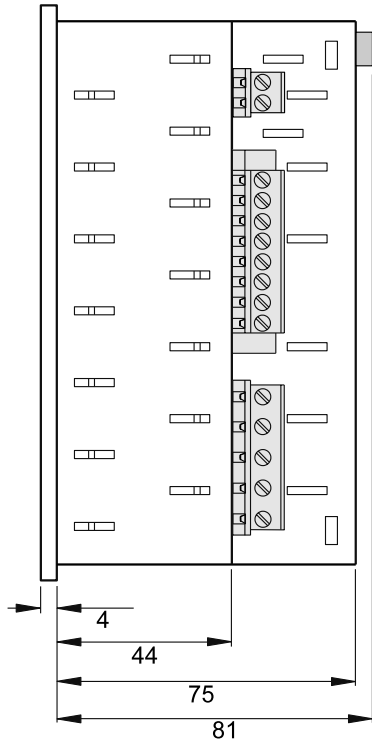

View from below

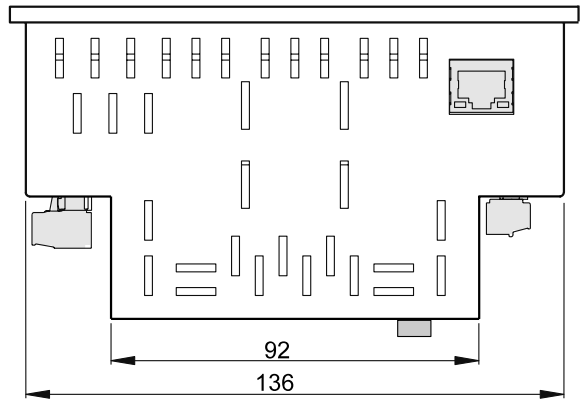

Configuration overview

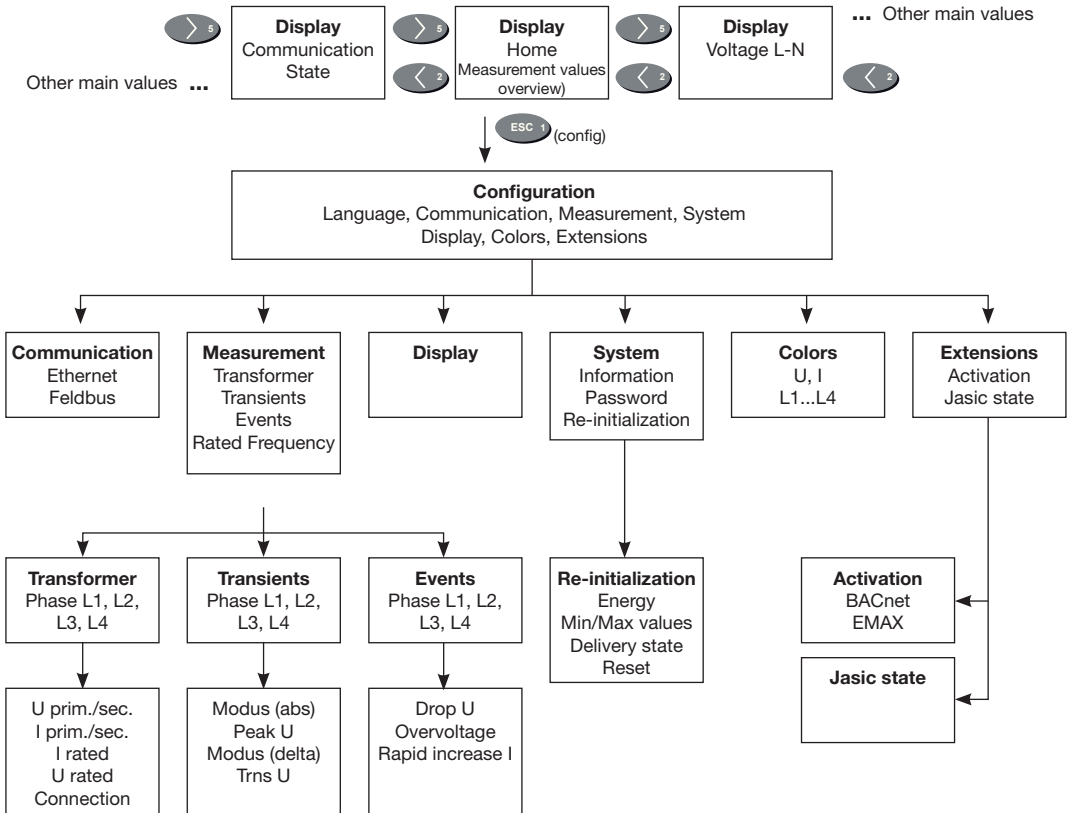

Configuration overview

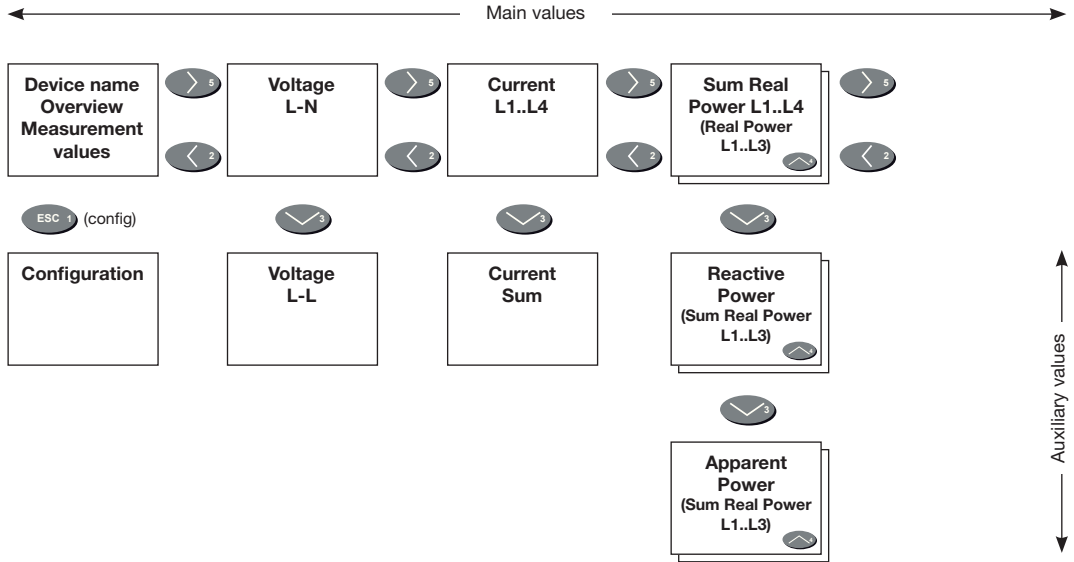

Measurement value displays overview

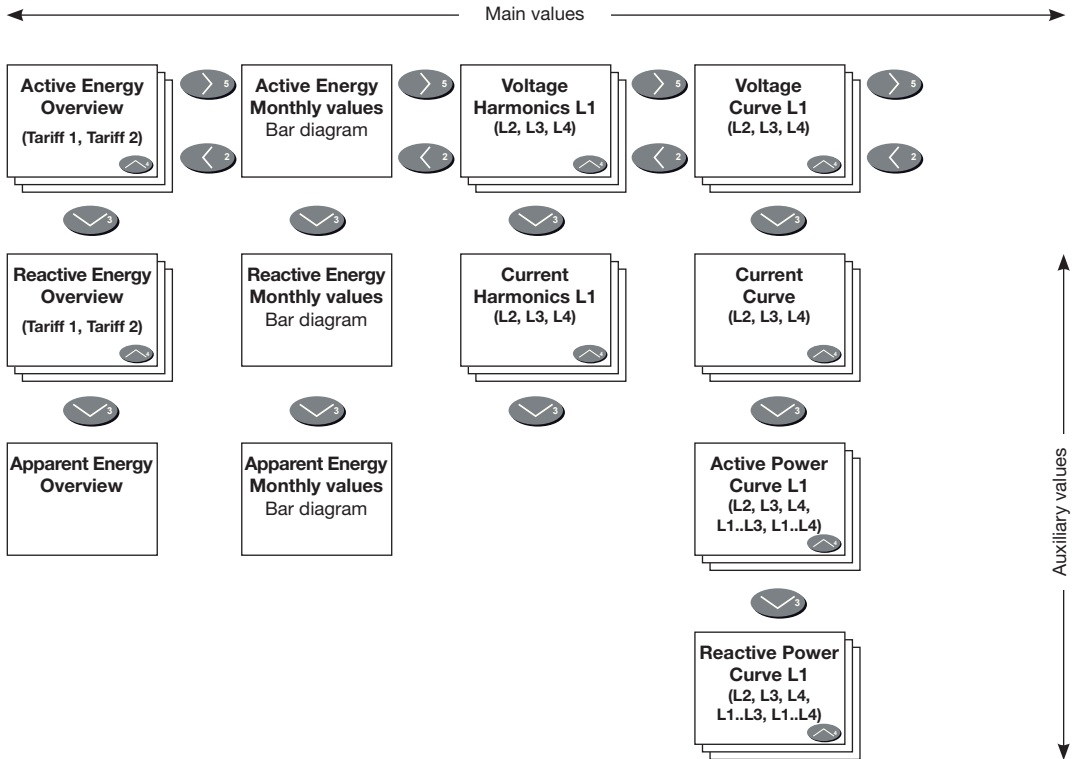

Measurement value displays overview

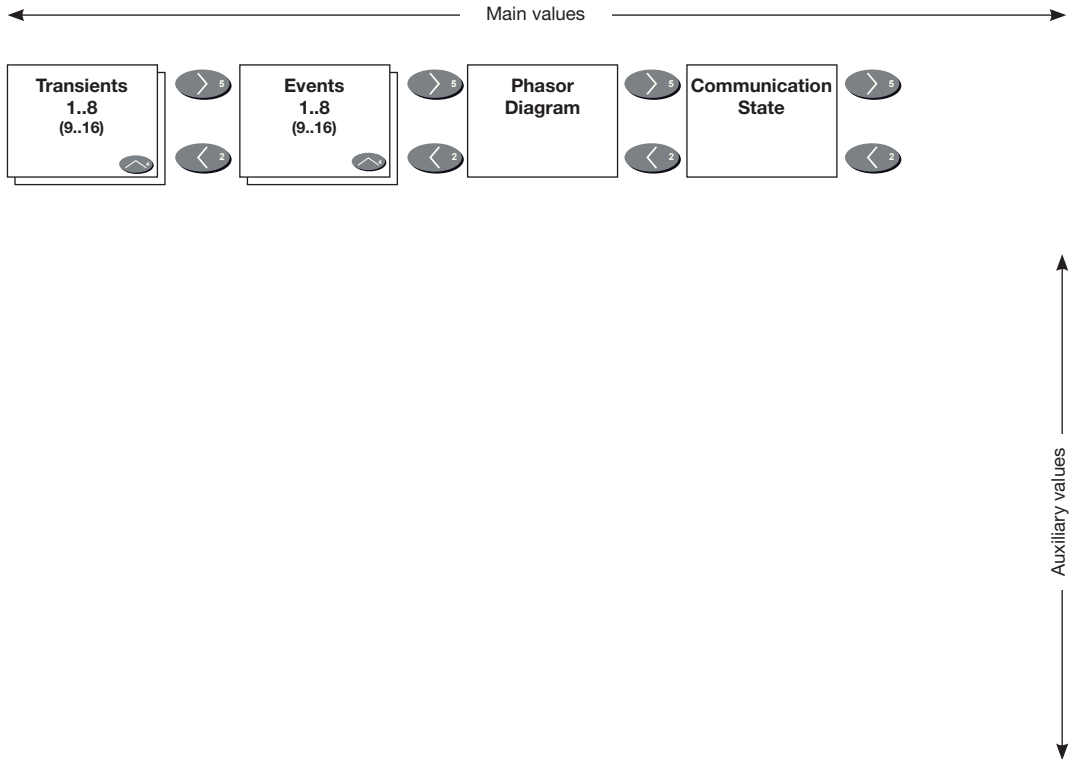

Connection example

