

Reactive Power Control Relay

RM 2106 / 2112

Operating Instructions



Info / Error

- i=0 No current
- A1 Switching sequence
- A2 No standard connection, connected internally
- E1 Defective capacitor
- E2 Wrong connection
- E3 No capacitors
- E4 Harmonic overcurrent
- E5 Cannot reach target PF

Setup

- 1- Target PF
- 2- Max. harmonic overcurrent
- 3- Alarm output at relay 12
- 4- Auto c/k
- 5- c/k value
- 6- Switching sequence
- 7- Service

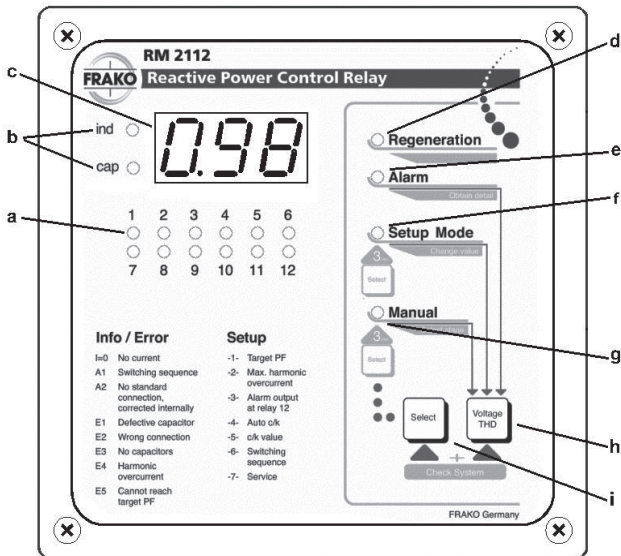

Figure 1 Front view

- | | |
|---|--|
| <p>a Display for active capacitor stages</p> <p>b Display for inductive or capacitive operating status</p> <p>c Digital displays</p> <p>d LED indicates regenerative power</p> <p>e Display for current or historical alarms</p> | <p>f LED lights up in setup mode</p> <p>g LED lights up in manual mode</p> <p>h Multifunctional button
(see operating instructions)</p> <p>i Selection key for manual mode, setup mode or automatic mode</p> |
|---|--|

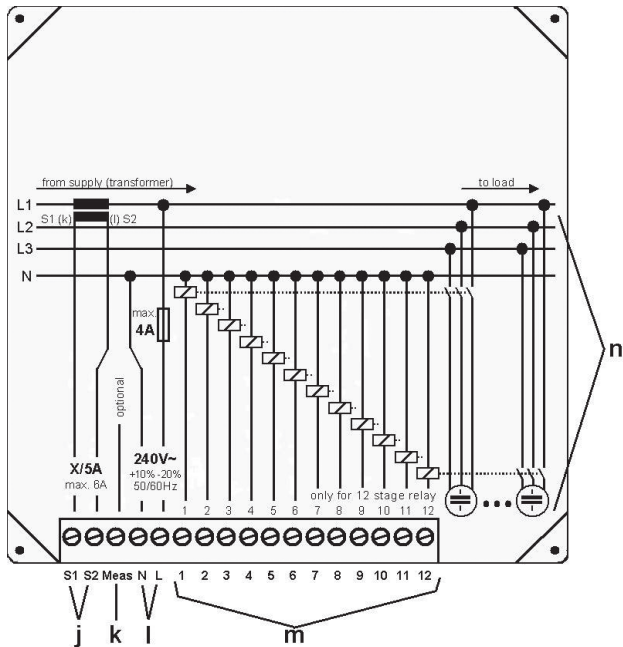

Figure 2 Rear view

- j** Connection for the current transformer
- k** Optional connector for improved measurement of harmonic wave
- l** Connector for power supply to the control relay

- m** Connectors for the control contacts that switch the contactors. The shared pole is connected to terminal 'L'.
- n** Typical connection

Table of Contents

1	Introduction	9			
1.1	How to use these operating instructions	9	4.4	Automatic response current identification -4-	28
1.2	Scope of functions	9	4.5	Response current -5-	28
			4.6	Relative value of the switch outputs -6-	30
2	Installation and connection	11	4.7	Service -7-	31
2.1	Installation	11	5	Functioning and operation	33
2.2	Voltage connection	11	5.1	Automatic control mode	33
2.3	Current transformer connection	12	5.2	Displaying the total harmonic distortion factor	33
2.4	"Meas" measuring voltage connection	12	5.3	Check System	33
2.5	Switching contacts	12	5.4	Manual mode	34
2.6	Alarm contact	13	6	Alarms and troubleshooting	35
2.7	Single phase connection	14	6.1	Connection errors	35
2.8	Extended connection	15	6.1.1	E3 - No capacitors	35
2.9	Connection with voltage transformer	16	6.1.2	E1 - Defect capacitor stages	35
2.10	Connection in special cases	17	6.1.3	E2 - Incorrect connection	35
			6.1.4	I = 0 - No current in current path	36
3	Start-up	19	6.2	Connection messages	36
3.1	Initial start-up	19	6.2.1	A2 - Incorrect connection that can be corrected internally	36
3.2	Subsequent start-up	20	6.2.2	A1 - Relative value of the switch output	36
3.3	Maintenance	21	6.3	Alarms in automatic control operation	36
4	Control relay setup	23	6.3.1	E4 - Harmonic overcurrent in the capacitor	37
4.1	Target power factor setting -1-	25			
4.2	Overcurrent switch off -2-	27			
4.3	Switching contact as alarm contact -3-	27			

6.3.2	E5 - Target power factor not reached	37
6.3.3	E1 - Defect capacitor stages	37
6.3.4	U = 0 - No measuring voltage	37
6.4	I = 0 - No measuring current	37
6.5	Other errors	38
7	Trouble-Shooting	39
8	Technical Data	41



**Safety and Warning Notices.
Important !
Read this before commissioning !**

- The operating instructions should be read carefully before the device is assembled, installed and put into operation.
- Installation and commissioning should only be carried out by appropriate specialists in accordance with existing regulations and provisions
- The operator must ensure that all operatives are familiar with these operating instructions and proceed accordingly
- The device conducts mains voltage and should not be opened
- If the device is obviously damaged, it should not be installed, connected or commissioned
- If the device does not work after commissioning, it should be disconnected from the mains again
- Any other laws, standards, guidelines, etc. regarding this product must be observed

The commissioning and safety information for the power factor correction system should also be observed.

EG-Konformitätserklärung

Declaration of Conformity



Dokument-Nr. EG-RM 2106_RM 2112-3004A / 11.2009
Document-No. CE-RM 2106_RM 2112-3004A / 11.2009

Wir/Wir: **FRAKO Kondensatoren- und Anlagenbau GmbH**
Tascheulinstraße 21 a
79331 Teningen
GERMANY

erklären in alleiniger Verantwortung, dass das Produkt
Declare under our sole responsibility that the product

Produktbezeichnung: Blindleistungsregler
name of product Reactive Power Regler

Typenreihe: **RM 2106 / RM 2112** ab Fert.-Nr. SN 00001
family from Ser. No.

auf das sich diese Erklärung bezieht, mit der/den folgenden Norm(en) oder normativen Dokument(en) übereinstimmt.
to which this declaration relates is in conformity with the following standard(s) or other normative document(s):

- EN 61000-6-3 2007-09 EMV, Fachgrundnorm Störaussendung - Wohnbereich, Geschäfts- und Gewerbebereiche
EMC, Emission standard for residential, commercial and light-industrial environments
EN 61000-6-4 2007-09 EMV, Fachgrundnorm Störaussendung Industriebereich
EMC, Emission standard for industrial environments
EN 61000-6-1 2007-10 EMV, Fachgrundnorm Störfestigkeit - Wohnbereich, Geschäfts- und Gewerbebereiche
EMC, Immunity for residential, commercial and light-industrial environments
EN 61000-6-2 2006-03 EMV, Fachgrundnorm Störfestigkeit Industriebereich
EMC, Immunity for industrial environments

gemäß den Bestimmungen der Richtlinien / *following the provisions of Directive*
2004/108/EG Elektromagnetische Verträglichkeit / *Electromagnetic Compatibility Directive*

- EN 61010-1 2004-01 Sicherheitsbestimmungen für elektrische Meß-, Steuer-, Regel- und Laborgeräte – Teil 1:
Allgemeine Anforderungen
Safety requirements for electrical equipment for measurement, control and laboratory use
- Part 1: *General requirements*

gemäß den Bestimmungen der Richtlinien / *following the provisions of Directive*
2006/95/EG Niederspannungsrichtlinie / *Low Voltage Directive*

Teningen, 16. November 2009



Peter Herbst

Diese Erklärung bescheinigt die Übereinstimmung mit den genannten Richtlinien, beinhaltet jedoch keine Zusicherung von Eigenschaften. Die Sicherheitshinweise der mitgelieferten Produktdokumentation sind zu beachten.
This declaration certifies conformity with the above-mentioned Directives, but does not contain any assurance of properties. Please observe the safety instructions of the attached product documentation.

1 Introduction

The reactive power control relay RM 2112 and RM 2106 respectively is capable of measuring the reactive power and active power of the connected mains network. Working in conjunction with a power factor correction system, the device controls the programmed target power factor by activating or deactivating capacitors.

1.1 How to use these operating instructions

	Important:
It is essential that you read section 2 "Installation and connection" and section 3 „Start-up“ before installing the control relay.	

The functions of the control relay are also described in brief in **section 1.2 „Scope of functions“**.

The setting options for the control relay are described in **section 4 „Control relay setup“**.

Section 5 „Functioning and operation“ explains how the control relay works and how to operate it.

Section 6 „Alarms and troubleshooting“ describes alarms and error messages of the control relay. Troubleshooting information is also provided there.

1.2 Scope of functions

Below is a brief overview of the various functions of the device:

- 12 switching contacts at RM 2112 and 6 switching contacts at RM 2106
- Power factor display
- Total harmonic distortion factor display (voltage thd)
- Semi-automatic connection detection
- Automatic detection of the capacitor stages
- Comprehensive connection analysis
- Patented characteristic avoiding overcompensation for low active power
- Four-quadrant regulation
- Cyclic switching of all capacitor stages of the same capacity
- Reactive power requirement-dependent switching delay time
- Optional monitoring of the harmonic overcurrent in the capacitor
- Deactivation at zero voltage or zero current
- Alarm signals for:
 - failure to reach the target power factor
 - overcurrent in the capacitor
 - defects at capacitor stages

2 Installation and connection

The reactive power control relay RM 2112 and RM 2106 respectively can be connected in a number of different ways. The main connection methods are described below.

	Important information:
The control relay should be disconnected from the mains during installation.	

2.1 Installation

The reactive power control relay is installed from the front in a control panel space measuring 138 x 138 mm and is fixed in place using the mounting screws of the front panel.

As accessories (protection kit; see section 8) insulated fixing screws are available. These can be used to install the control relay into switchgear cabinets and cubicles of protective class II. Also a sealing ring is part of the protection kit, which must be used when installing the control relay in switchgear cabinets and cubicles of protection class IP 54.

The pre-assembled fixing clamps ensure speedy and secure assembly. The electrical connection is created by means of plug-in

connectors which are also included in the delivery.

2.2 Voltage connection

Reactive power control relay obtains its voltage supply via terminals "L" and "N" (see figure 2, item 'I').

A phase conductor is to be connected to terminal "L" and neutral conductor to terminal "N". For advanced connection variations see sections 2.7 to 2.10.

	Important information:
The reactive power control relay is designed for voltage supplies of up to 240 V AC.	
The connections for the supply voltage are to be fused externally with 4 A max.	

In the case of mains networks that do not facilitate voltage tapping in the 220 V AC to 240 V AC range (either phase/phase or phase/neutral), a voltage transformer must be used for the power supply for the control relay. (See section 2.9)

2.3 Current transformer connection

Outputs S1 and S2 of the current transformer are connected to terminals S1 and S2 (Figure 2, item 'j') of the control relay. To keep the load of the current transformer as low as possible, the feed lines should have a adequate cross section.

It is permissible for connector S1 or S2 of the current transformer to be grounded.

	Caution:
The nominal current in the current transformer path may not exceed 5 A.	

Note:

After connection it is necessary to remove the short-circuit jumper on the current transformer, if present.

2.4 "Meas" measuring voltage connection

This connection can be used to switch the control relay to a different measuring procedure for monitoring overcurrent (see section 2.8).

This terminal "**Meas**" (Figure 2, item 'k') is not used in the standard connection.

	Important information:
The nominal voltage between the "Meas" and "N" connectors may not exceed 240 V AC. The voltage between the "Meas" and "L" connectors may not exceed 420 V AC.	
If "Meas" is connected directly to a phase conductor, then this is to be secured externally with a maximum of 4 A.	

2.5 Switching contacts

The shared pole of all switching contacts (Figure 2, item 'm') is connected to terminal "L" of the voltage supply.

	Important information:
The outputs of the switching contacts do <u>not</u> have floating potential.	

When the switching contacts are switched, the same voltage is applied as is used to supply voltage to the control relay (connection "L").

The contactor relays of the capacitor stages are operated (supplied) via the switching contacts of the control relay.

2.6 Alarm contact

Switching contact 12 at RM 2112 (switching contact 6 at RM 2106) can be used either as a control output for a capacitor stage or as an alarm contact. The relevant selection is made in setup mode under -3-.

In the event of an alarm, switching contact 6 is closed.

It should be noted that, even when operating as an alarm contact, this switching contact continues to have potential binding to the supply voltage of the control relay. If a floating potential contact is required, use an additional contactor relay.

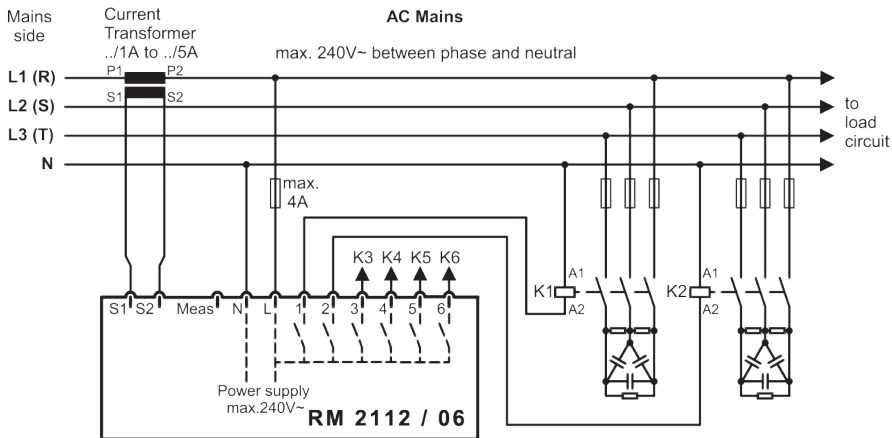

Figure 3 Single phase connection

2.7 Single phase connection

The connection diagram above shows the same connection as the one printed on the back of the control relay.

The voltage signal for power factor measurement is received in parallel with the voltage supply. The terminal "**Meas**" is not in use.

In this connection variant, only the 5th, 7th, 11th and 13th harmonics of the voltage are used to calculate the harmonic overcurrent in the capacitor.

This connection variant can be chosen if the above-mentioned harmonics are sufficient for monitoring overcurrent or if overcurrent monitoring has been completely switched off (setup code -2-). (see section 4.2)

Current transformer and terminal "**L**" should be attached to the same phase conductor: Either L1, L2 or L3.

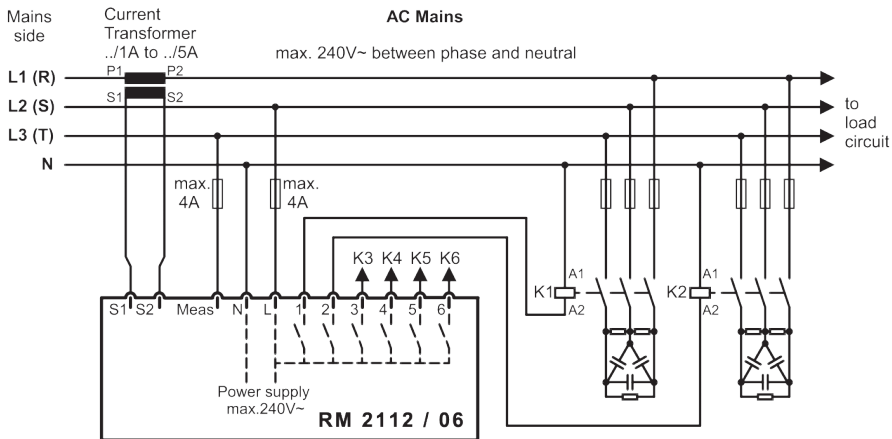

Figure 4 Extended connection

2.8 Extended connection

This type of connection offers a more precise measuring procedure for the overcurrent in the capacitor.

In this case, the terminal **"Meas"** is attached to another phase conductor of the AC mains network. The voltage signal for the internal measurements is tapped between terminal **"L"** and terminal **"Meas"**.

Because the voltage signal is recorded between

two phase conductors to which the capacitors are also connected, the dU/dt measuring procedure can be used for calculating the overcurrent.

This means that all frequencies up to the 31st harmonic are taken into account calculating harmonic overcurrent in the capacitor (see also section 4.2).

The total harmonic distortion factor of the voltage (thd) is also measured between the phase conductors in this type of connection.

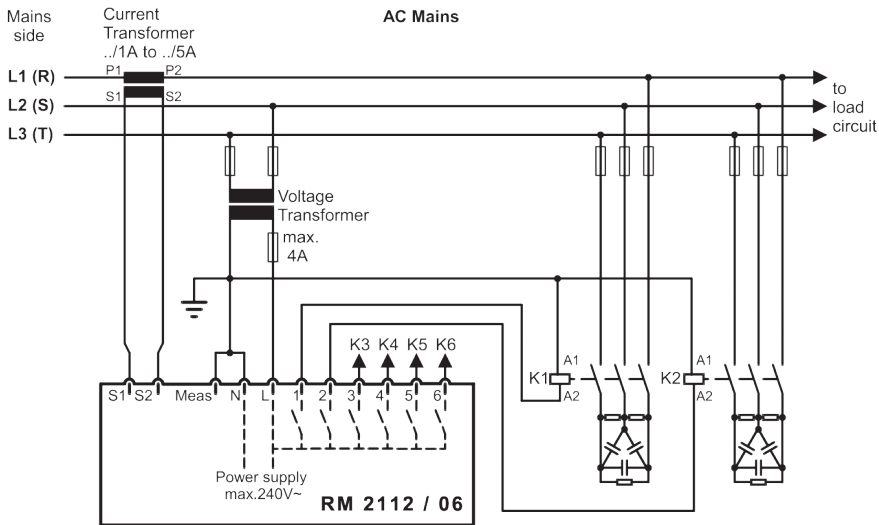

Figure 5 Connection with voltage transformer

2.9 Connection with voltage transformer

The connection diagram above shows how the control relay is connected together with a control transformer.



Important information:

The control voltage of the transformer may not exceed 240 V AC.

If the voltage signal is tapped by the control transformer between two phase conductors,

connection must be as shown in the diagram. The measuring procedure then is similar to that for the extended connection (see section 2.8).

If the control transformer taps the voltage signal between a phase conductor and neutral, the terminal **"Meas"** must remain unused.

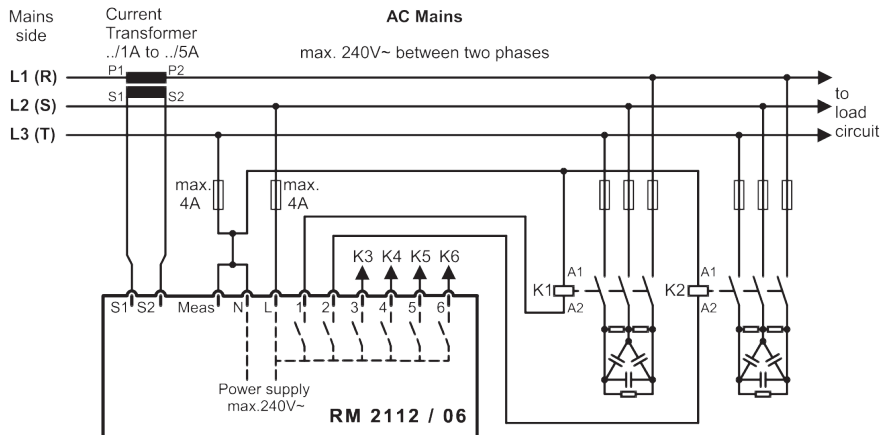

Figure 6 Connection in special cases

2.10 Connection in special cases

The type of connection shown above should be used if the voltage between the phase conductors does not exceed 240 V AC.

The following general principles apply:

If the terminal **"Meas"** remains unused, the voltage for terminals **"L"** and **"N"** must be connected to a phase conductor and to the neutral conductor.

If the terminal "**Meas**" is used, the voltage for terminals "**Meas**" and "**L**" must be connected each to a phase conductor.

For all types of connections (figure 3 to 6) it is also possible to connect the current transformer in phase conductors L2 or L3. In this case, the voltage connections to the phase conductors should be exchanged accordingly.

If the control relay operates with automatic response current recognition, connection errors would be reported.

If response current recognition is deactivated, then an error in the connection will lead to functional errors during subsequent operation.

3 Start-up

After installation has been carried out as described in section 2, the control relay can be started.

	Important information:
Make sure that the connector terminals of the control relay are no longer accessible (e.g. by means of a locked door or a cover hood).	

3.1 Initial start-up

During initial start-up the control relay attempts to determine the type of connection and the size of the stages. After about 5 seconds, "----" appears on the display (figure 1, item 'c'). The stages are switched on and off in succession. This can take up to 15 minutes.

	Important:
If the control relay does not behave as described above, the device should be switched off and the installation should be checked.	

It may be that the device has already been used and behaves as described in section 3.2.

If the measuring process is not complete after 15 minutes, then an error has probably occurred.

	Important information:
The device should always be switched off before carrying out wiring or installation activities.	

(For help in troubleshooting see section 6).

Note:

The control relay needs to be connected to at least one capacitor stage to switch in order to determine the type of connection.

Make sure that both the control circuit and at least one capacitor stage are fully functional.

It is also possible to abort the measuring procedure by switching off the automatic connection and response current identification. This takes place in setup mode -4- and simultaneously requires the manual programming of the stage parameters (see section 4.4).

After measurement the control relay indicates the results it has determined on the display (c).

Flashing messages that begin with **E** (e.g. **E2**), indicate an error. Message "**I=0**" also indicates an error after initial start-up.

In such cases the entire control system is to be switched off and the error must be eliminated. (For troubleshooting see section 6.)

In some circumstances the control relay displays the message "**A2**" after identification of the connection type. This means that there are deviations from the types of connection shown that do not restrict the control process.

This message is acknowledged automatically after about 30 seconds or can be acknowledged by pressing any key.

The control relay always displays "**A1**" after identification of the connection type. A stage indicator (a) also flashes. The value displayed alternately with "**A1**" in the display is the determined value for the indicated stage (switching contact).

This message is acknowledged automatically for each stage after about 15 seconds or can be acknowledged earlier by pressing any key.

When all messages have been acknowledged, the control relay begins the automatic regulating process. The current power factor appears on the display.

If the power factor displayed does not correspond to the actual power factor, the identification of the connection must be repeated. This is activated by pressing the "**Select**" and "**Voltage THD**" keys simultaneously for at least 3 seconds (check system).

3.2 Subsequent start-up

The control relay begins with its normal regulatory program immediately after a power failure.

If the "**Select**" and "**Voltage THD**" keys are pressed simultaneously for at least 3 seconds (check system), then the control relay carries out connection identification again. It then behaves in the same way as in the initial start-up (see section 3.1).

This requires that automatic connection identification should be activated. (setup mode -4-; see section 4.4)

The programmed control parameters are stored in a non-volatile memory and can be altered as necessary. (see chapter 4)

3.3 Maintenance

With maintenance of the power factor correction system, also the function of the control relay should be checked.

The control relay may be cleaned only with a dry cloth.



Important information:

The control relay should be disconnected from the mains while cleaning the back of the control relay.

4 Control relay setup

A wide range of setting options are provided to enable the reactive power control relay to be used in the widest possible way. To simplify matters the control relay is set to standard values in the factory (see table 1 below).

This means that the user mostly only needs to change the target power factor.

The setup mode can be reached from any of the control relay's operating modes.

Setup code	Significance	Standard values	Setting range
-1-	Target power factor	ind 1.00	From inductive 0.85 to 0.99 and from inductive 0.85 to 1.00 in steps of 0.01
-2-	Maximum harmonic over-current until the alarm is activated	1.30	From 1.05 times to 1.95 times the fundamental wave current or OFF in steps of 0.05
-3-	-Alarm output on contact 6 and contact 12 respectively -switch on or off alarm E5	OFF no alarm E5	OFF or On with or without alarm E5 (see section 4.3)
-4-	Automatic determination of response current	On	OFF or On

Table 1 Programmable values

Setup code	Significance	Standard values	Setting range
-5-	Manual setting of response current	2.00	from 0.02 to 2 in steps of 0.01
-6-	Relative value of the stage	1.0 for each switch output	Optional for each switch output the value 0 to 16 in steps of 1.0
-7-	Service	---	Measuring (only the fundamental frequency components): - Active current - Reactive current - Apparent current

Table 1 Programmable values

The procedure for checking or reprogramming the setting values is as follows:



- Press the **"Select"**(i) key to switch to setup mode (approx. 6 seconds) until the **"Setup Mode"** LED (f) lights up. "-1-" then appears on the display. This number (setup code) shows which variable is displayed and/or changed (see Table 1).
- The current setting alternates with the setup code on the display.
- By pressing **"Voltage THD"** key (h) it is possible to switch to the next highest setting value. The highest setting value is followed by the lowest setting value again.
- Pressing the **"Select"** key briefly switches to the next setup code (see Table 1). The setting value displayed can also be changed as described above.
- The control relay returns to automatic regulatory mode if the **"Select"** key is held down (approx. 3 seconds).

Note:
During "setup mode", no controlling activities are carried out by the control relay.

If no key is pressed for about 15 minutes, setup mode is quit automatically.

4.1 Target power factor setting -1-

The required target power factor can be set between 1.00 and ind. 0.85 in steps of 0.01.

This for example results in the following control characteristic for a target power factor of 1.00:

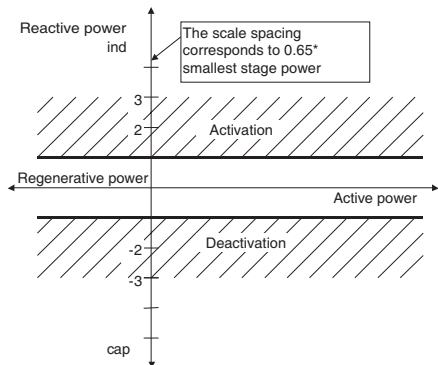

Figure 7 Target power factor 1.00

In this setting the control relay attempts to minimize reactive power irrespective of active power.

The control relay creates a tolerance band (or control band) around its target (in this case the target is to permit no reactive power). If the operating point is within the control band, then the control relay will not carry out any further switching.

For a target power factor of 1.00 this means that the permitted reactive power may not exceed 0.65 times the lowest capacitor stage.

If, on the other hand, the work point is outside of the control band, the control relay will attempt to reach the control band with the smallest possible number of switchings by means of specific activation and deactivation procedures.

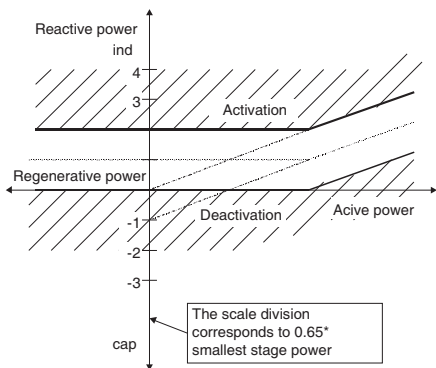

Figure 8 Target power factor 0.92

In addition to the target power factor setting 1.00, the control relay can also be set to a target power factor between 0.85 and 0.99. A distinction is made here between two different control bands. The control bands are distinguished by a large or small zero preceding the decimal point in the target power factor input.

The type of control band shown in figure 8 can be achieved by means of a large zero preceding the decimal point of the target power factor setting.

The target power factor forms the upper limit of the control band. The control relay always attempts to obtain a better power factor.

However, the control band levels off at low values of active power in order to avoid overcompensation.

For regenerative power (active power supplied to the mains) the control band stays leveled off for regenerative power.

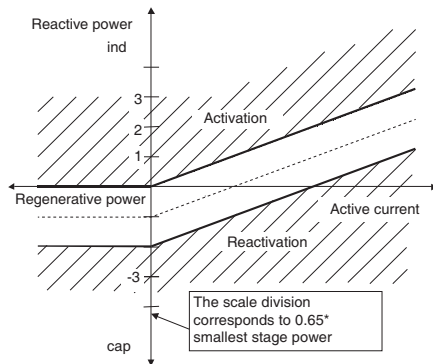

Figure 9 Target power factor 0.92

If generators are active in mains parallel mode, even small amounts of inductive reactive powers are unwanted in the mode of regenerative power.

In such cases the target power factor should be set with a small zero preceding the decimal point (see Figure 9).

The target power factor always forms the upper limit of the control band. However, a capacitive power factor in this case is preferred to even small amounts of inductive reactive power. So the control band is completely within the capacitive range for the mode of regenerative power.

4.2 Overcurrent switch off -2-

The control relay is capable of calculating the ratio between the rms current and the fundamental wave current (50 - 60 Hz) in the capacitor. This is achieved using the curve of the voltage signal.

If the set value of this ratio is exceeded for at least one minute due to harmonic oscillations and resulting resonance-related amplifications, then the control relay switches off all activated stages. An alarm signal is emitted at the same time.

After the overcurrent falls below the limiting value, the control relay begins to activate the stages again after waiting about 5 minutes.

Note:

This function should be set to OFF when choked capacitor stages are used.

4.3 Switching contact as alarm contact -3-

Contact 6 of the RM 2106 device or contact 12 of the RM 2112 device can be used to issue alarm signals.

If this menu item is set to **On**, then every alarm displayed by the alarm LED will also cause contact 6 or 12 to close.

	Important information:
All contact outputs don't have floating potential. If a floating potential contact is required, use an additional contactor relay.	

Historical alarms (alarms that are not pending at present) are not reported at the alarm contact.

In addition, at setup code -3- the alarm „*Target power factor not reached*“ **E5** can be permitted or suppressed. If the **ind** LED lights up the alarm is permitted. Otherwise the alarm is suppressed.

4.4 Automatic response current identification -4-

If set to **On** the control relay operates with the response current determined at initial start-up and the values determined for the switch outputs. These values can be read under points -5- and -6- .

If set to **Off** the response current (setup code -5-) and the value of the switch outputs (-6-) must be programmed manually.

This setting is to be selected if the low voltage network is fed by several transformers switched in parallel.

	Important:
If "OFF" is set, connection must be as shown in connection diagrams 3, 4, 5 or 6. Deviations are not signalled and are not corrected automatically.	

4.5 Response current -5-

The response current describes the width of the control band (see figures 7 to 9). The greater the value, the broader the control band.

When automatic response current identification is switched on (-4-), the response current is adapted to the connected power factor correction system to optimum effect. The response current determined can be read under setup code -5- but cannot be altered.

When automatic response current identification is switched off (-4-), the response current can be set between 0.02 and 2 A in steps of 0.01 A.

The correct setting for 400 V AC mains voltage and current transformer with 5 A AC secondary voltage can be found in Table 2.

For other mains currents or current transformers with unlisted primary or secondary current, the response current can be calculated according to the following formula:

$$I_A = 0.65 \cdot \frac{Q \cdot 400V \cdot k_u}{U^2 \cdot \sqrt{3} \cdot k_i} \approx 150V \cdot \frac{Q \cdot k_u}{U^2 \cdot k_i}$$

- I_A = Response current to be set in A
- Q = Capacitor **stage rating of the lowest stage** in var (not the overall power of the system)
- U = Mains voltage in V (phase to phase)
- k_i = Current transformer ratio (primary/secondary current)
- k_u = Voltage transformer ratio (primary/secondary voltage) (if any)

Response current setting 400 V AC mains voltage														
Current transformer A/A	Step size (= Rating of smallest stage kvar)													
	2.5	5	6.25	7.5	10	12.5	15	20	25	30	40	50	60	100
30/5	0.40	0.80	0.98	1.20	1.60									
40/5	0.30	0.60	0.74	0.90	1.20	1.50								
50/5	0.24	0.48	0.59	0.72	0.96	1.20	1.44							
60/5	0.20	0.40	0.49	0.60	0.80	1.00	1.20	1.60						
75/5	0.16	0.32	0.39	0.48	0.64	0.80	0.96	1.28	1.60	1.92				
100/5	0.12	0.24	0.30	0.36	0.48	0.60	0.72	0.96	1.20	1.44	1.92			
150/5	0.08	0.16	0.20	0.24	0.32	0.40	0.48	0.64	0.80	0.96	1.28	1.60	1.92	
200/5	0.06	0.12	0.15	0.18	0.24	0.30	0.36	0.48	0.60	0.72	0.96	1.20	1.44	
250/5	0.05	0.10	0.12	0.14	0.19	0.24	0.29	0.38	0.48	0.58	0.77	0.96	1.15	1.92
300/5	0.04	0.08	0.10	0.12	0.16	0.20	0.24	0.32	0.40	0.48	0.64	0.80	0.96	1.60
400/5	0.03	0.06	0.08	0.09	0.12	0.15	0.18	0.24	0.30	0.36	0.48	0.60	0.72	1.20
500/5	0.02	0.05	0.06	0.07	0.10	0.12	0.14	0.19	0.24	0.29	0.38	0.48	0.58	0.96
600/5		0.04	0.05	0.06	0.08	0.10	0.12	0.16	0.20	0.24	0.32	0.40	0.48	0.80
750/5		0.03	0.04	0.05	0.06	0.08	0.10	0.13	0.16	0.19	0.26	0.32	0.38	0.64
1000/5		0.02	0.03	0.04	0.05	0.06	0.07	0.10	0.12	0.14	0.19	0.24	0.29	0.48
1500/5			0.02	0.02	0.03	0.04	0.05	0.06	0.08	0.10	0.13	0.16	0.19	0.32
2000/5					0.02	0.03	0.04	0.05	0.06	0.07	0.10	0.12	0.14	0.24
2500/5						0.02	0.03	0.04	0.05	0.06	0.08	0.10	0.12	0.19
3000/5							0.02	0.03	0.04	0.05	0.06	0.08	0.10	0.16
4000/5								0.02	0.03	0.04	0.05	0.06	0.07	0.12
5000/5									0.02	0.03	0.04	0.05	0.06	0.10
6000/5										0.02	0.03	0.04	0.05	0.08

Table 2 Response current setting with 400 V AC mains voltage

If the step size, current transformer or nominal voltage of the power factor correction system do not match the values in the table, then the formula 1 on page 28 must be used to calculate the response current.

4.6 Relative value of the switch outputs -6-

These values refer to the relative stage ratings.

Example:

A system has the following stages:

Stage rating	=>	Relative value
6.2 kvar	=>	1.0
6.2 kvar	=>	1.0
12.5 kvar	=>	2.0
25 kvar	=>	4.0
25 kvar	=>	4.0
0 kvar	=>	0.0

Note:

To assure correct operation of the reactive VA control system the following conditions must be taken into account when choosing stage ratings: If all possible switching combinations are sorted according to reactive power (capacity), then the power difference between two consecutive combinations may not be more than 1.2 times the smallest stage power.

When automatic response current identification is switched on (-4-), the relative value is automatically determined by the control relay. This can be read under setup code -6- but not altered.

When automatic response current identification is switched off (-4-), the relative value of the switch outputs must be programmed manually.

The flashing LED in the stage display (a) indicate the switch output to which the relative value refers. Pressing the "Select" key (i) briefly allows you to skip to the next relative value.

The switch outputs with the lowest capacity are assigned relative value 1.0. The relative values for the bigger stages are calculated as follows:

Formula 2:

$$\text{Relative value} = \frac{\text{Stage power}}{\text{Smallest stage power}}$$

Free switch outputs are assigned relative value 0.0. Only whole numbers can be entered as factors.

4.7 Service -7-

The fundamental wave currents presently flowing in the current path (**j**) of the control relay and be displayed under this point.

The display for inductive or capacitive operating status (**b**) can be used to determine which current is displayed.

ind. and cap. off =>	active current
ind. or cap. off =>	reactive current
ind. and cap. on =>	apparent current

5 Functioning and operation

The control relay runs completely automatically after it has been connected and started. The current power factor appears in the digital display (c). The ind and cap LEDs (b) show whether the network is loaded with capacitive or inductive reactive power.

At the same time, the stage indicator (a) shows the switched capacitor stages.

5.1 Automatic control mode

In automatic control mode the control relay constantly measures the current power factor in the network and compares this with the target power factor. If deviations are identified that are in excess of the tolerance range (control band), the required target power factor is restored by activating or deactivating specific capacitor stages within the control relay delay time and in accordance with the capacitor discharge time.

The control relay delay time is adapted to the size of the deviation. The greater the deviation, the shorter the reaction time. In contrast, the capacitor discharge time is fixed at one minute.

In addition, the control relay monitors the overcurrent in the capacitors and checks whether the connected capacitor power is sufficient for compensation. If automatic response current

identification is activated, the control relay also checks the power of the capacitors connected.

The control relay issues an alarm in the event of an error. (see section 6)

5.2 Displaying the total harmonic distortion factor

If the control relay is in automatic control relay mode and if no historical or current alarm is pending, then pressing the "**Voltage THD**" key (h) will display the current total harmonic distortion factor (thd) of the voltage in %.

5.3 Check System

Simultaneously pressing "**Voltage THD**" (h) and "**Select**" (i) displays the current relative value of stage 1. The value displayed alternately with "**A1**" in the display (see section 6.2.2). It is acknowledged automatically for each stage after about 15 seconds or can be acknowledged earlier by pressing any key.

Simultaneously pressing "**Voltage THD**" (h) and "**Select**" (i) for about 3 seconds brings the control relay into check system mode.

If automatic response current identification (setup code -4-) is activated, then the control relay behaves as described in section 3.1 „**Initial start-up**“.

Note:
The check system mode defines the present stage ratings as reference values for subsequent stage rating checking.
(see section 3)

5.4 Manual mode

Pressing **"Select"** (i) for more than 3 seconds switches the control relay to manual mode. The **"Manual Mode"** LED (g) lights up.

The **"Voltage THD"** key (h) can now be used to select a switching output. The flashing LED in the stage indicator (a) shows which switching output is presently selected.

After a waiting period of about 10 seconds the switching status of the selected switch output is inverted. After switching the control relay remains in manual mode.

To quit manual mode, press the **"Select"** key (i) for over 6 seconds until neither the **"Manual Mode"** LED (g) nor the **"Setup Mode"** LED (f) lights up.

Note:
No automatic switching activities are carried out in manual mode. Manual mode does not terminate automatically.

Alarm signals E4 and E5 are also generated in manual mode, but do not lead to any switching activities.

An exception to this is the alarm contact when alarm output is activated on contact 6 of the RM 2106 device or contact 12 of the RM 2112 device (setup code -3-).

6 Alarms and troubleshooting

The control relay has a number of ways of identifying connection errors and functional errors.

6.1 Connection errors

If automatic response current identification has been activated on the control relay (setup code -4-), the control relay can identify the following errors after "initial start-up" or "check system" procedure.

In all cases the connection of the power factor correction system and the wiring of the control relay are to be checked (see connection diagrams 3 to 6).

6.1.1 E3 - No capacitors

This error message appears when the control relay was able to measure a current, but was unable to detect a change in current when switching the capacitor stages.

This can have the following causes:

- control contacts (contactors) are not connected or are not working correctly
- the fuses of the capacitor stages have not been installed
- the current transformer is not located between power supply and loads

(including PFC) (see connection diagrams 3 to 6).

In this case the reactive power control system must be set out of operation and the error has to be eliminated.

The faulty power control system may not be operated under any circumstances in this condition.

6.1.2 E1 - Defect capacitor stages

Possible causes:

- individual capacitor stages only have 2-phase connections to the mains
- the defect capacitor stages do not draw a symmetrical current from the 3 phases

6.1.3 E2 - Incorrect connection

Possible causes:

- the entire power factor correction system or all capacitors have only been connected in 2-phase connections
- the "Meas" terminal is unused and 2 phase conductors are connected between terminal "N" and "L"
- the "Meas" terminal is connected to the neutral conductor
- the "L" terminal is connected to the neutral conductor

6.1.4 I = 0 - No current in current path

It was not possible to measure a current of more than 20 mA in the current path when capacitor stages were either activated or deactivated.

Possible causes:

- fault in the current transformer connection
- the current transformer is located in the wrong place
- the current transformer ratio is too high

6.2 Connection messages

In addition to the error messages, the control relay also displays the results of its automatic connection recognition. Messages A1 and A2 can be acknowledged by pressing any key or are automatically acknowledged after a waiting period of about 30 seconds.

6.2.1 A2 - Incorrect connection that can be corrected internally

The connection has not been made in accordance with connection diagrams 3 to 6. However, the problem has been recognised as a simple confusion in the phase conductors or in the connection of the current transformer. The control relay can continue to operate with this connection.

6.2.2 A1 - Relative value of the switch output

The value for the relevant switch output is displayed while message A1 appears on the display. Switch outputs at which little or no capacitor rating has been recognised are assigned switching sequence factor 0.0. The user should check whether the values displayed correspond to the connected capacitor stage. The connection must be checked if deviations are extreme. The switching sequence determined is also stored in the setup mode (-6-).

6.3 Alarms in automatic control operation

The "**Alarm**" LED (**e**) lights up for as long as an alarm is active. If alarm output was activated on contact 6 of the RM 2106 device or contact 12 of the RM 2112 device (setup code -3-), this contact also closes. If the alarm status has ended, the "**Alarm**" LED turns off and the alarm contact opens again if in use. The message continues to flash on the display. Pressing the "**Voltage THD**" key (**h**) enables the *cause of the alarm* to be read out and the alarm to be acknowledged during or after the alarm .

6.3.1 E4 - Harmonic overcurrent in the capacitor

The control relay issues this alarm if the programmed limiting value for the "harmonic overcurrent" (setup code -2-) is exceeded for more than 1 minute. All activated capacitor stages are deactivated.

After the overcurrent falls below the limiting value, the control relay begins to activate the stages again after waiting about 5 minutes. The maximum overcurrent factor ($I_{\text{eff}}/I_{50/60\text{Hz}}$) is recorded as the *cause of the alarm*.

6.3.2 E5 - Target power factor not reached

If the operating point of the control relay is above the control band (see section 4.1) and if all available capacitor stages have already been activated, the control relay issues error message E5 after a delay. The lowest measured power factor during the alarm is recorded as the *cause of the alarm*.

This alarm can be suppressed at setup code -3- (see section 4.3)

6.3.3 E1 - Defect capacitor stages

After initial start-up or "check system" procedure, the determined stage ratings are stored in a non-

volatile memory (only when automatic response current identification is active; setup code -4-).

If the control relay detects a drop in stage rating during operation of more than 20% or there is an extremely asymmetrical current in the three phases of a capacitor stage, it registers these stages as defect. The defect stages can be read out as the *cause of the alarm*.

Note:

This function only works if automatic response current identification is active.

6.3.4 U = 0 - No measuring voltage

This message indicates that the control relay with connected "Meas" terminal has been put into operation, however no voltage can be measured at this input at present.

It is not possible to read the *cause of the alarm*. Likewise this message can only be acknowledged by eliminating the error.

6.4 I = 0 - No measuring current

If the current in the current measurement path drops below 20 mA, the message "I=0" appears on the display.

The control relay deactivates a capacitor stage after about 3 seconds. If this does not result in a change in current, then the stages still active are also deactivated.

This signal does not activate an alarm.

6.5 Other errors

Situations may arise due to the connection or special operating conditions that cannot be identified by the control relay.

Table 3 below lists further sources of errors.

7 Trouble-Shooting

Pos.	Fault	Possible causes	Necessary action
1	Control relay not working; no displays on the front of the control relay	No or the wrong voltage has been applied to the control relay	Check that operating voltage applied to the control relay is at the right level
2	The control relay does not react to manual switching despite availability of power and functioning indicators	Delay time of about 10 seconds is not up	If the required stage flashes in the stage display (a) then wait until the stage switches
		Manual mode is not activated	Hold down „Select“ key until „Manual Mode“ LED (g) lights up
3	Stage indicator (a) lights up, however capacitor contactors are not switched on	Control circuit not connected correctly or no control voltage	Check the control circuit in accordance with the connection diagram; check fuse
		No zero conductor at contactors	
4	Control relay does not terminate the automatic measuring procedure	Unstable mains supply (strong power factor variation)	Wait for more stable mains conditions or enter the response current and switching sequence manually
5	One stage is continuously activated and deactivated in automatic control relay mode	Response current set too low	Set the response current correctly in accordance with Table 1 or Formula 1
		Strong load variation	

Table 3 Notes on troubleshooting

Pos.	Fault	Possible causes	Necessary action
6	No stage activation in automatic control relay mode despite inductive load	The response current has been programmed incorrectly	Set the response current correctly in accordance with Table 1 or Formula 1
		Response current not correctly identified despite automatic response current identification being set	Check the control circuit according to the connection diagram and repeat the check system procedure
		Another measuring device switched in parallel with the control relay current path	Current paths for different measuring devices should always be switched in series
		Step size of capacitor is too large	Introduce capacitors with smaller step size
7	„I=0“ flashes on the display	Current transformer line interrupted or short-circuited	Check current in current path using ammeter ($I_{\min} \geq 0.02 \text{ A}$)
8	Displayed power factor is less than target power factor, even though the control relay has activated all stages	Error in the control circuit	Check for the contactors to be energized
		Error in the capacitor current circuit	Check fuses and contacts of capacitor contactors as well as the power consumption of the various capacitor stages if necessary
		System too small	Add capacitors
9	Control relay does not switch off all stages at light load or standstill	Response current is set too high	Set the response current correctly according to Table 1 or Formula 1
		Control relay in manual mode	Press the „ Select “ key (i)

Table 3 Notes on troubleshooting

8 Technical Data

Mode of Connection:

As shown in connection diagrams 3 to 6

Operating Voltage:

Supply voltage	Absolute permissible threshold values
220 - 240 V AC	195 ... 264 V AC

Frequency:

50 Hz / 60 Hz (48 to 62 Hz)

Consumption of supply voltage:

Approx. 4 VA

Current path:

For current transformer: ... / 1 AAC to ... / 5 AAC

Permissible maximum current: 6 A~

Consumption in current path:

max. 0.5 VA at 5 A AC

Measuring voltage at terminal "Meas":

Maximum 264 V AC at terminal "N"

Control Contacts:

RM 2106: 6 switching contacts

RM 2112: 12 switching contacts

with potential binding to supply voltage (terminal „L“)

Loading Capacity of the control contacts:

per contact (max.) 2 A

(only ohmic or inductive load)

total contact current (max.) 4 A

total contact load (max.) 950 VA

No-voltage Trip

(Undervoltage monitoring):

With voltage drops under 170 V for more than 10 ms all capacitor stages connected are switched off. After voltage is restored the control relay switches the required stages on.

Zero current trip:

For a current loss of longer than 3 seconds all capacitor stages connected are switched off. After current is restored the control relay switches the required stages on.

Discharge time for the capacitors:

min. 1 min.

Controls:

Keypad with 2 keys

Indicator elements:

RM 2106: 12 LEDs

RM 2112: 18 LEDs

3 character digital display

Operating temperature range:

-25 °C to +60 °C

Housing:

Plastic, black
flame-retardant as per UL-94 V0

Mounting:

From the front panel using a screwdriver

Front panel dimensions:

144 x 144 mm (DIN 43 700)

Panel hole size:

138 x 138 mm (to DIN 43 700)

Installation depth:

40 mm

Weight:

approx. 0.8 kg

Installation position:

as required

Connections:

Terminal block
cable cross section max. 1.5 mm²

Protection class:

Terminal block	IP 20
Housing	IP 54

(when the sealing ring is used)

Design as per:

DIN EN 61010-1 (IEC 1010-1)
Protection Class II (when insulated mounting
screws are used)

EMC:

EMC Immunity	DIN 61000-6-2
EMC Emission	DIN 61000-6-3

Fuse:

External, max. 4 A specified

Accessories:

protection kit for protection class II/IP54
Art.No. 20-50014

Notes:

Power Capacitors

Reactive Power Control Relays

Power Factor Correction Systems

Modules

EMS Components

Measuring Instruments and Network Analysers

Power Quality

EMS ISO 50001



FRAKO Kondensatoren- und Anlagenbau GmbH

Tscheulinstraße 21a

D-79331 Teningen

Germany

Phone: +49 7641 453-0

Fax: +49 7641 453-535

sales@frako.com

www.frako.com